

# D16

SECTIONAL VALVE



 **walvoil**  
MOTION BY PEOPLE

TECHNICAL CATALOGUE



 **walvoil**  
MOTION BY PEOPLE

**3<sup>rd</sup> edition Jan.2024**

---

**Additional information**

*This catalogue shows the product in the most standard configurations.  
Please contact Sales Dpt. for more detailed information or special request.*

**WARNING!**

*All specifications of this catalogue refer to the standard product at this date.  
Walvoil, oriented to a continuous improvement, reserves the right to  
discontinue, modify or revise the specifications, without notice.*

**WALVOIL IS NOT RESPONSIBLE FOR ANY DAMAGE CAUSED BY AN  
INCORRECT USE OF THE PRODUCT.**



### Applications

The valve is available with manual, hydraulic remote, pneumatic, electrohydraulic and electropneumatic controls. Numerous configurations and solutions are possible. Working sections have auxiliary valves and a broad range of interchangeable spools. Special versions for LS variable pumps can be realised on request. Suitable for applications including Backhoe loaders, Wheel loaders, Backhoes, Compactor, Hook and Skip loaders, Drilling machines.

D16 has available:

Special inlet section with second pump managing system (Backhoe loaders).

Electric operated clamping valve (Backhoe loaders).

Special inlet with priority function for steering.

Special intermediate section for combination with D20 and D25.





QUICK REFERENCE GUIDE

GENERAL SPECIFICATION	D9	D3M	DVS10	D4	D6	D16	D12	DVS20	D20	D25	D40
Working sections number	1-12	1-12	1-12	1-12	1-12	1-12	1-12	1-12	1-12	1-12	1-10
<b>CIRCUIT</b>											
Parallel	•	•	•	•	•	•	•	•	•	•	•
Series	•	•	•	•	•	•	•		•	•	
Tandem	•	•	•	•	•	•		•	•		
Parallel circuit stroke (mm)	6	5	6	6	7	7	9,5	9,5	9,5	12	15
Series circuit stroke (mm)	6	5	6	6	5	7	6,5		6,5	8,5	
Float spool extra stroke (mm)	5	5	5	5,5	6	7	7	7	7	9,5	10
Spools pitch (mm)	31	38	35	40	46	46	56	56	64	75	91
<b>RATED FLOW</b>											
Max recommended flow rate (l/min)	35	55	45	80	100	150	180	250	250	380	700
Max recommended flow rate (GPM)	10	15	12	22	27	40	48	67	67	100	185
<b>RATED PRESSURE</b>											
Max working pressure (bar)*	315	350	350	350	315	350	350	250	350	350	350
Max working pressure (PSI)*	4500	5000	5000	5000	4500	5000	5000	4000	5000	5000	5000

NOTE (\*): Intermittent pressure at max. 1 million cycles with specific internal testing.

OPTION CHART	D9	D3M	DVS10	D4	D6	D16	D12	DVS20	D20	D25	D40
Direct acting pressure relief valve	•	•	•	•							
Pilot operated pressure relief valve		•		•	•	•	•	•	•	•	•
2 stage pilot operated relief valve		•		•	•	•	•		•	•	•
Externally piloted valve	•	•	•	•	•	•	•		•	•	•
Solenoid dump valve (12 Vdc)	•	•	•	•	•	•	•				
Solenoid dump valve (24 Vdc)	•	•	•	•	•	•	•				
Main anticavitation check valve		•		•	•	•	•	•	•	•	•
Clamping valve		•	•	•							
<b>SPOOL ACTUATION</b>											
Manual control	•	•	•	•	•	•	•	•	•	•	•
Without lever	•	•	•	•	•	•	•	•	•	•	•
90° joystick control		•	•	•	•	•					
Hydraulic control	•	•	•	•	•	•	•	•	•	•	•
Direct electric control (12-24 Vdc)		•		•							
<b>SPOOL RETURN ACTION</b>											
Spring return	•	•	•	•	•	•	•	•	•	•	•
Detent in A - in B - in A/B	•	•	•	•	•	•	•	•	•	•	•
Detent in 4 <sup>th</sup> position	•	•	•	•	•	•	•	•	•	•	•
Arrangement for dual control	•	•		•	•	•	•		•		
Hydraulic load limit	•	•		•	•	•					
Pneumatic control ON - OFF		•	•	•	•	•	•	•	•		
Proportional pneumatic control		•	•	•	•	•	•	•	•		
Electrical load limit	•	•		•	•	•					
Electrohydraulic control ON-OFF (12-24 Vdc)		•	•	•	•	•	•	•	•		
Electrohydraulic control PROP. (12-24 Vdc)		•	•	•	•	•	•	•	•		
Electropneumatic control (12-24 Vdc)		•	•	•	•	•	•		•		
<b>AUXILIARY VALVES</b>											
Antishock valve	•	•	•	•	•	•	•	•	•	•	•
Anticavitation valve	•	•	•	•	•	•	•	•	•	•	•
Combined valve	•	•	•		•	•	•		•	•	•
Pilot combined valve						•		•	•	•	•



**GENERAL INDEX**

<b>4</b>	<b>General specifications</b> Standard working conditions Fluid options
<b>5</b>	<b>Order example</b> Standard thread Thread codes Tie-rod kit classification Painting
<b>7</b>	<b>Dimensions</b>
<b>8</b>	<b>Typical curves</b> Pressure drop (P - T) Pressure drop (P - A/B) Pressure drop (A/B - T) Direct relief valve curve Combined valve curve Antishock valve curve Anticavitation check valve curve
<b>10</b>	<b>Inlet Section</b> Order example Inlet side classification Valve identification Valve arrangement Inlet position and available thread type
<b>13</b>	<b>Working section</b> Order example Spool identification Spool actuation classification for manual control Spool actuation classification for hydraulic control Spool return action classification - Spring load values Work section identification Auxiliary valves identification
<b>27</b>	<b>Intermediate inlet section</b> Order example Intermediate inlet section classification Valve identification on intermediate inlet section Valve arrangement on intermediate inlet section Inlet position and available thread type
<b>30</b>	<b>Intermediate outlet section</b> Order example Intermediate outlet section classification Inlet position and available thread type (for BF intermediate) Inlet position and available thread type (for BG intermediate)
<b>33</b>	<b>Outlet section (version 1 outlet)</b> Order example
<b>33</b>	<b>Outlet section (HPCO version outlet)</b> Order example - HPCO version outlet Outlet with single tank classification Outlet with two tanks classification Carry-over connection (HPCO)
<b>37</b>	<b>D16 Spare parts list</b> Gasket kits
<b>41</b>	<b>Installation and maintenance</b>
<b>43</b>	<b>General conditions and patents</b>



**GENERAL SPECIFICATIONS**

**Standard working conditions**

Description	Value
Ambient operating temperature range	-40°C / +60°C
Kinematic viscosity range	10 ÷ 300 cSt
Max contamination level	9 (NAS 1638) - 20/18/15 (ISO 4406:1999)
Recommended filtration level	b10 > 75 (ISO 16889:2008)
Internal filter (on electroproportional valves pilot line)	30 µm

All information and diagrams in this catalogue refer to a mineral base oil VG46 at 50°C temperature (32 cSt kinematic viscosity)

**Fluid options**

Types of fluid (according to ISO 6743/4) Oil and Solutions	Temperature (°C)		Compatible gasket
	min	max	
Mineral Oil HL, HM (or HLP acc. to DIN 51524)	-25	+80	NBR
Oil in water emulsions HFA	+5	+55	NBR
Water in oil emulsions HFB	+5	+55	NBR
Polyglycol-based aqueous solution HFC	-10	+60	NBR

For special applications and different fluids, please call our Technical Department.



**ORDER EXAMPLE**

**D16/1: IR 009 150 A G05 W001A H001 F001A RP G05 01 PA 100 05 PB TJ A G06**

**TYPE:**

**D16:** product type  
**/1:** working section number

**1) INLET ARRANGEMENT: pag. 10**

**IR 009** inlet side and valve type  
**150** setting (bar)  
**A G05** inlet position and available thread type

**2) WORK SECTION ARRANGEMENT: pag. 13**

**W001A** spool type  
**H001** spool actuation type  
**F001A** spool return action type  
**RP G05** type and thread section  
**01 PA 100** auxiliary valve (port A)  
**05 PB** auxiliary valve (port B)

**3) OUTLET ARRANGEMENT: pag. 33**

**TJ** outlet type  
**A G06** outlet position and available thread type

Ordering row 2 must be repeated for every work section

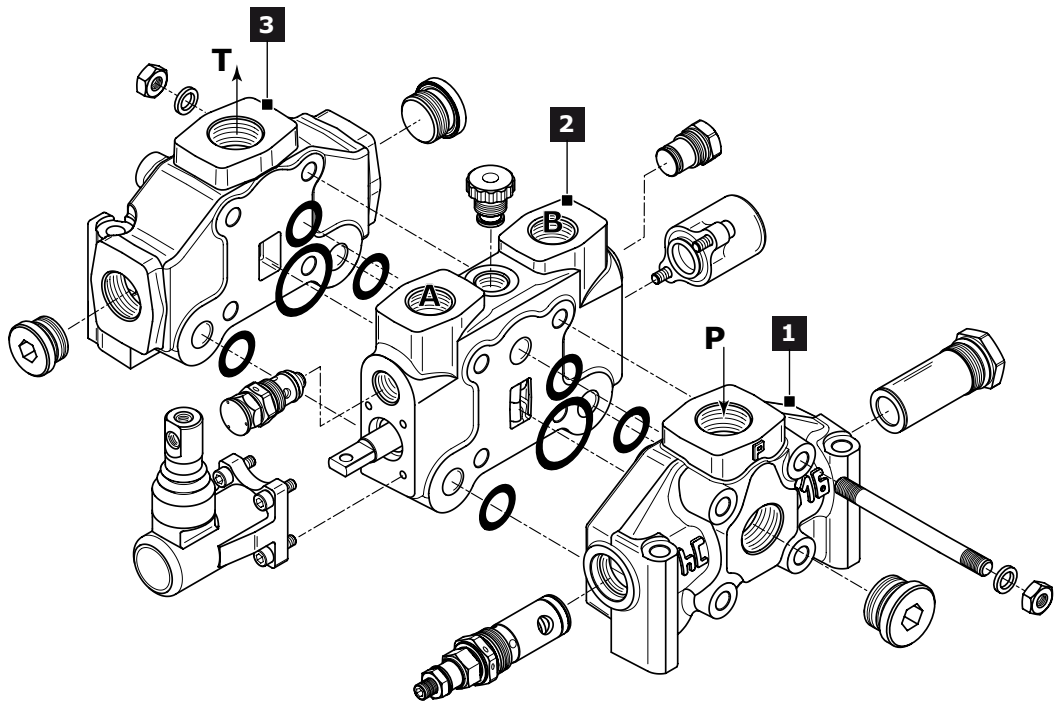

The connection ports size is indicated by an ordering code common for all Walvoil products. Following table shows all available connections; for ordering code refer to table on page 42.

Ports	BSP (ISO - 228)	Code	UN-UNF (ISO - 725)	Code
<b>Inlet Port (P)</b>	G 3/4	<b>G05</b>	1"1/16 - 12 UNF	<b>U05</b>
<b>Ports (A - B)</b>	G 3/4	<b>G05</b>	1"1/16 - 12 UNF	<b>U05</b>
<b>Outlet (T) - Carry over (HPCO)</b>	G 1	<b>G06</b>	1"5/16 - 12 UNF	<b>U06</b>
<b>Hydraulic Pilot</b>	G 1/4	<b>G02</b>	9/16" - 18 UNF	<b>U02</b>
<b>Pneumatic Pilot</b>	G 1/8	-	NPTF 1/8-27	-



**Tie-rod kit classification (appendix "A")**

Tie rod kit allows the correct assembly of sectional valves. Tie rod's length depends on the number of sections; each valve is assembled with tie rod kits including a tie rod, two nuts and two washers. D16 requires 4 tie-rod kits.

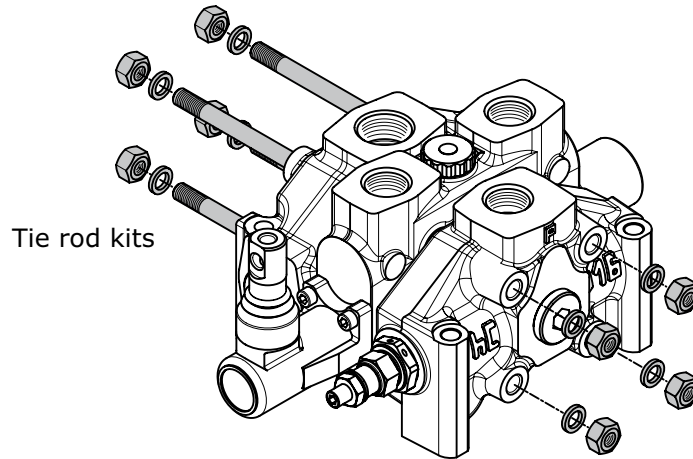

Tie rod kit	Order Code	Lenght (mm)	Clamping Torque (Nm)	Quantity
D16/1	300145001	200		
D16/2	300145002	246		
D16/3	300145003	292		
D16/4	300145004	338		
D16/5	300145005	384		
D16/6	300145006	430		
D16/7	300145007	476	50	4
D16/8	300145008	522		
D16/9	300145009	568		
D16/10	300145010	614		
D16/11	300145011	660		
D16/12	300145012	706		

**Painting**

On request, all Walvoil valves can be delivered painted (RAL 9005 black primer).

**Order example of D16/1 painted:**

D16/1  
IR 009 150 A G05  
W001A H001 F001A RP G05 01 PA 100 05 PB  
TJ A G06

**P006/1 N10**

The painting is indicated with the following value:

**P006 - /1 - N10**

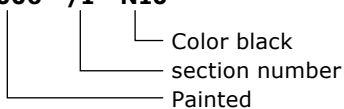





**DIMENSIONS**

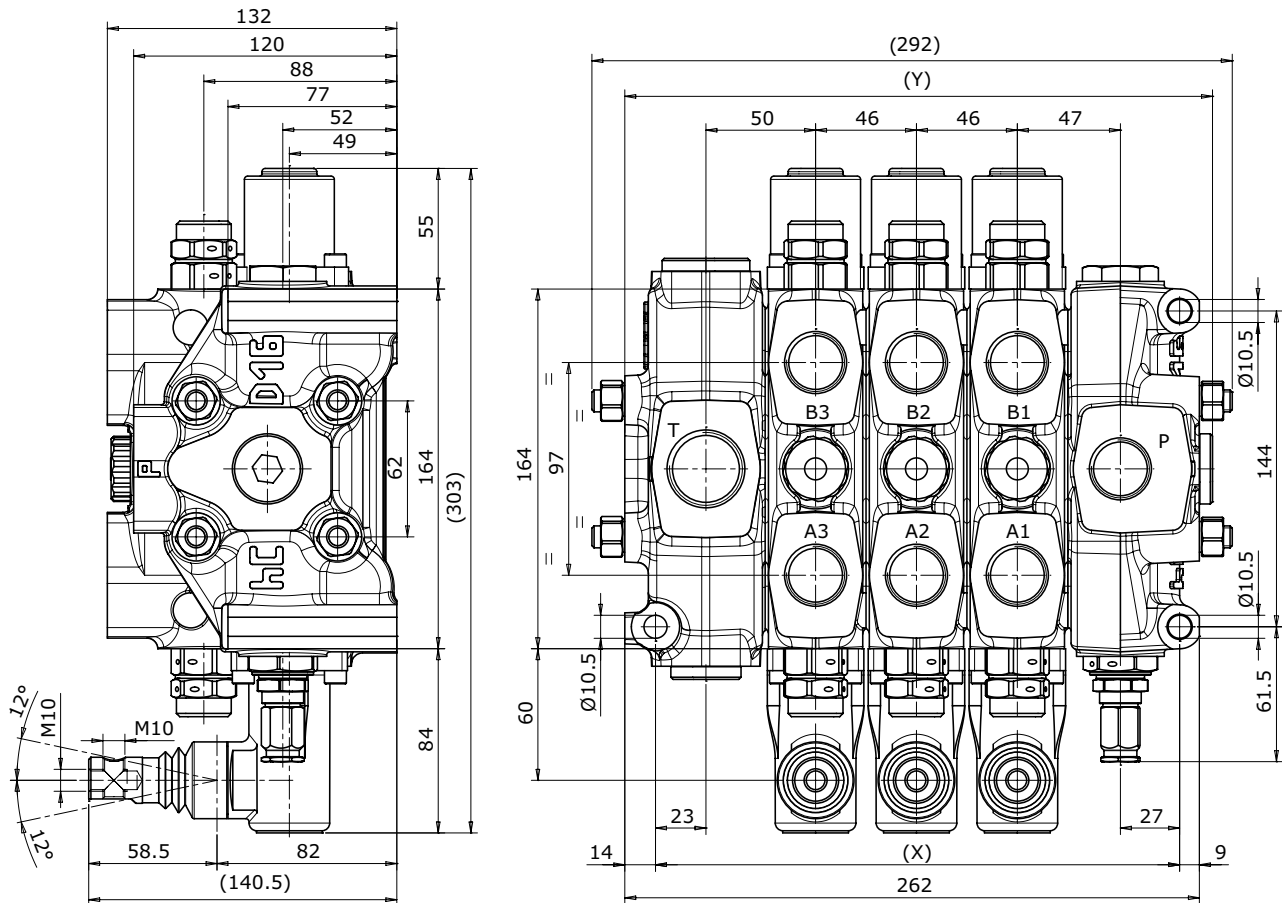

TYPE	/1	/2	/3	/4	/5	/6	/7	/8	/9	/10	/11	/12
<b>X (mm)</b>	147	193	239	285	331	377	423	469	515	561	607	653
<b>Y (mm)</b>	170	216	262	308	354	400	446	492	538	584	630	676
<b>Weights (kg)</b>	19,1	24,1	29,2	34,4	39,5	44,5	49,6	54,7	59,8	64	70	75,1



TYPICAL CURVES

Indicated values have been tested with standard sectional valve and W001A spool.

Pressure drop (P - T)

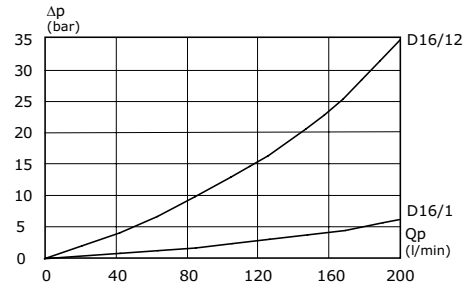
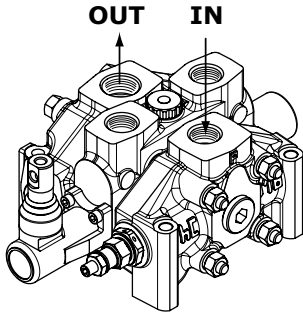

Pressure drop (P - A/B)

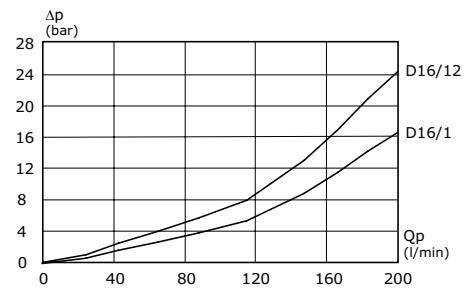
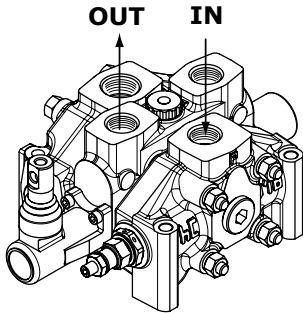

Pressure drop (A/B - T)

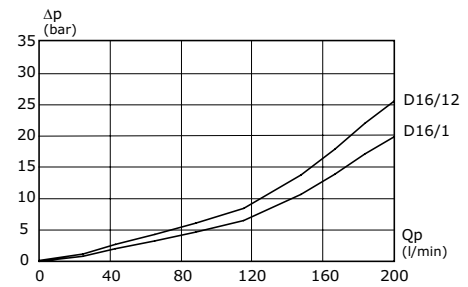
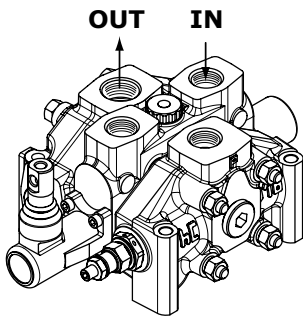

Pilot operated relief valve curve

Setting ranges	
type	pressure (bar)
A	0 - 40
B	41 - 180
C	181 - 250
D	251 - 350

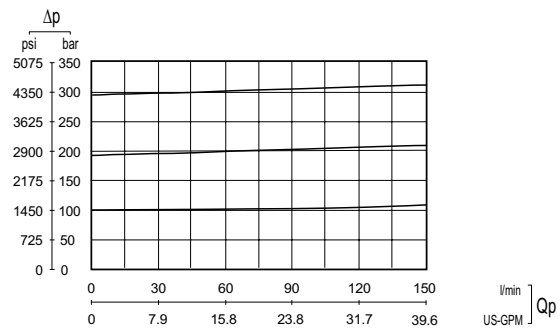



**TYPICAL CURVES**

Indicated values have been tested with standard sectional valve and W001A spool.

**Antishock valve curve**

type	Setting ranges	
	pressure (bar)	
	at full flow	at min. flow
A	70 - 150	70-A / 120-A
B	151 - 230	121-A / 200-A
C	231 - 280	201-A / 250-A
D	281 - 350	251-A / 350-A

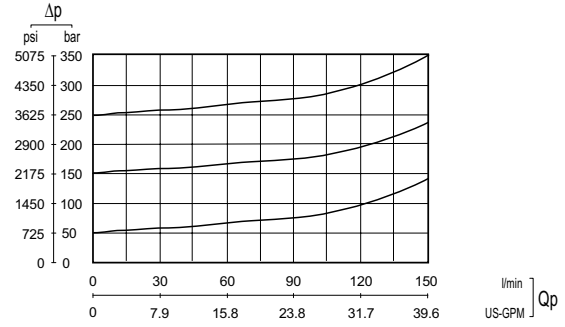

**Combined valve curve**

type	Setting ranges	
	pressure (bar)	
	at full flow	at min. flow
A	30 - 95	30-A / 65-A
B	96 - 150	66-A / 120-A
C	151 - 260	121-A / 230-A
D	261 - 350	231-A / 350-A

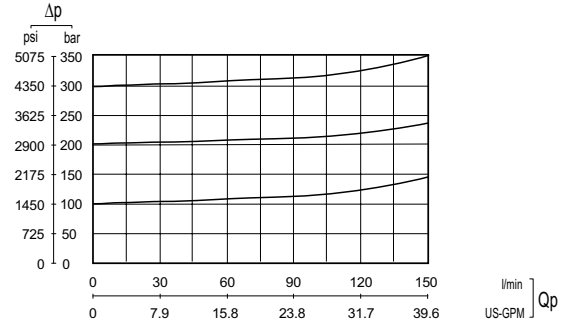

**Main anticavitation check valve curve**

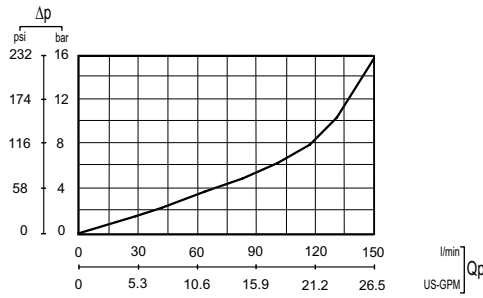

**Anticavitation check valve curve**

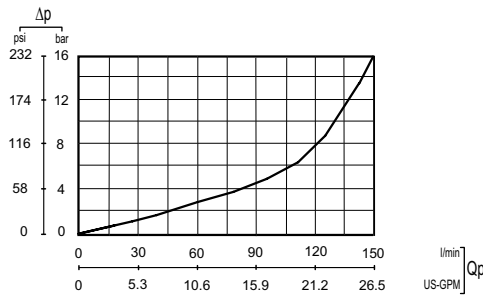



INLET SECTION

Order example

IR	009	150	A G05
----	-----	-----	-------

1. **IR** inlet side classification \_\_\_\_\_
- 009** valve arrangement \_\_\_\_\_
- 150** setting (bar) \_\_\_\_\_
2. **A G05** inlet position and available thread type \_\_\_\_\_

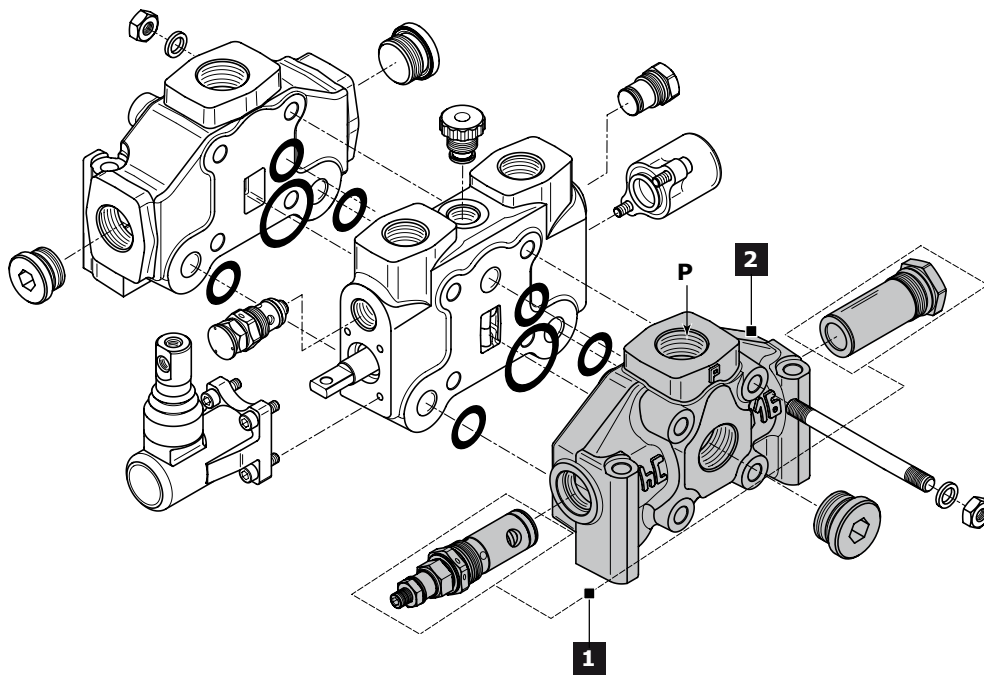

Rif.	Code	Description	Page
-	<b>IR</b>	Sectional valve with right inlet section	<b>11</b>
	<b>IL</b>	Sectional valve with left inlet section	
1	<b>009</b>	Pilot operated pressure relief valve	<b>12</b>
	<b>010</b>	Pilot operated pressure relief valve and Main anticavitation check valve	
	<b>012</b>	Pilot operated pressure relief valve and Solenoid dump valve 12 Vdc	
	<b>013</b>	Pilot operated pressure relief valve and Solenoid dump valve 24 Vdc	
	<b>019</b>	Without valves	
	<b>020</b>	Main anticavitation check valve	
2	<b>A G05</b>	Upper inlet (thread G 3/4)	
	<b>C G05</b>	Central side inlet (thread G 3/4)	
	<b>A U05</b>	Upper inlet (thread 1"1/16-12 UNF)	
	<b>C U05</b>	Central side inlet (thread 1"1/16-12 UNF)	

**NOTE:** when ordering a relief valve it is necessary to specify factory setting (example 150).



**Inlet side classifications**

	Sectional valve with <b>right inlet</b> section	Sectional valve with <b>right inlet</b> section
<b>IR</b>		

**Valve identification**

type	schema	layout	description	type	schema	layout	description
<b>2</b>			Pilot operated pressure relief valve	<b>6</b>			Externally piloted valve
<b>3</b>			Relief valve plugged	<b>7</b>			Solenoid dump valve 12 Vdc
<b>4</b>			Main anticavitation check valve	<b>8</b>			Solenoid dump valve 24 Vdc
<b>5</b>			2 stage pilot operated relief valve	<b>11</b>			Plug with pressure-gauge connection

**Valve arrangement**

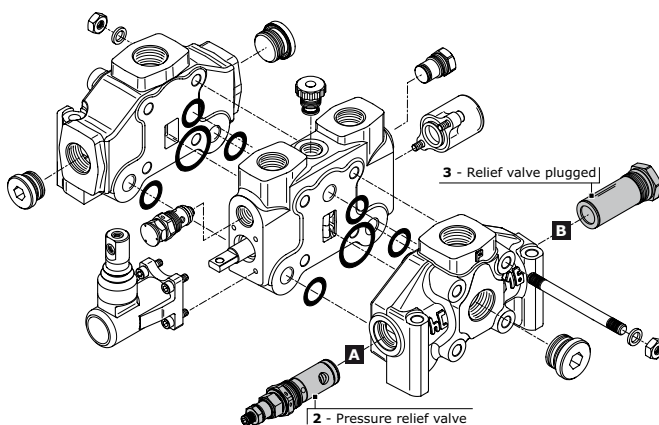

**Combination valve example: 009 = 2A - 3B**

















- 009** Combination valve
- 2A** Pressure relief valve in port A
- 3B** Relief valve plugged in port B

**The code identifies:**  
with a number, the type of valve; with a letter its position on the inlet section.

- (A) = spool action side
- (B) = spool return action side

**NOTE:** when ordering a main relief valve it is necessary to specify setting



VALVE COMBINATION INLET SECTION		Valve type on port B								
										
		2	3	4	5	6	7	8	11	
Valve type on port A		2	009	010		011	012	013	016	
		3	018	019	020	021	022	023	024	027
		4	029	030		031	032	033	034	037
		5		038						
		6	047	048						
		7	054	055						
		8	061	062						
	11	085								

NOTE: Valve combinations 021, and 038 requires double setting (see example).

Order example for inlet section: IR **038 200\*280** A G05

038  
200\*380

valve combination \_\_\_\_\_  
double range setting (bar) \_\_\_\_\_

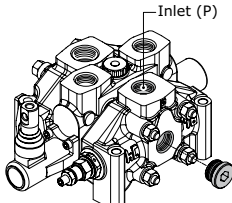
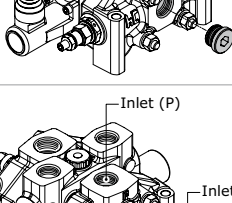
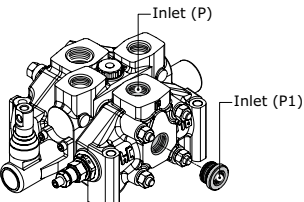
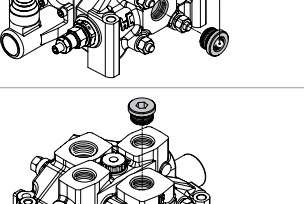
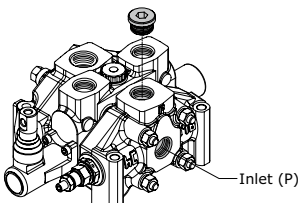
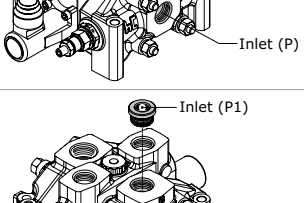
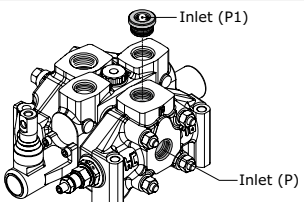
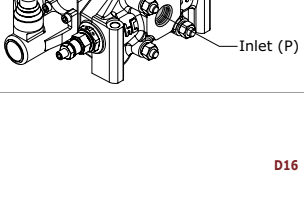
Inlet combination and thread available		
A G05		Upper inlet (thread G 3/4)
A U05		Upper inlet (thread 1"1/16-12 UNF)
B G05		Upper inlet P1 with pressure-gauge connection G1/4 (thread G 3/4)
B U05		Upper inlet P1 with pressure-gauge connection G1/4 (thread 1"1/16-12 UNF)
C G05		Central side inlet (thread G 3/4)
C U05		Central side inlet (thread 1"1/16-12 UNF)
D G05		Central side inlet P1 with pressure-gauge connection G1/4 (thread G 3/4)
D U05		Central side inlet P1 with pressure-gauge connection G1/4 (thread 1"1/16-12 UNF)



**WORKING SECTION**

Order example:

	W001A	H001	F001A	RP G05	01 PA 100	05 PB
1. <b>W001A</b>	spool type					
2. <b>H001</b>	spool actuation type					
3. <b>F001A</b>	spool return action type					
4. <b>RP G05</b>	section and thread type					
5. <b>01 PA 100</b>	auxiliary valve (port A - handle side)					
6. <b>05 PB</b>	auxiliary valve (port B - cap side)					

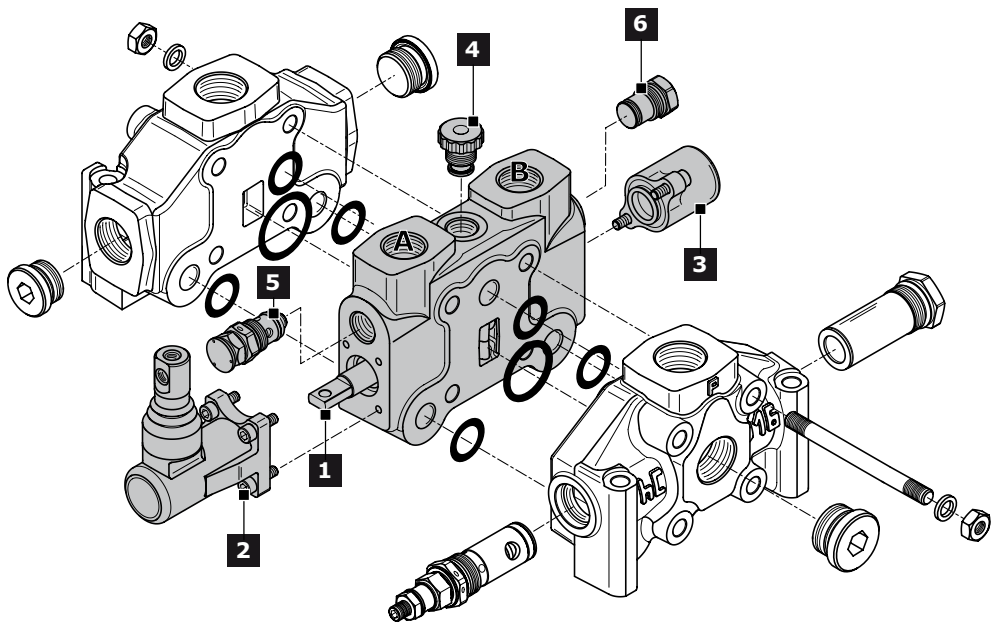

Rif.	Code	Description	Page
1	<b>W001</b>	3 positions double-acting	14
	<b>W002</b>	3 positions double-acting A-B to tank	
2	<b>H001</b>	Protected lever	16
	<b>H005</b>	hydraulic actuation	
3	<b>F001A</b>	3 positions spring-centred spool (spring A)	17
	<b>F002A</b>	3 positions spring-centred spool detent in A and B (spring A)	
4	<b>RP G05</b>	Parallel circuit (G 3/4)	25
	<b>RP U05</b>	Parallel circuit (1"1/16-12 UNF)	
	<b>RS G05</b>	Series circuit (G 3/4)	
	<b>RS U05</b>	Series circuit (1"1/16-12 UNF)	
5	<b>01 PA 100</b>	Antishock valve (port A)	26
	<b>05 PA</b>	Prearrangement for auxiliary valve (port A)	
6	<b>01 PB 100</b>	Antishock valve (port B)	26
	<b>05 PB</b>	Prearrangement for auxiliary valve (port B)	

**NOTE:** (\*) Leave out the spool return action code when choosing H005.  
 Sections designed to house auxiliary valve option require double choice on work ports A and B.  
 Always indicate setting value when using antishock and combined valve: **01 PA (100) - 03 PA (100)**



Spool identification

order example of spool: **W001 A J10**

<b>W001</b>	spool schema	3 positions double-acting	_____
<b>A</b>	spool type	standard spool	_____
<b>J10</b>	restricted service ports	restriction on diameter (0,10 mm in A and B)	_____

<b>W001</b>	3 positions double-acting	
<b>W002</b>	3 positions double-acting A and B to tank	
<b>W003</b>	3 positions double-acting A to tank B blocked	
<b>W004</b>	3 positions double-acting A blocked B to tank	
<b>W005</b>	3 positions single - acting on A	
<b>W006</b>	3 positions single - acting on B	
<b>W009</b>	3 positions double-acting with anticavitation valves	
<b>W010</b>	3 positions double-acting switch port closed (A - B blocked)	
<b>W011</b>	3 positions double-acting switch port closed (A - B to tank)	
<b>W012</b>	4 positions double-acting with float in the 4th position	
<b>W013</b>	3 positions double-acting regenerative	
<b>W015</b>	3 positions double-acting series	
<b>W016</b>	3 positions double-acting series A and B to tank	



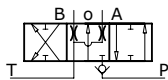
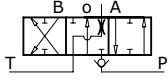
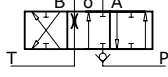

spools with restricted service ports				
code	circuit	restriction on diameter (mm)	section (mm <sup>2</sup> )	hydraulic schema
<b>J10</b>	A-B IN T	0,10	3,13	
<b>K10</b>	A IN T	0,10	3,13	
<b>Y10</b>	B IN T	0,10	3,13	

CODE	spool type available	
	STANDARD	METERED
	A	B
<b>W001</b>	W001A	W001B
<b>W002</b>	W002A	W002B
<b>W003</b>	W003A	W003B
<b>W004</b>	W004A	W004B
<b>W005</b>	W005A	W005B
<b>W006</b>	W006A	W006B
<b>W009</b>	W009A	W009B
<b>W010</b>	W010A	
<b>W011</b>	W011A	
<b>W012</b>	W012A	
<b>W013</b>	W013A	
<b>W015</b>	W015A	
<b>W016</b>	W016A	

**NOTE:**

- W012, W013, spools need a special machining on the valve body.
- W015, W016, spools need RS type body.
- Float spool (W012) need special detent kit (F005).
- Regenerative spool (W013) need special return spring kits.
- Different spools are available on request.

Plaese contact our Sales department for more information.



**Spool actuation classification for manual control**

code	description	dimensions	configuration
H001	Protected lever		
H002	Protected lever rotated 180°		
H004	Control without lever		

**Spool actuation classification for Hydraulic control**

code	description	dimensions	configuration
H006	Hydraulic actuation with side ports and cast-iron end caps  BSP ports = G 1/4 UNF ports = 9/16-18 UNF		

**Hydraulic pilot control curve**

The diagram shows the spool stroke as a function of the pressure operating.

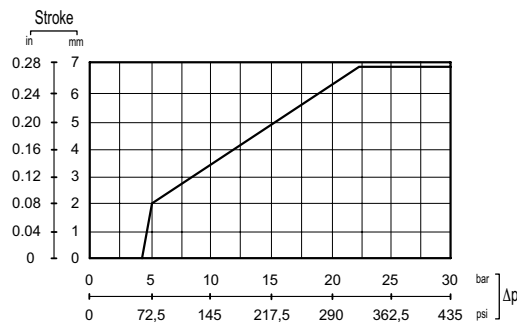



**Spool return action classification - Springs load values**

Spool return kits have three different spring types; following the codes depending on spring loads.

Spring type			
Code	A (standard spring)	B (soft spring)	C (heavy spring)
<b>Preloading</b>	137.3 N	98.1 N	196.2 N
<b>End of stroke</b>	176.6 N	137.3 N	255 N
Spool return action identification example			
<b>Code</b>	<b>F001A</b>	<b>F001B</b>	<b>F001C</b>

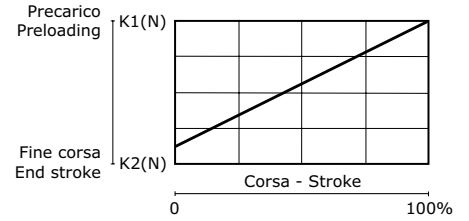

code	description	schema	dimensions	configuration
<b>F001A</b> <b>F001B</b> <b>F001C</b>	3 positions spring-centred spool			
<b>F002A</b>	3 positions spring-centred spool detent in A and B			
<b>F003A</b>	3 positions spring-centred spool detent in A			
<b>F004A</b>	3 positions spring-centred spool detent in B			
<b>F005A</b>	4 positions spring-centred spool detent in 4 <sup>th</sup> position  (only for W012 spool)			
<b>F009A</b>	2 positions in A spring-centred spool			
<b>F010A</b>	2 positions in B spring-centred spool			
<b>F011A</b>	2 positions detent in A spring-centred spool			
<b>F012A</b>	2 positions detent in B spring-centred spool			
<b>F013A</b> <b>F013B</b> <b>F013C</b>	3 positions spring-centred spool prearrangement dual command			



Pneumatic control classification

code	description	schema	dimensions	configuration
F020A	Pneumatic control ON - OFF		<p>Proportional control with port BSP: G 1/8</p>	
F021A	Pneumatic control ON - OFF rotated 180°			
F022A	Proportional Pneumatic control		<p>Proportional control with port NPTF: 1/8-27</p>	
F023A	Proportional Pneumatic control rotated 180°			
F135A	Pneumatic control ON - OFF		<p>Proportional control with port NPTF: 1/8-27</p>	
F136A	Pneumatic control ON - OFF rotated 180°			
F126A	Proportional Pneumatic control		<p>Proportional control with port NPTF: 1/8-27</p>	
F127A	Proportional Pneumatic control rotated 180°			

Proportional pneumatic control curve

The diagram shows the spool stroke as a function of the pneumatic pressure operating.

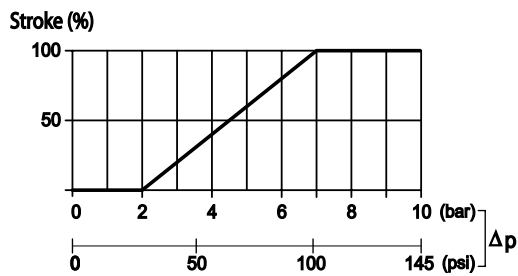



**Load limit classification**

code	description	schema	dimensions	configuration
<b>F024A</b> <b>F024C</b>	Load limit in A and B			
<b>F025A</b> <b>F025C</b>	Load limit in A and B rotated 180°			
<b>F026A</b> <b>F026C</b>	Load limit in A			
<b>F027A</b> <b>F027C</b>	Load limit in A rotated 180°			
<b>F028A</b> <b>F028C</b>	Load limit in B			
<b>F029A</b> <b>F029C</b>	Load limit in B rotated 180°			

**NOTE:** on request is available the load limit with dual control; for more informations please contact our Commercial Dept.



**Electrical load limit classification**

Spool position sensor			
Power supply	Contacts capacity	Protection degree	temperature range
12 vdc	3 A	IP 65	da -25°C a +90°C
24 vdc	1,5 A		

**Operational diagram**

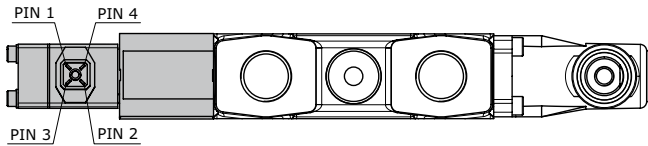

**CONTROL in A e B** = connect PIN 1 - 4 and 2 - 3  
**CONTROL in A** = connect PIN2 - 3  
**CONTROL in B** = connect PIN 1 - 4

**Wiring diagram**

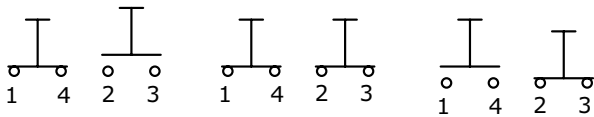

In case of inductive loads it is advisable to connect the terminals of the workport (solenoid) to a 200 VDC - 3A diode.

controllo utilizzo A      neutro in = 0      controllo utilizzo B

code	description	dimensions	configuration
<b>F0360</b>	Electrical load limit (normally closed contacts)		
<b>F0370</b>	Electrical load limit rotated 180° (normally closed contacts)		
<b>F0450</b>	Electrical load limit (normally open contacts)		
<b>F0460</b>	Electrical load limit rotated 180° (normally open contacts)		

**NOTE:** a HIRSCHMANN female connector, type G4 W1F, is available on request (code 413000045, to be ordered separately).



**Electrohydraulic control specifications**

Operating temperature range	-20°C / +80°C
Max inlet pressure	350 bar
Reduced pressure	16 bar
Back pressure on (T)	3 bar
Filtering degree	25 μ assoluti
Raccommended pilot pipe size	Ø 6 mm - G 1/4

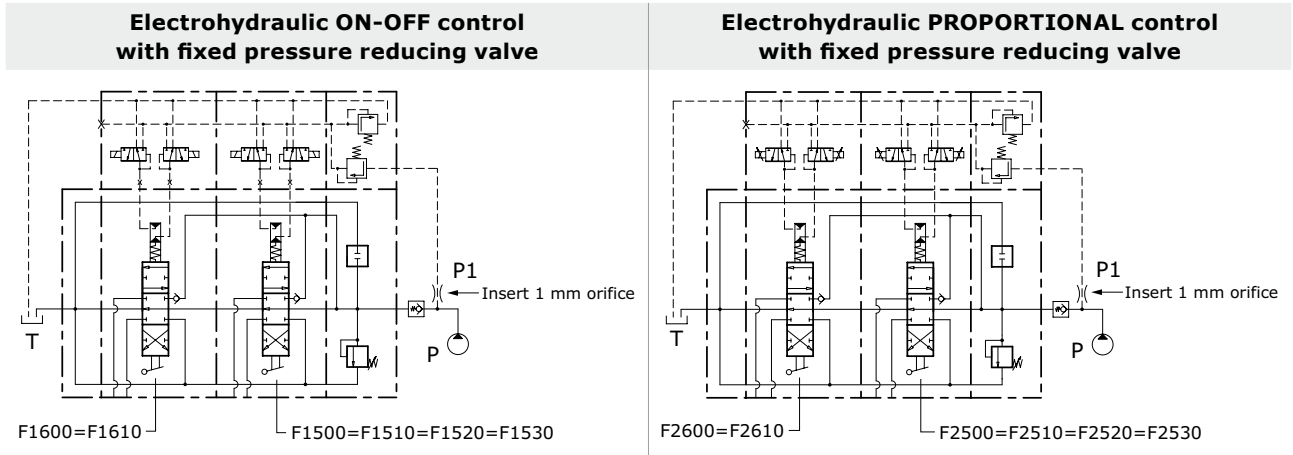

Proportional control kit, mechanically retrooperated, allows the maximum precision of positioning, limiting the hysteresis. The control is operated with PWM control of the current. PWM frequency suggest: 60-80 Hz

Nominal voltage (V)	regulation currents		
	Resistance R <sub>20</sub> (Ohm)	Current min (A)	Current max (A)
12 vdc	3,7	0,9	1,7
24 vdc	15,5	0,45	0,85

**Electrohydraulic control classification**

code	description	dimensions	configuration
<b>F1600</b>	3 positions electrohydraulic control ON - OFF 12 Vdc		
<b>F1610</b>	3 positions electrohydraulic control ON - OFF 24 Vdc		
<b>F2600</b>	3 positions electrohydraulic control PROPORTIONAL 12 Vdc		
<b>F2610</b>	3 positions electrohydraulic control PROPORTIONAL 24 Vdc		

Electrohydraulic ON-OFF control is stackable with electrohydraulic PROPORTIONAL control (F2600 = F2610). Control kit already includes orifice to make spool displacement more gradual.

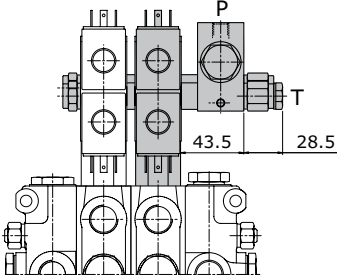
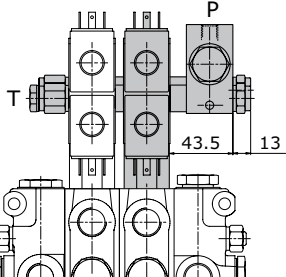

**Electrohydraulic control with fixed pressure reducing valve classification**

code	description	configuration
<b>F1500</b>	Electrohydraulic control ON - OFF (fixed pressure reducing valve) P - T inlet side (12 vdc)	 <p>Port BSP (P - T) = G 1/4 Port UNF (P - T) = 9/16"18 UNF</p>
<b>F1510</b>	Electrohydraulic control ON - OFF (fixed pressure reducing valve) P - T inlet side (24 vdc)	
<b>F2500</b>	Electrohydraulic control PROPORTIONAL (fixed pressure reducing valve) P - T inlet side (12 vdc)	
<b>F2510</b>	Electrohydraulic control PROPORTIONAL (fixed pressure reducing valve) P - T inlet side (24 vdc)	
<b>F1520</b>	Electrohydraulic control ON - OFF (fixed pressure reducing valve) P inlet - T outlet (12 vdc)	 <p>Port BSP (P - T) = G 1/4 Port UNF (P - T) = 9/16"18 UNF</p>
<b>F1530</b>	Electrohydraulic control ON - OFF (fixed pressure reducing valve) P inlet - T outlet (24 vdc)	
<b>F2520</b>	Electrohydraulic control PROPORTIONAL (fixed pressure reducing valve) P inlet - T outlet (12 vdc)	
<b>F2530</b>	Electrohydraulic control PROPORTIONAL (fixed pressure reducing valve) P inlet - T outlet (24 vdc)	

**Control tie rod assembly**

The length of the control tie rod, will change depending on the section numbers; in this way it will be easy to install in the right way the sections and avoid any misassembly. Each kit is composed by 2 tie rods, 2 plugs, 2 connection ports and spacers according to the section number.

**NOTE:** the control tie rod kit has always to be ordered separately.

Reducing valve, combined with electrohydraulic control kit has to be calculated as a normal working section.

**ORDER EXAMPLE:**

Complete valves with 3 sections F1600 requires a complete tie-rod kit /3.

Complete valves with 2 sections F1600 and 1 section with F1500 (reducing valve) requires a complete tie-rod kit /4.

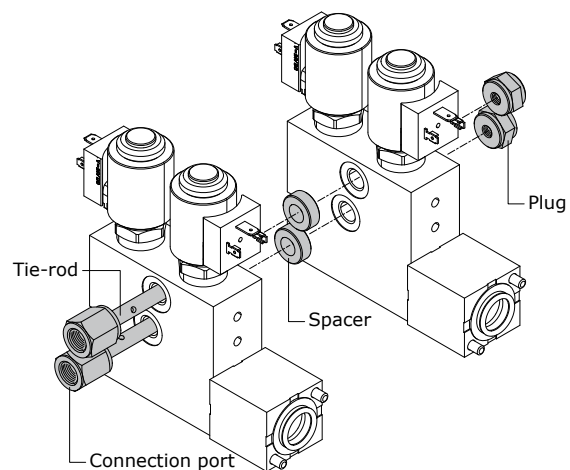





**Order code fixed pressure reducing valve:**

**915000303** = reducing valve for BSP ports  
**915000312** = reducing valve for UNF ports

**Order code for control tie rod (BSP):**

**320103001** = control tie rod /1  
**320105001** = control tie rod /2  
**320105002** = control tie rod /3  
**320105003** = control tie rod /4  
**320105004** = control tie rod /5  
**320105005** = control tie rod /6  
**320105006** = control tie rod /7  
**320105007** = control tie rod /8  
**320105008** = control tie rod /9

**Order code for control tie rod (UNF):**

**320103026** = control tie rod /1  
**320105026** = control tie rod /2  
**320105027** = control tie rod /3  
**320105028** = control tie rod /4  
**320105029** = control tie rod /5  
**320105030** = control tie rod /6  
**320105031** = control tie rod /7  
**320105032** = control tie rod /8  
**320105033** = control tie rod /9

**Electropneumatic control classification**

code	description	dimensions	configuration
<b>F0620</b>	3 positions electropneumatic control ON-OFF (12 vdc) 7 W - 0,58 A	Minimum working pressure  5 bar	
<b>F0630</b>	3 positions electropneumatic control ON-OFF (24 vdc) 7 W - 0,29 A		

**Control tie rod assembly**

The length of the control tie rod, will change depending on the section numbers; in this way it will be easy to install in the right way the sections and avoid any misassembly. Each kit is composed by 1 tie rod and 2 plugs.

**NOTE:** the control tie rod kit has always to be ordered separately.

**Order code for control tie rod (BSP):**

**320105013** = control tie rod /1  
**320105014** = control tie rod /2  
**320105015** = control tie rod /3  
**320105016** = control tie rod /4  
**320105017** = control tie rod /5  
**320105018** = control tie rod /6  
**320105019** = control tie rod /7  
**320105020** = control tie rod /8

**Order code for control tie rod (UNF):**

**320105037** = control tie rod /1  
**320105038** = control tie rod /2  
**320105039** = control tie rod /3  
**320105040** = control tie rod /4  
**320105041** = control tie rod /5  
**320105042** = control tie rod /6  
**320105043** = control tie rod /7  
**320105044** = control tie rod /8



Compatibility table

SPOOL ACTION TYPE	SPOOL TYPE																				
	W001A	W001B	W002A	W002B	W003A	W003B	W004A	W004B	W005A	W005B	W006A	W006B	W009A	W009B	W010A	W011A	W012A	W013A	W015A	W016A	
H001	•	•	•	•	•	•	•	•	•	•	•	•	•	•	•	•	•	•	•	•	•
H002	•	•	•	•	•	•	•	•	•	•	•	•	•	•	•	•	•	•	•	•	•
H004	•	•	•	•	•	•	•	•	•	•	•	•	•	•	•	•	•	•	•	•	•
H006	•	•	•	•	•	•	•	•	•	•	•	•	•	•	•	•	•	•	•	•	•
SPOOL RETURN ACTION TYPE	SPOOL TYPE																				
	W001A	W001B	W002A	W002B	W003A	W003B	W004A	W004B	W005A	W005B	W006A	W006B	W009A	W009B	W010A	W011A	W012A	W013A	W015A	W016A	
F001	•	•	•	•	•	•	•	•	•	•	•	•	•	•	•	•		•	•	•	
F002	•	•	•	•	•	•	•	•	•	•	•	•	•	•	•	•			•	•	
F003	•	•	•	•	•	•	•	•	•	•	•	•	•	•	•	•			•	•	
F004	•	•	•	•	•	•	•	•	•	•	•	•	•	•	•	•			•	•	
F005																	•				
F009	•	•	•	•	•	•	•	•					•	•	•	•			•	•	
F010	•	•	•	•	•	•	•	•					•	•	•	•			•	•	
F011	•	•	•	•	•	•	•	•					•	•	•	•			•	•	
F012	•	•	•	•	•	•	•	•					•	•	•	•			•	•	
F013	•	•	•	•	•	•	•	•	•	•	•	•	•	•	•	•		•	•	•	
F020=F021	•	•	•	•	•	•	•	•	•	•	•	•	•	•	•	•		•	•	•	
F022=F023	•	•	•	•	•	•	•	•	•	•	•	•	•	•	•	•		•	•	•	
F135=F136	•	•	•	•	•	•	•	•	•	•	•	•	•	•	•	•		•	•	•	
F126=F127	•	•	•	•	•	•	•	•	•	•	•	•	•	•	•	•		•	•	•	
F024=F025	•	•	•	•	•	•	•	•					•	•	•	•			•	•	
F026=F027	•	•	•	•	•	•	•	•					•	•	•	•			•	•	
F028=F029	•	•	•	•	•	•	•	•					•	•	•	•			•	•	
F0360=F0370	•	•	•	•	•	•	•	•	•	•	•	•	•	•	•	•			•	•	
F0450=F0460	•	•	•	•	•	•	•	•	•	•	•	•	•	•	•	•			•	•	
F0620=F0630	•	•	•	•	•	•	•	•					•	•	•	•		•	•	•	
F1500=F1510	•	•	•	•	•	•	•	•	•	•	•	•	•	•	•	•		•	•	•	
F1520=F1530	•	•	•	•	•	•	•	•	•	•	•	•	•	•	•	•		•	•	•	
F2500=F2510	•	•	•	•	•	•	•	•	•	•	•	•	•	•	•	•		•	•	•	
F2520=F2530	•	•	•	•	•	•	•	•	•	•	•	•	•	•	•	•		•	•	•	
F1600=F1610	•	•	•	•	•	•	•	•	•	•	•	•	•	•	•	•		•	•	•	
F2600=F2610	•	•	•	•	•	•	•	•	•	•	•	•	•	•	•	•		•	•	•	



**Work section identification**

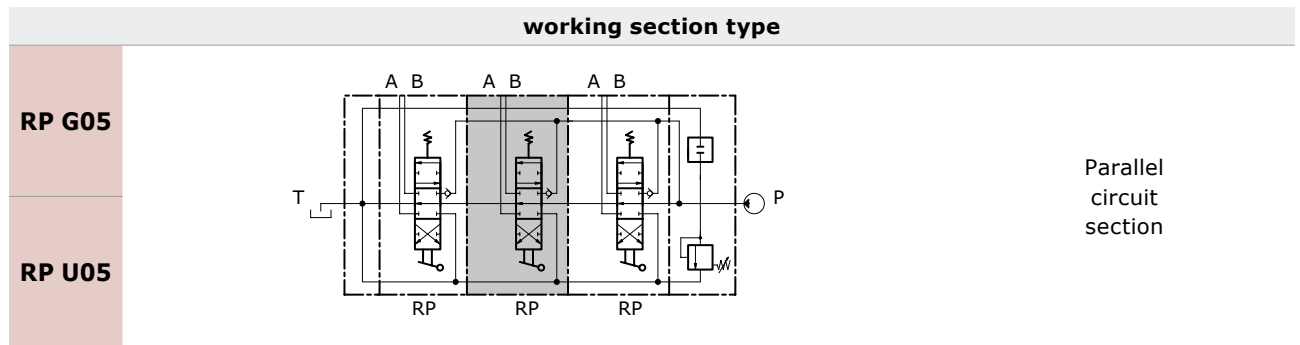

Parallel circuit section

When the spool is operated it intercepts the by-pass gallery by diverting the flow of oil to service port A or B. If two or more spools are actuated at the same time, the oil will power the service port that has the lower load; by throttling the spools, the flow of oil can be divided between two or more service ports.

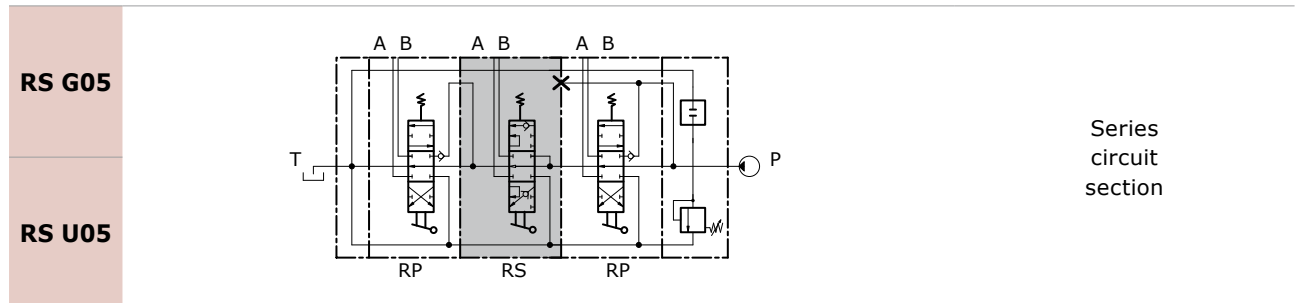









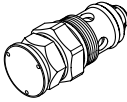

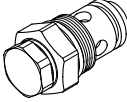

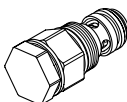

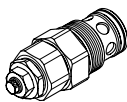

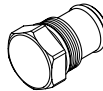

Series circuit section

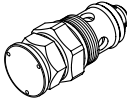
When the spool is operated it intercepts the switch gallery by diverting the flow of oil to service port A or B. The oil that flows back from the actuator is carried to the switch gallery thus making it available to the service ports downstream from the series section. The pressure drop downstream is added to the pressure drop of the section itself.

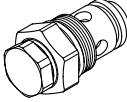

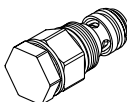
**Auxiliary valve identification**

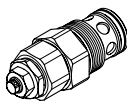
code	description	schema	sonfiguration	setting range (bar)			
				type	at full flow	type	at min. flow
<b>01 PA</b>	Antishock valve (port A)			<b>A</b>	70 / 150	<b>A</b>	70-A / 120-A
				<b>B</b>	151 / 230	<b>B</b>	121-A / 200-A
				<b>C</b>	231 / 280	<b>C</b>	201-A / 250-A
				<b>D</b>	281 / 350	<b>D</b>	251-A / 350-A
<b>02 PA</b>	Anticavitation valve (port A)						
<b>03 PA</b>	Combined valve (port A)			<b>A</b>	30 / 95	<b>A</b>	30-A / 65-A
				<b>B</b>	96 / 150	<b>B</b>	66-A / 120-A
				<b>C</b>	151 / 260	<b>C</b>	121-A / 230-A
				<b>D</b>	261 / 350	<b>C</b>	231-A / 350-A
<b>04 PA</b>	Pilot combined valve (port A)			<b>A</b>	50 / 420	<b>A</b>	50-A / 420-A
<b>05 PA</b>	Prearrangement for auxiliary valve (port A)						

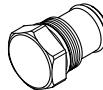
code	description	schema	sonfiguration	setting range (bar)			
				type	at full flow	type	at min. flow
<b>01 PB</b>	Antishock valve (port B)			<b>A</b>	70 / 150	<b>A</b>	70-A / 120-A
				<b>B</b>	151 / 230	<b>B</b>	121-A / 200-A
				<b>C</b>	231 / 280	<b>C</b>	201-A / 250-A
				<b>D</b>	281 / 350	<b>D</b>	251-A / 350-A
<b>02 PB</b>	Anticavitation valve (port B)						
<b>03 PB</b>	Combined valve (port B)			<b>A</b>	30 / 95	<b>A</b>	30-A / 65-A
				<b>B</b>	96 / 150	<b>B</b>	66-A / 120-A
				<b>C</b>	151 / 260	<b>C</b>	121-A / 230-A
				<b>D</b>	261 / 350	<b>C</b>	231-A / 350-A
<b>04 PB</b>	Pilot combined valve (port B)			<b>A</b>	50 / 420	<b>A</b>	50-A / 420-A
<b>05 PB</b>	Prearrangement for auxiliary valve (port B)						

**Auxiliary valve - Setting range**

Sections designed to house auxiliary valve option require double choice on work ports A and B. Always indicate setting value when using antishock valve:

**01 PA (120) = setting at full flow**  
**01 PA (120-A) = setting at min. flow**



**INTERMEDIATE INLET SECTION**

Order example

<b>BE</b>	<b>009</b>	<b>150</b>	<b>A G05</b>
-----------	------------	------------	--------------

- BE** inlet side
- 1. 009** valve arrangement
- 150** setting (bar); when ordering a main relief valve it is necessary to specify setting
- 2. A G05** inlet position and available thread type

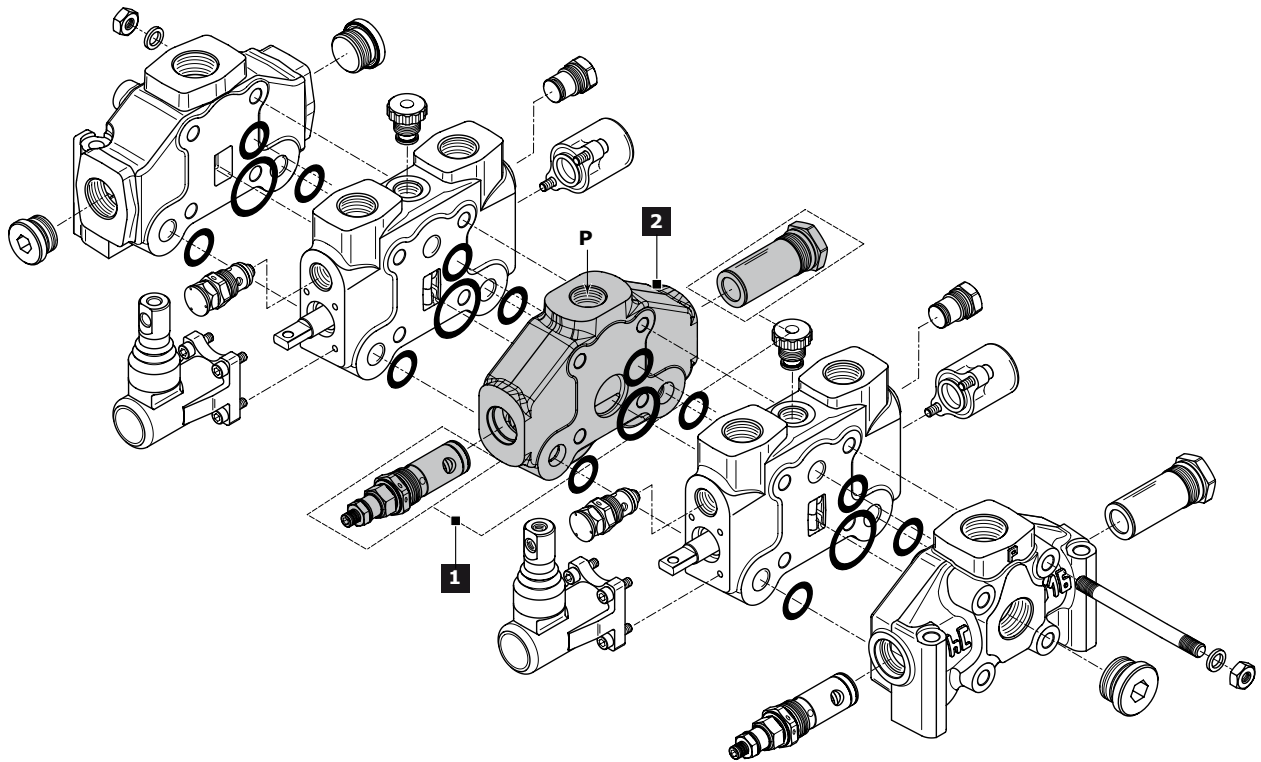

Rif.	Code	Description	Page
-	<b>BE</b> <b>BV*</b>	Intermediate inlet section Intermediate inlet section with pressure relief valve	<b>28</b>
<b>1</b>	<b>009</b> <b>010</b> <b>019</b> <b>020</b>	Pilot operated pressure relief valve Pilot operated pressure relief valve and Main anticavitation check valve Without valves Main anticavitation check valve	<b>29</b>
<b>2</b>	<b>A G05</b> <b>A U05</b>	Upper inlet (thread G 3/4) Upper inlet (thread 1"1/16-12 UNF)	

**NOTE:** when ordering a relief valve it is necessary to specify factory setting (example 150).  
\* = omit the code for inlet positioning and thread



Intermediate inlet section classifications

intermediate inlet type

BE

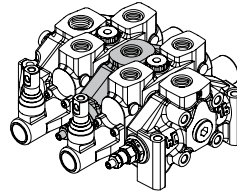
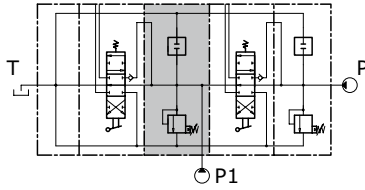

Intermediate inlet section

The intermediate inlet section is driven by two pumps (P + P1). The downstream elements can be set to a lower pressure than the upstream ones by adjusting the pressure relief valve of the intermediate section in question.

BV

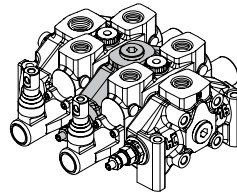
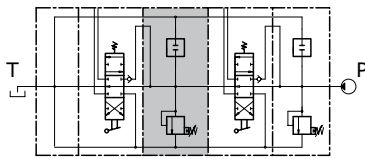

Intermediate inlet section with pressure relief valve

The intermediate inlet section and the elements are driven by a single pump (P). The downstream elements can be set to a lower pressure than the upstream ones by adjusting the pressure relief valve of the intermediate section in question.

Valve identification on intermediate inlet section

type	schema	layout	description	type	schema	configurazione	descrizione
2			Pilot operated pressure relief valve	4			Externally piloted valve
3			Relief valve plugged	11			Plug with pressure-gauge connection

Valve arrangement on intermediate inlet section

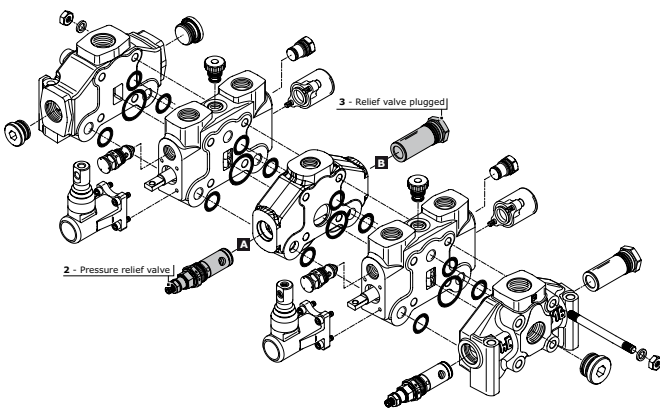

Combination valve example: 009 = 2A - 3B

- 009 Combination valve
- 2A Pressure relief valve in port A
- 3B Relief valve plugged in port B

The code identifies:

with a number, the type of valve; with a letter its position on the inlet section.

- (A) = spool action side
- (B) = spool return action side

**NOTE:** when ordering a main relief valve it is necessary to specify setting



VALVE COMBINATION INLET SECTION		Valve type on port B			
		2	3	4	11
Valve type on port A	2		009	010	016
	3	018	019	020	027
	4	029	030		
	11	085	086		

**Inlet position and available thread type**

Inlet combination and thread available	
<b>A G05</b>	<p>Upper inlet (P1)</p>
<b>A U05</b>	

**Complete configuration samples for D16/2 with intermediate inlet section (BE)**

- IR 009 150 A G05..... Right inlet section
- W001A H001 F001A RP G05 ..... Working section
- BE 009 150 A G05 .....Intermediate inlet section**
- W001A H001 F001A RP G05 ..... Working section
- TJ A G06 ..... Outlet section

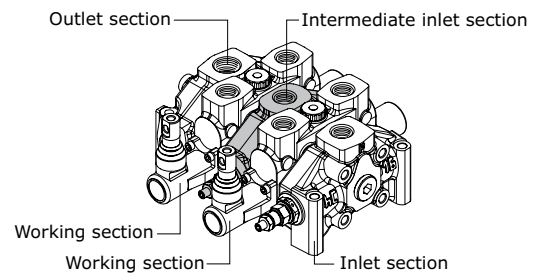

**Complete configuration samples for D16/2 with intermediate inlet section (BV)**

- IR 009 150 A G05..... Right inlet section
- W001A H001 F001A RP G05 ..... Working section
- BV 009 150 .....Intermediate inlet section**
- W001A H001 F001A RP G05 ..... Working section
- TJ A G06 ..... Outlet section

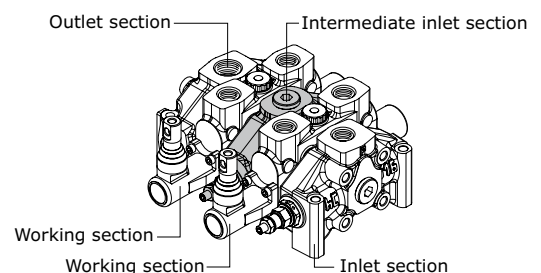



INTERMEDIATE OUTLET SECTION

Order example

**BF** | **A G06**

1. **BF** inlet side \_\_\_\_\_  
**A G06** inlet position and available thread type \_\_\_\_\_

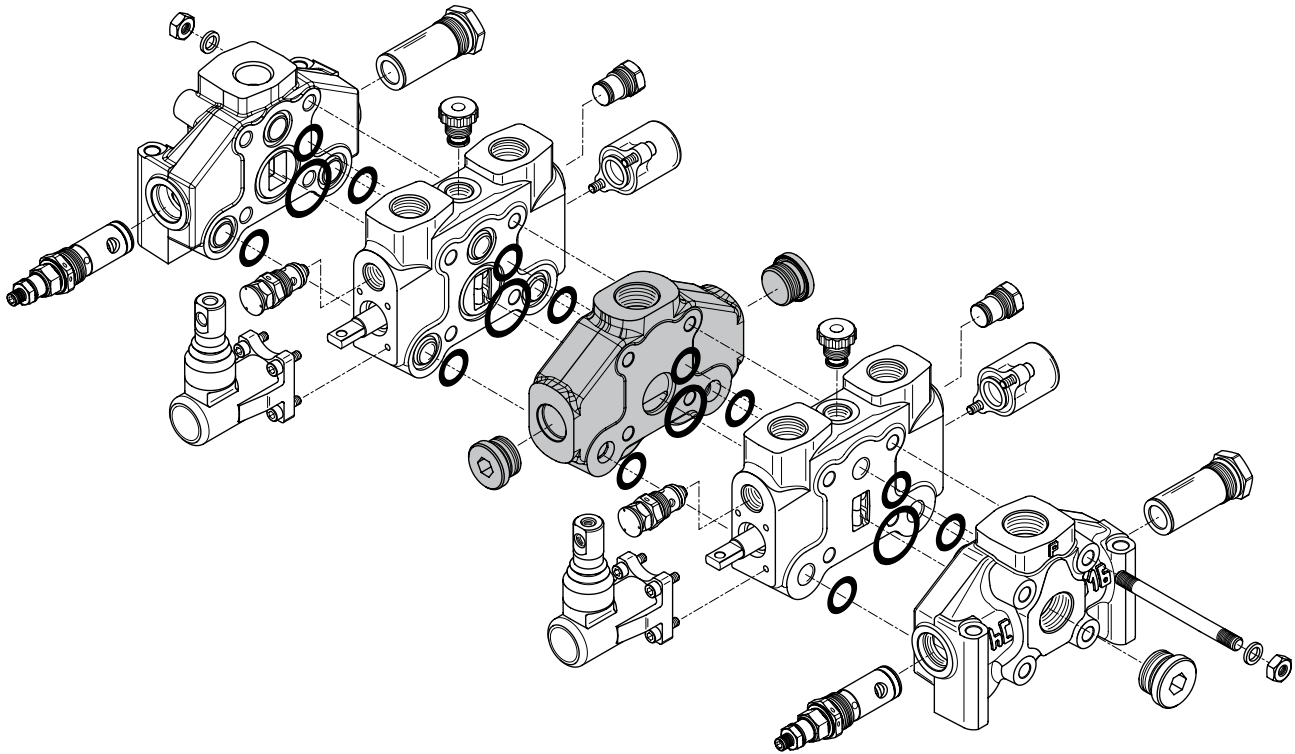

Rif.	Code	Type	Description	Page
-	<b>BF</b>		Intermediate outlet section with single tank return	
-	<b>BG</b>		Intermediate outlet section with two tank returns	
1	<b>A G06</b>		Upper outlet (thread G 1)	31
	<b>A U06</b>		Upper outlet (thread 1"5/16-12 UNF)	
	<b>G G06</b>	for	Front outlet side A (thread G 1)	
	<b>G U06</b>	BF	Front outlet side A (thread 1"5/16-12 UNF)	
	<b>H G06</b>		Rear outlet side B (thread G 1)	
	<b>H U06</b>		Rear outlet side B (thread 1"5/16-12 UNF)	
	<b>J G06</b>	for	Upper outlet HPCO - front side A and rear side B to T (thread G 1)	
	<b>J U06</b>	BG	Upper outlet HPCO-front side A and rear side B to T (thread 1"5/16-12 UNF)	



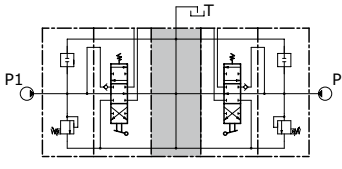
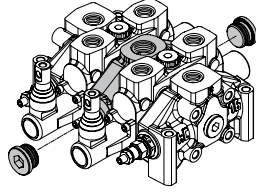

**Intermediate outlet section classifications**

intermediate outlet type		
<b>BF</b>		 <p style="text-align: center;">Intermediate outlet section <b>with single tank return</b></p>

The above outlet section allows the flow of oil of the two pumps and the tank ports to be piped to a single outlet T.

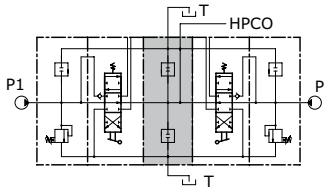
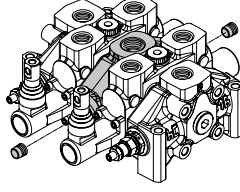
<b>BG</b>		 <p style="text-align: center;">Intermediate outlet section <b>with two tank returns</b></p>
-----------	---	--

The section in question allows the flow of oil of the two pumps to be piped in two outlets: HPCO for powering another directional control valve, T for discharge of the work ports. In order to obtain this, the two T need to be linked.

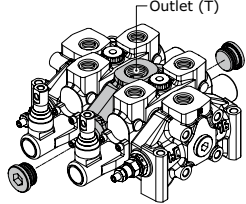
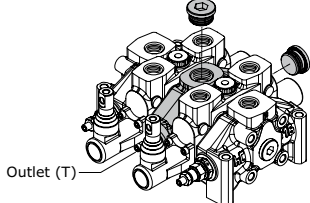
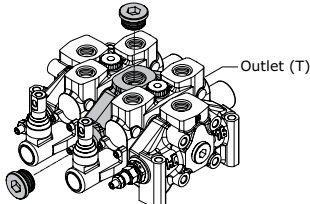
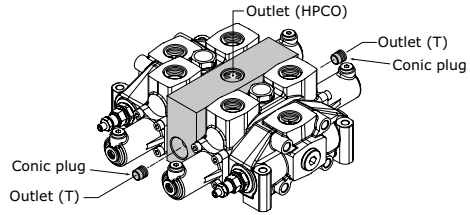
Outlet combination and thread available			
<b>A G06</b>		available only for <b>BF</b>	Upper outlet (T)
<b>A U06</b>			
<b>G G06</b>		available only for <b>BF</b>	Front outlet side A (T)
<b>G U06</b>			
<b>H G06</b>		available only for <b>BF</b>	Rear outlet side B (T)
<b>H U06</b>			
<b>J G06</b>		available only for <b>BF</b>	Upper outlet HPCO front side A and rear side B to T
<b>J U06</b>			



**Complete configuration samples for D16/2 with intermediate outlet section (BF)**

IR 009 150 A G05..... Right inlet section

W001A H001 F001A RP G05 ..... Working section

**BF A G06 .....Intermediate outlet section**

W001A H001 F001A RP G05 ..... Working section

IL 009 150 A G05..... Left inlet section

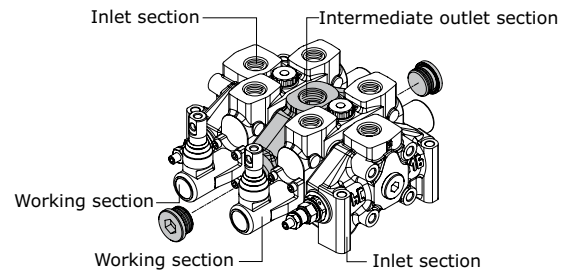

**Complete configuration samples for D16/2 with intermediate outlet section (BG)**

IR 009 150 A G05..... Right inlet section

W001A H001 F001A RP G05 ..... Working section

**BG J G06 .....Intermediate outlet section**

W001A H001 F001A RP G05 ..... Working section

IL 009 150 A G05..... Left inlet section

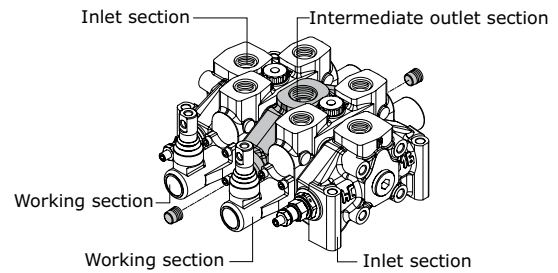



**OUTLET SECTION (VERSION 1 OUTLET)**

**Order example**

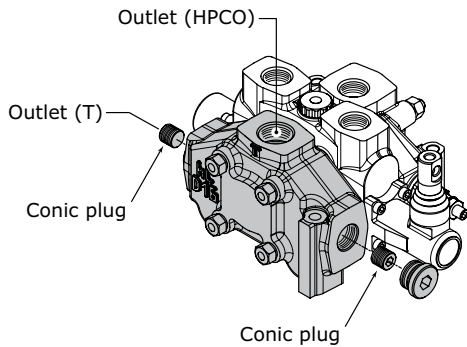

**TJ** | **A G06**

- 1. **TJ** outlet section type
- 2. **A G06** outlet position and available thread type

Rif.	Code	Description	Page
1	<b>TJ</b>	Outlet section with single return (T) right-side inlet (P)	34
	<b>TK</b>	Outlet section with single return (T) left-side inlet (P)	
2	<b>A G06</b>	Upper outlet (thread G 1)	
	<b>A U06</b>	Upper outlet (thread 1"5/16-12 UNF)	
	<b>C G06</b>	Central outlet (thread G 1)	
	<b>C U06</b>	Central outlet (thread 1"5/16-12 UNF)	

**OUTLET SECTION (HPCO VERSION OUTLET)**

**Order example - HPCO version Outlet**

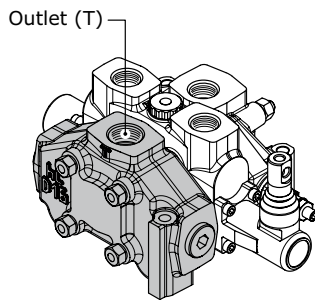

**TM** | **M G06**

- 1. **TM** outlet section type
- 2. **M G06** outlet position and available thread type

Rif.	Code	Description	Page
1	<b>TM</b>	Outlet section with two return (T-HPCO) right-side inlet (P)	35
	<b>TN</b>	Outlet section with two return (T-HPCO) left-side inlet (P)	
2	<b>M G06</b>	HPCO upper outlet T (tank) rear outlet side B (thread G 1)	
	<b>M U06</b>	HPCO upper outlet T (tank) rear outlet side B (thread 1"5/16-12 UNF)	
	<b>N G06</b>	HPCO upper outlet T (tank) front outlet side A (thread G 1)	
	<b>N U06</b>	HPCO upper outlet T (tank) front outlet side A (thread 1"5/16-12 UNF)	



Outlet with single tank classification

outlet identification

**TJ**

Outlet section with single return (T)  
right-side inlet (P)

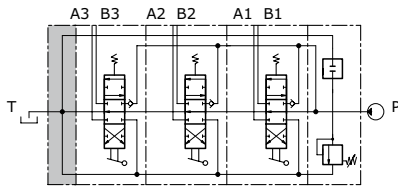

Outlet (T)      Inlet (P)

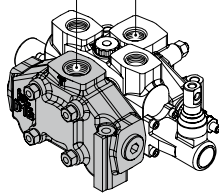

**TK**

Outlet section with single return (T)  
left-side inlet (P)

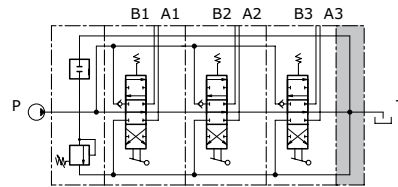

Inlet (P)      Outlet (T)

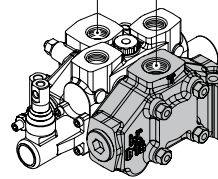

outlet combination and thread available

**A G06**

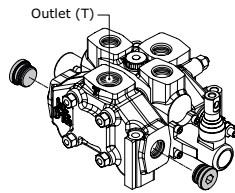

Upper outlet  
(thread G 1)

**A U06**

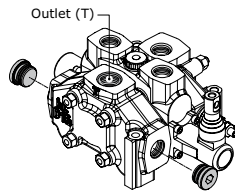

Upper outlet  
(thread 1"5/16 - 12 UNF)

**C G06**

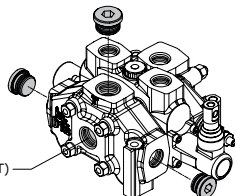

Central outlet  
(thread G 1)

**C U06**



Central outlet  
(thread 1"5/16 - 12 UNF)

**G G06**

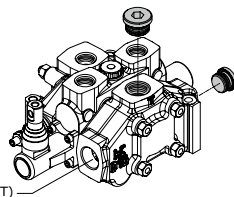

**only for  
TK**

Front outlet side A  
(thread G 1)

**G U06**

Outlet (T)

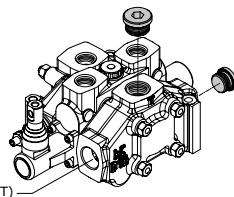

Front outlet side A  
(thread 1"5/16 - 12 UNF)

**H G06**

Outlet (T)

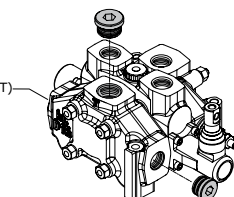

**only for  
TJ**

Rear outlet side B  
(thread G 1)

**H U06**

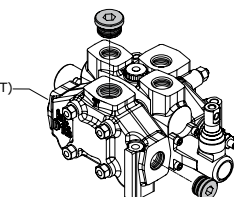

Rear outlet side B  
(thread 1"5/16 - 12 UNF)



Outlet with two tanks classification

outlet identification			
<b>TM</b>	<p>Outlet section with two return (T-HPCO) right-side inlet (P)</p>		
<b>TN</b>	<p>Outlet section with two return (T-HPCO) left-side inlet (P)</p>		
outlet combination and thread available			
<b>M G06</b>		<b>only for TM</b>	HPCO Upper outlet T (TANK) rear outlet side B (thread G 1)
<b>M U06</b>			HPCO Upper outlet T (TANK) rear outlet side B (thread 1"5/16 - 12 UNF)
<b>N G06</b>		<b>only for TN</b>	HPCO Upper outlet T (TANK) front outlet side A (thread G 1)
<b>N U06</b>			HPCO Upper outlet T (TANK) front outlet side A (thread 1"5/16 - 12 UNF)
<b>P G06</b>		<b>only for TM</b>	HPCO Central outlet T (TANK) rear outlet side B (thread G 1)
<b>P U06</b>			HPCO Central outlet T (TANK) rear outlet side B (thread 1"5/16 - 12 UNF)
<b>Q G06</b>		<b>only for TN</b>	HPCO Central outlet T (TANK) front outlet side A (thread G 1)
<b>Q U06</b>			HPCO Central outlet T (TANK) front outlet side A (thread 1"5/16 - 12 UNF)



**CARRY-OVER CONNECTION (HPCO)**

This option, available on all D16, allows the sectional valve to feed a second valve, by extending the free flow channel. In this configuration, the valve need a separated port for connection to tank.

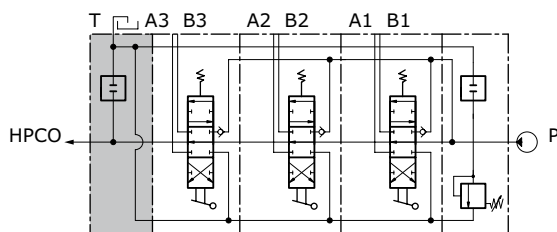

It is possible to transform sectional valve from standard to HPCO version just by ordering the appropriate conic plug:

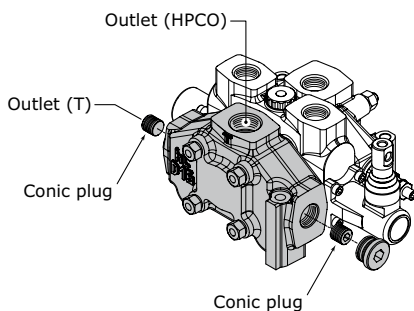

code (HPCO Plug identification)	description	q.ty
413010207	conic plug G 3/8 x 15	2



D6 SPARE PARTS LIST

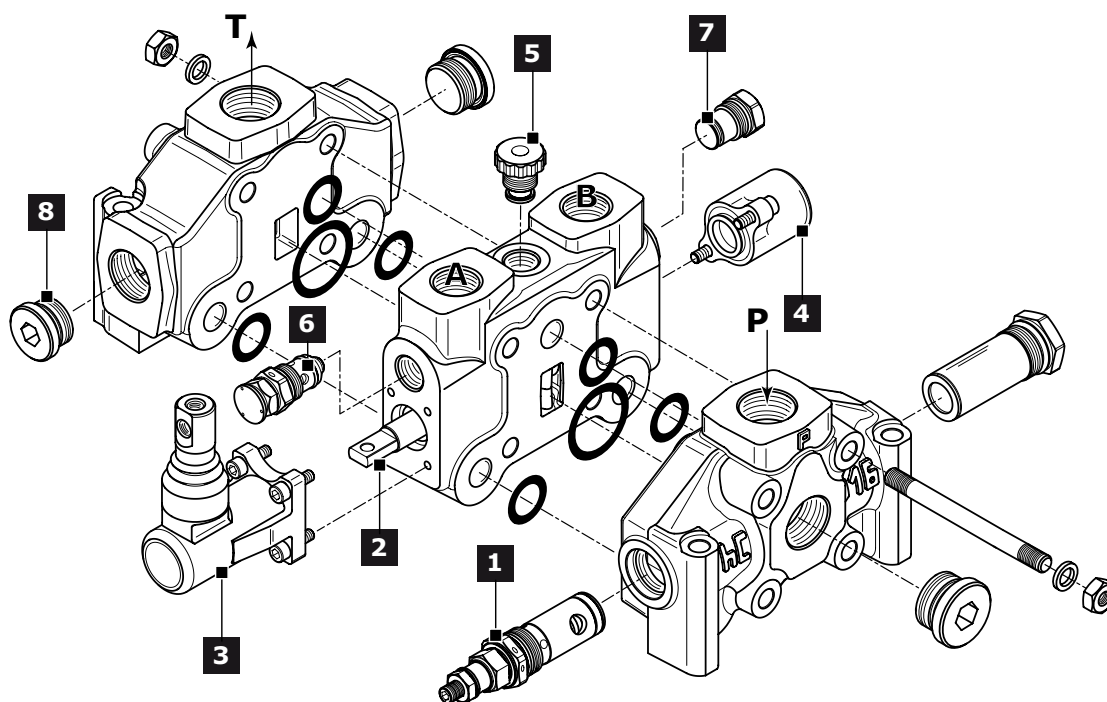

Ref.	Description	Order code	Q.ty	Code	Note
1	Pilot operated pressure relief valve (*)	6364	1		Setting: 100 bar
		2608			Setting: 200 bar
		2744			Setting: 300 bar
	Relief valve plugged	430107001	1		
	Main Anticavitation check valve	915050701	1	-	
	External piloted valve	915040701	1		
	Solenoid dump valve (12 vdc (**))	915040702	1		
Solenoid dump valve (24 vdc (**))	915040703	1			
Plug with pressure-gauge connection	430107003	1			
2	3 positions double-acting spool	421245016	1	W001A	
		421245028		W001B	
	3 positions double-acting A and B to tank spool	421245002	1	W002A	
		421245015		W002B	
	3 positions single-acting on A	421245005	1	W005A	
3 positions single-acting on B	421245021	1	W006A		
4 positions double-acting with float in the 4 <sup>th</sup> pos.	421245027	1	W012A		
3	Protected lever	320306006	1	H001 = H002	
		320306007			only for W012 spool
	Control without lever	320306002	1	H004	
		320306004			only for W012 spool
Hydraulic actuation with side ports	320545001	1	H006		



Ref.	Description	Order code	Q.ty	Code	Note
4	3 position spring centred spool	320706001	1	F001A	
	Detent in A and B	320806001	1	F002A	
	Detent in A	320806002	1	F003A	
	Detent in B	320806003	1	F004A	
	Detent in 4 <sup>th</sup> position	320806004	1	F005A	only for W012 spool
	Prearrangement dual command	320706002	1	F013A	
	Pneumatic control ON-OFF	321106002	1	F020A=F021A	BSP ports
	Proportional Pneumatic control	321206002	1	F022A=F023A	BSP ports
	Electropneumatic control ON-OFF (12 vdc)	321645001	1	F0620	
	Electropneumatic control ON-OFF (24 vdc)	321645002	1	F0630	
	Load limit in A and B	320045005	1	F024A=F025A	BSP ports
	Load limit in A	320045003	1	F026A=F027A	BSP ports
	Load limit in B	320045004	1	F028A=F029A	BSP ports
	Electrical load limit (normally closed contacts)	320045001	1	F0360=F0370	
	Electrical load limit (normally open contacts)	320045013	1	F0450=F0460	
	Electrohydraulic ON-OFF (12 vdc)	321445001	1	F1600	
	Electrohydraulic ON-OFF (24 vdc)	321445002	1	F1610	
	Electrohydraulic Proportional (12 vdc)	322045001	1	F2600	
	Electrohydraulic Proportional (24 vdc)	322045002	1	F2610	
	Electrohydraulic ON-OFF (12 vdc) with reducing valve	321445003	1	F1500=F1520	BSP ports
	Electrohydraulic ON-OFF (24 vdc) with reducing valve	321445004	1	F1510=F1530	BSP ports
	Electrohydraulic Proportional (12 vdc) with reducing valve	322045003	1	F2500=F2520	BSP ports
	Electrohydraulic Proportional (24 vdc) with reducing valve	322045004	1	F2510=F2530	BSP ports
Electrohydraulic ON-OFF (12 vdc) with reducing valve	321445005	1	F1500=F1520	UNF ports	
Electrohydraulic ON-OFF (24 vdc) with reducing valve	321445006	1	F1510=F1530	UNF ports	
Electrohydraulic Proportional (12 vdc) with reducing valve	322045006	1	F2500=F2520	UNF ports	
Electrohydraulic Proportional (24 vdc) with reducing valve	322045007	1	F2510=F2530	UNF ports	
5	Check valve on the work section	320204008	1	-	only for RP and RT section
6		4209			Setting: 100 bar
	Antishock valve on port A	2743		01 PA	Setting: 200 bar
		2948	1		Setting: 300 bar
	Anticavitation valve on port A	915080601		02 PA	
	Prearrangement for auxiliary valve on port A	430406001		05 PA	
7		4209			Setting: 100 bar
	Antishock valve on port B	2743		01 PB	Setting: 200 bar
		2948	1		Setting: 300 bar
	Anticavitation valve on port B	915080601		02 PB	
	Prearrangement for auxiliary valve on port B	430406001		05 PB	
8	Plug kit (G 3/4)	430000020		G05	
	Plug kit (G 1)	430000021	1	G06	
	Plug kit (1"1/12"-16 UNF)	300007002		U05	





**Note**

- (\*) = for different settings please contact our Sales Dpt.
- (\*\*) = electric dump valve coil can be ordered separately as spare part: (see drawing "A")  
Ordering code Coil 12 vdc: 413171235  
Ordering code Coil 24 vdc: 413172432
- (#) = Detent in A and B Kick-out is available only with special spool assembly

Coil - 12 Vdc = 413171235  
Coil - 24 Vdc = 413172432

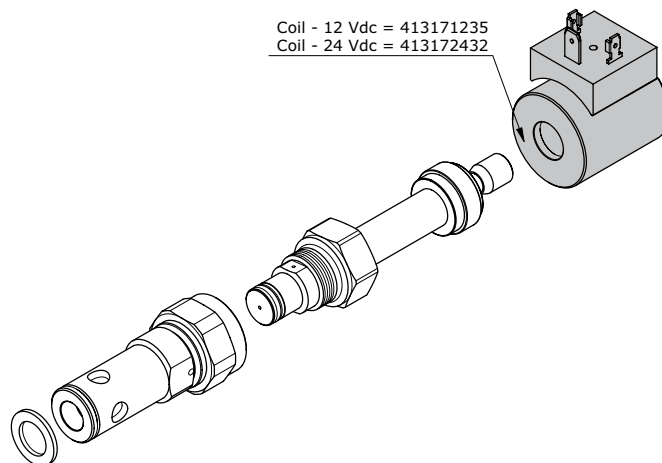

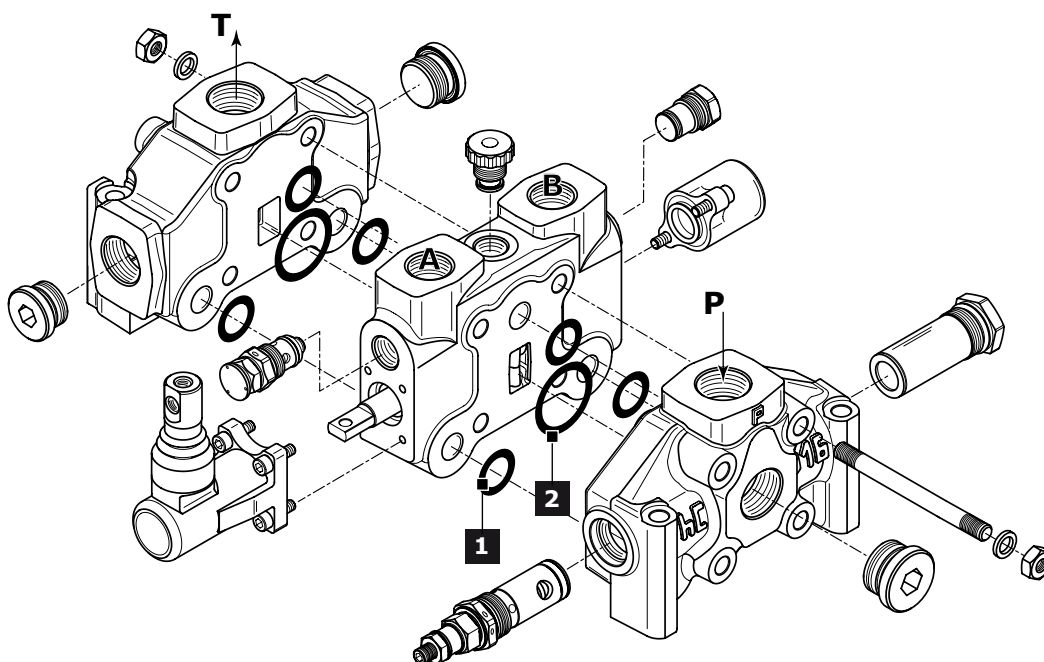

Outlet and work section			
Rif.	Order code	Description	Q.ty
1	412010609	O.R. 70SH 23,47 x 2,62 (2-119)	3
2	412010603	O.R. 70SH 39,34 x 2,62 (2-129)	1

**Complete Gasket kit: order code - 350945001**



**INSTALLATION AND MAINTENANCE**

**Guidelines**

- Mount the control valve securely to a flat surface (recommended 3 point fixing); at the time do not use a hammer to positioning by hitting.
- When handling the control valve, be careful not hold the pilot cover or return spring cap of the spool or accessory valves such as main relief valves and anti-shock relief valves.
- Clean piping materials sufficiently before use.
- Make sure to prevent the port openings from being entered with dust or foreign matters.
- Tighten the port connectors surely with the recommended fastening torques.
- Do not direct the jet of a pressure washing unit directly to the valve.

**Fittings tightening torque (Nm)**

thread type	port P	Port A - B	Port T
<b>BSP (ISO - 228)</b>	<b>G 3/4</b>	<b>G 3/4</b>	<b>G 3/4</b>
with rubber sealing (DIN 3869)	120	120	120
with copper or steel and rubber washer	120	120	120
<b>BSP (ISO - 228)</b>	<b>G 1</b>	<b>G 1</b>	<b>G 1</b>
with rubber sealing (DIN 3869)	150	150	150
with copper or steel and rubber washer	150	150	150
<b>UN-UNF (ISO - 725)</b>	<b>1"1/16 12 UNF</b>	<b>1"1/16 12 UNF</b>	<b>1"1/16 12 UNF</b>
with O.R.	120	120	120
<b>UN-UNF (ISO - 725)</b>	<b>1"5/16 12 UNF</b>	<b>1"5/16 12 UNF</b>	<b>1"5/16 12 UNF</b>
with O.R.	120	120	120



**Dimensions - Thread codes**

The connection ports size is indicated by an ordering code common for all Walvoil products. Following table shows all available connections.

**METRIC THREAD (ISO 9974-1)**

Type	M18x1,5	M22x1,5	M27x2
Code	<b>M01</b>	<b>M02</b>	<b>M03</b>

**BSP THREAD (ISO 1179-1)**

Type	1/4"	3/8"	1/2"	3/4"	1"	1 1/4"	1 1/2"	2"
Code	<b>G02</b>	<b>G03</b>	<b>G04</b>	<b>G05</b>	<b>G06</b>	<b>G07</b>	<b>G08</b>	<b>G09</b>

**UN / UNF THREAD (ISO 11926-1)**

Type	9/16" 18 UNF SAE6	3/4" 16 UNF SAE8	7/8" 14 UNF SAE10	1 1/16" 12 UNF SAE12	1 5/16" 12 UNF SAE16	1 5/8" 12 UNF SAE20
Code	<b>U02</b>	<b>U03</b>	<b>U04</b>	<b>U05</b>	<b>U06</b>	<b>U07</b>

**Dimensions - SAE Flange codes**

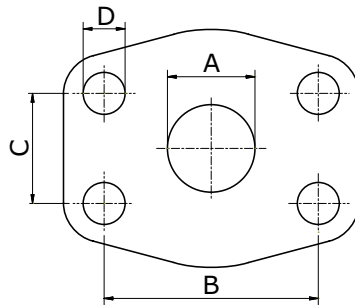

**SAE / 3000 FLANGE (ISO 6162-1)**

Type	3/4" (MA)	3/4" (UNC)	1" (MA)	1" (UNC)	1 1/4" (MA)	1 1/4" (UNC)	1 1/2" (MA)	1 1/2" (UNC)	2" (MA)	2" (UNC)	3" (MA)	3" (UNC)
Code	<b>S03</b>	<b>S04</b>	<b>S05</b>	<b>S06</b>	<b>S07</b>	<b>S08</b>	<b>S09</b>	<b>S10</b>	<b>S11</b>	<b>S12</b>	<b>S15</b>	<b>S16</b>
A	19	19	25	25	32	32	38	38	51	51	76	76
B	47,6	47,6	52,4	52,4	58,7	58,7	69,9	69,9	77,8	77,8	106,4	106,4
C	22,3	22,3	26,2	26,2	30,2	30,2	35,7	35,7	42,9	42,9	61,9	61,9
D	M10	3/8-16	M10	3/8-16	M10	7/16-14	M12	1/2-13	M12	1/2-13	M16	5/8-11

**SAE / 6000 FLANGE (ISO 6162-2)**

Type	3/4" (MA)	3/4" (UNC)	1" (MA)	1" (UNC)	1 1/4" (MA)	1 1/4" (UNC)	1 1/2" (MA)	1 1/2" (UNC)
Code	<b>S33</b>	<b>S34</b>	<b>S35</b>	<b>S36</b>	<b>S37</b>	<b>S38</b>	<b>S39</b>	<b>S40</b>
A	19	19	25	25	32	32	38	38
B	50,8	50,8	57,2	57,2	66,6	66,6	79,3	79,3
C	23,8	23,8	27,8	27,8	31,8	31,8	36,5	36,5
D	M10	3/8-16	M12	7/16-14	M14	1/2-13	M16	5/8-11



## GENERAL CONDITIONS AND PATENTS

### Introduction

These general conditions apply to all general supplies from Walvoil s.p.a., after receiving orders from the Customer. Should commercial terms such as EXW, DDP, etc be mentioned, of course the Incoterms of the International Chamber of Commerce must be referred to, according to the test existing when the general supply conditions are agreed on.

### Management of orders

No Customer's order is binding to Walvoil s.p.a. if Walvoil s.p.a. has not confirmed the order in writing. Walvoil s.p.a. commits to supplying the orders in compliance with the order confirmation that has been issued. Any disagreement with the content of the order confirmation must be communicated in writing to Walvoil s.p.a. within and no later than 5 days from the delivery of the order confirmation. The Customer commits to paying for the goods supplied by Walvoil s.p.a., according to the prices indicated on the order confirmation.

### Payment conditions

The Parties agree on the payment terms at the beginning of the supply. The terms will be indicated on the order confirmation. Should the Customer be late with the payments, Walvoil S.p.a. will be entitled to require the payment of interests on arrears based on the exiting Prime Rate increased by 2%. Should there be any payment delay, Walvoil s.p.a. will be entitled not to process the Customer's purchase order, even if it has already been confirmed.

### Delivery and shipment

The goods are always supplied Ex Works, even when Walvoil s.p.a. agrees with the Customer that the shipment, or a part of it, will be arranged by Walvoil s.p.a. It is agreed that the Customer will bear the risk of goods deterioration or damaging from the moment the goods are handed by Walvoil s.p.a. to the first carrier.

### Product characteristics

Walvoil s.p.a. commits to supplying good quality products, compliant with the technical specifications declared on the technical tables and on the catalogue. Walvoil s.p.a, even without notice, at its own discretion, reserves the right to modify the products as necessary, without these changes altering the main characteristics of the products.

### Claims

Any claims about defects on delivered products (just as an example: claims about the packaging, the number, the quantity or the external product characteristics) will have to be notified to Walvoil s.p.a. in writing, within and no later than 7 days from reception of the goods, otherwise the claims will be considered as null and void. Occult defects (the defects of the goods that cannot be spotted with a careful control of the goods received by the Customer), will have to be notified in writing to Walvoil s.p.a. within 7 days from the discovery of the defect, and anyhow no later than 12 months from the delivery of the goods, otherwise the claim will be considered as null and void. Even in case of claim or objection, the Customer will never be entitled to suspend or delay the payments to Walvoil s.p.a. for the products subject to claim or objection nor for any other supply.



**GENERAL CONDITIONS AND PATENTS**

**Warranty**

Should the products supplied by Walvoil not be compliant or have the required quality and should this defect be due to Walvoil, Walvoil s.p.a. commits, at its choice, to replace or repair the faulty products, as long as the defect or lack of compliance is notified to Walvoil s.p.a. in writing, as specified at point 6, within and no later than 18 months from product delivery. On the products that have been fixed or replaced in accordance with what specified above, the above-mentioned warranty applies. The 12 month duration starts from the date of repair or replacement. In case of defects, lack of quality or in case of lack of compliance for the supplied products, with the exception of fraud or serious offence, Walvoil s.p.a. only commits to repairing or replacing the faulty products, according to what specified above. This warranty replaces any other Supplier's warranty or liability established by the law. This warranty excludes any other liability contractual or extra-contractual by Walvoil s.p.a. on the products supplied by Walvoil (as a mere example: damage refund, loss of profit, product recall campaign, etc). Walvoil s.p.a. has signed a product civil liability police, with a suitable maximum coverage.

**Ownership retention**

The products supplied by Walvoil s.p.a. will be owned by the latter until Walvoil receives the complete payment for the supplied goods.

**Obligation confidentiality**

Walvoil s.p.a. commits to not disclosing the technical and commercial information it receives from the Customer, unless this information has already been publicly disclosed.

**Patents**

The Customer is not allowed to use the provided Products, or a part of them, their descriptions or drawings protected or not protected by Patent or registered trademark in order to design or make similar products, unless Walvoil s.p.a. previously issues its written authorization. Should Walvoil s.p.a. give its written authorization, all patents, trademarks, registered designs, copyrights and intellectual property rights related or connected to the Products provided by Walvoil s.p.a. will stay Walvoil's property. The Customer commits to respecting the highest confidentiality.

**Applicable law and court of jurisdiction**

Walvoil s.p.a.'s supplies are regulated by these General Supply Conditions and, for anything not defined here, by the Italian law. Any controversy related, generated or connected to the supply of Products by Walvoil s.p.a., where Walvoil s.p.a. is involved, will be exclusively dealt with by the Court of Bologna.



Walvoil worldwide

**WALVOIL S.P.A.**

DIREZIONE E COORDINAMENTO INTERPUMP GROUP S.P.A.  
Headquarters, Subsidiaries and Representative Offices

**Walvoil S.p.A. Headquarters**

Via Adige, 13/D . 42124 Reggio Emilia . Italy  
TEL. +39 0522 932411  
info@walvoil.com | www.walvoil.com

AUSTRALASIA

**Walvoil Fluid Power Australasia Pty Ltd**

13 Vanessa Way . Delahey VIC 3037 . Melbourne . Australia  
TEL. +61 458 918 750  
australasia@walvoil.com

BRAZIL

**Interpump Hydraulics Brasil Ltda | Walvoil Division**

Rua Gilberto de Zorzi, 525 . Bairro Forqueta 95115-730  
Caxias do Sul (RS)  
TEL. +55 54 3289 7000  
infobrasil@walvoil.com

CANADA

**Walvoil Canada Inc.**

3100, Rue Jacob Jordan . Terrebonne . Qc J6X 4J6 . Canada  
TEL. +1 450 477 1076 Ext:225  
info@walvoilcanada.com | www.walvoilcanada.com

CHINA

**Walvoil Fluid Power (Dongguan) Co. Ltd**

1st Floor, the Third Factory Area, Sijia, Shijie Town, Dongguan City  
Guangdong province. China.  
TEL. +86 769 81816189-8020  
info@walvoil.com.cn | www.walvoil.com.cn

SOUTH KOREA

**Walvoil Fluid Power Korea Ltd.**

(17818)80-15, Oseongsandan 1Ro, Oseong-myun, Pyeongtaek-si Gyeonggi-do  
Republic of Korea 451-872  
TEL. +82 31 682 6030  
info@walvoil.co.kr | www.walvoil.co.kr

FRANCE

**Walvoil Fluid Power France**

362 rue de Bretagne . Vritz . 44540 Vallons-de-l'Erdre  
TEL. +33 2 41 94 41 06  
france@walvoil.com

INDIA

**Walvoil Fluid Power (India) PVT. LTD.**

No. 1, 2nd Cross, 2nd Main, KIADB Industrial Area, Attibele, Anekal Taluk  
Bangalore - 562107 .  
TEL. +91 80 0614 24000  
info@walvoil.co.in | www.walvoil.co.in

U.S.A.

**Walvoil Fluid Power Corp.**

4111 North Garnett Tulsa, OK 74116, USA  
TEL. +1 918 858 7100  
info@walvoilusa.com | www.walvoilusa.com

**Walvoil Fluid Power Corp | Hydrocontrol Business Unit**

1109, Technology Drive . Red Wing . MN 55066 . U.S.A.  
TEL. +1 651 212 6400  
info@walvoilusa.com | www.walvoilusa.com

3<sup>rd</sup> edition Jan.2024

[www.walvoil.com](http://www.walvoil.com)



D1WHEB06E

