



DFE085

Solenoid control monoblock diverter valve for special applications

- 4 ways configuration
- Galvanized body designed for in-line mounting
- Specific design for steering applications
- Mechanical detent on working position

This catalogue shows technical specifications and diagrams measured with mineral oil of 46 mm²/s (46 cSt) viscosity at 40°C - (104°F) temperature.

WORKING CONDITIONS		
N. of available ways		4
Max. flow rating		25 l/min (6.6 US gpm)
Max. pressure		210 bar (3045 psi)
Available supply voltage	VDC	see reference page 108
Nominal power		38 W
Internal leakage A(B)⇒T	Δp = 100 bar (1450 psi)	7 cm ³ /min (0.42 in ³ /min)
Fluid		Mineral based oil
Fluid temperature	with NBR (BUNA-N) seals	from -20°C to 80°C (from -4°F to 176°F)
	with FPM (VITON) seals	from -20°C to 100°C (from -4°F to 212°F)
Viscosity	operating range	from 15 to 75 mm ² /s (from 15 to 75 cSt)
	min.	12 mm ² /s (12 cSt)
	max.	400 mm ² /s (400 cSt)
Max. level of contamination		20/18/15 - ISO 4406 - NAS 1638 - class 9
Ambient temperature for working conditions		from -40°C to 60°C (from -40°F to 140°F)

NOTE - For different working conditions please contact Sales Dept.

Available threads

PORTS THREAD	Available threads			
	BSP	UN-UNF	METRIC* (ISO 9974-1)	METRIC* (ISO 6149)
ALL PORTS				
DFE085	G 3/8	3/4-16 (SAE 8)	M16x1.5	M16x1.5

(*) Optional threads
for availability contact Sales
Department

Dimensional data and hydraulic circuit

4 ways

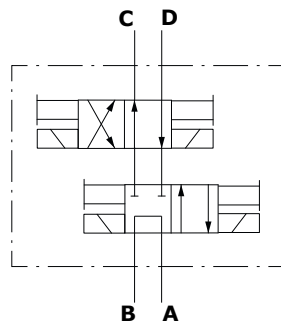
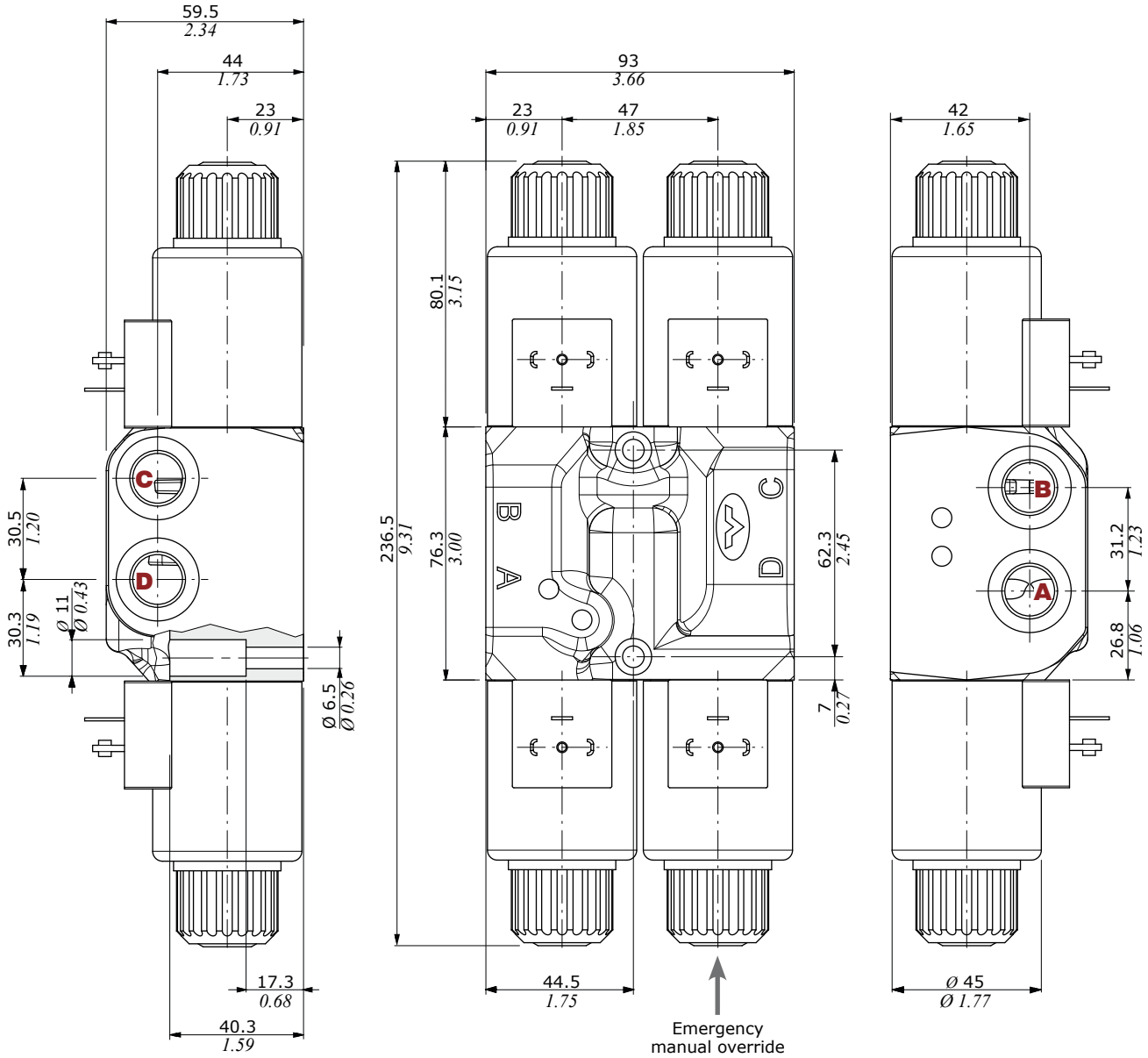

Performance data

Pressure drop versus flow :

"Crab" function

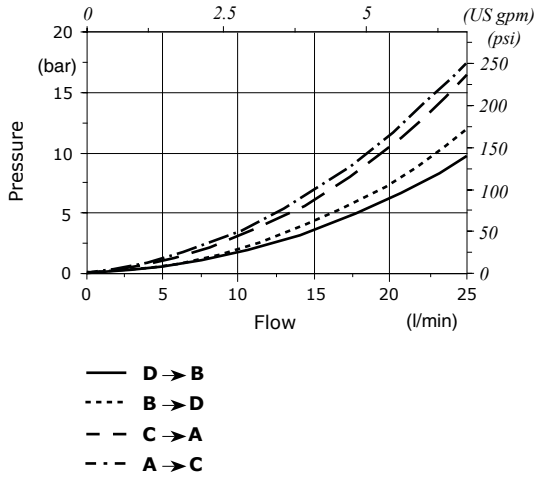

"Anterior" function

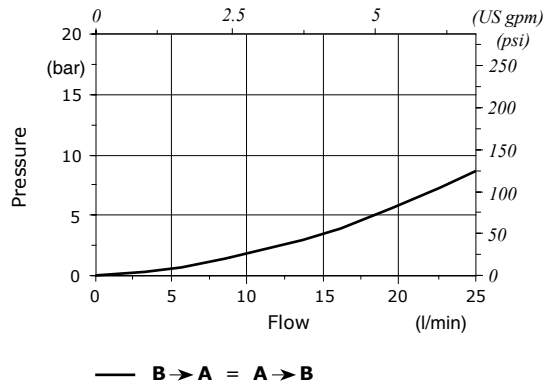

"Leading" function

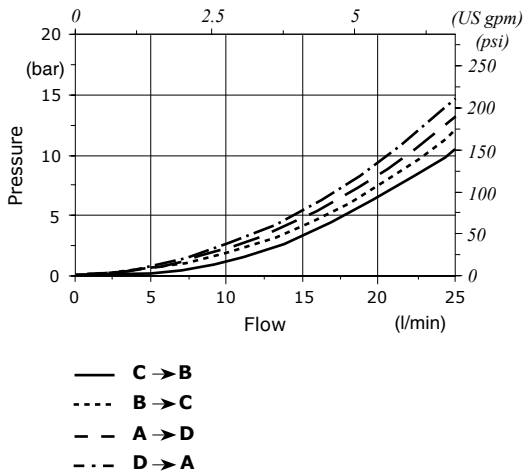

Minimum dynamic conditions

(Supply = Vn-10%, coil at 70 °C - 158 °F)

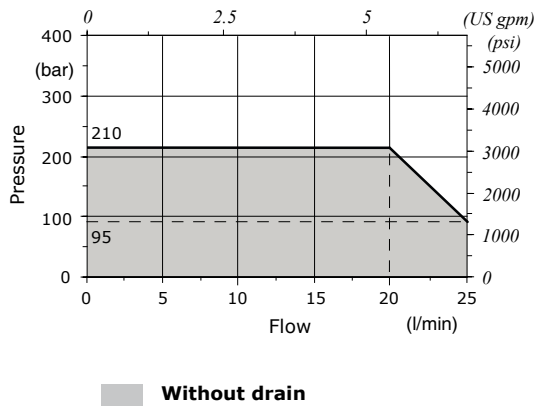

Part ordering codes

Example:

DFE085/4 BAB 01 16ES3 / BCD 01 16ES3 - 2 0 2 - 12VDC - ... - (CRZ)

1 2 3 2 3 4 5 5 Galvanized body

For description composition
see the text below

... 2 0 PD (300) DB 2 - 12VDC - ...

Coil voltage

Coil
1 = without coil
2 = with coil

Connection*
0 = ISO (Std)
2 = AMP-JPT
3 = Deutsch DT06
4 = Deutsch DT04-2P Male
5 = Deutsch DT04-4P Female
6 = Metri-Pack Female
7 = Metri-Pack Male
8 = WeatherPack Male
9 = WeatherPack Female

Connector orientation*
Std (omitted)
PD = connector perpendicular to coil axis
PL = connector parallel to coil axis

Diode*
(text omitted if diode is not present)
DB = bidirectional diode

Bellow
1 = without bellow
2 = with bellow

Length cables
(only if it's present)
Length is in mm/in

(*) - For diode and connector options
see coils table on page 108

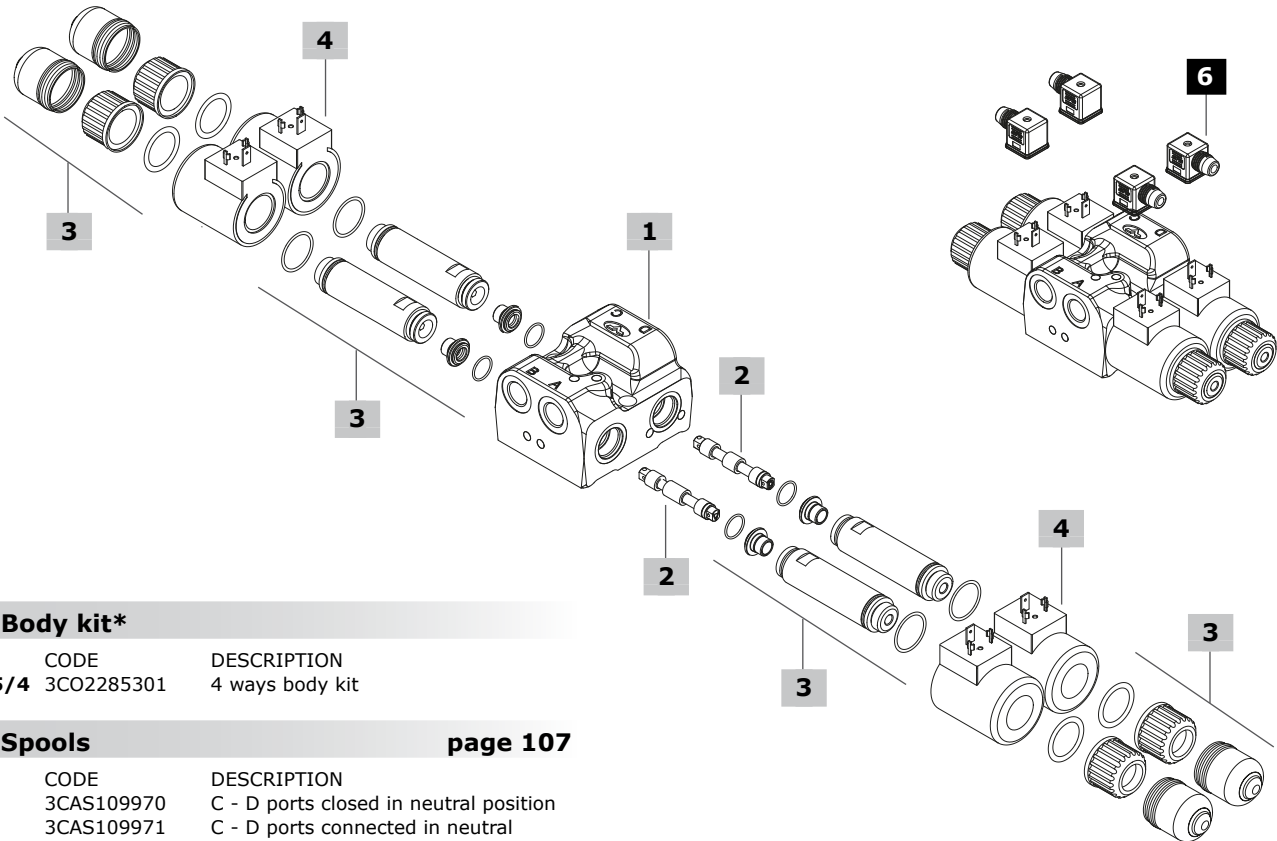

1 Body kit*		
TYPE	CODE	DESCRIPTION
DFE085/4	3C02285301	4 ways body kit

2 Spools page 107		
TYPE	CODE	DESCRIPTION
AB	3CAS109970	C - D ports closed in neutral position
CD	3CAS109971	C - D ports connected in neutral position

3 Complete controls page 107		
TYPE	CODE	DESCRIPTION
16ES3	5CAN160850	Spring return in pos. 2, without protective bellow
-	4ACC515	Optional assembly tube protective bellow

5 Body threading
Specify threading always when it is different from **BSP** standard

6 Accessories
For list of available connectors see pages 108

4 Coil
For list of available coils see pages 108

(*) - Codes are referred to **BSP** thread

Spool circuits

Type A-B

C - D ports closed
in neutral position

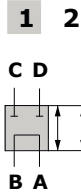

Spool stroke

Position 2: + 3 mm (0.11 in)

Type C-D

C - D ports connected
in neutral position

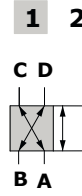

Spool stroke

Position 2: + 3 mm (0.11 in)

Complete controls

With spring return in position 2

Type 16ES3

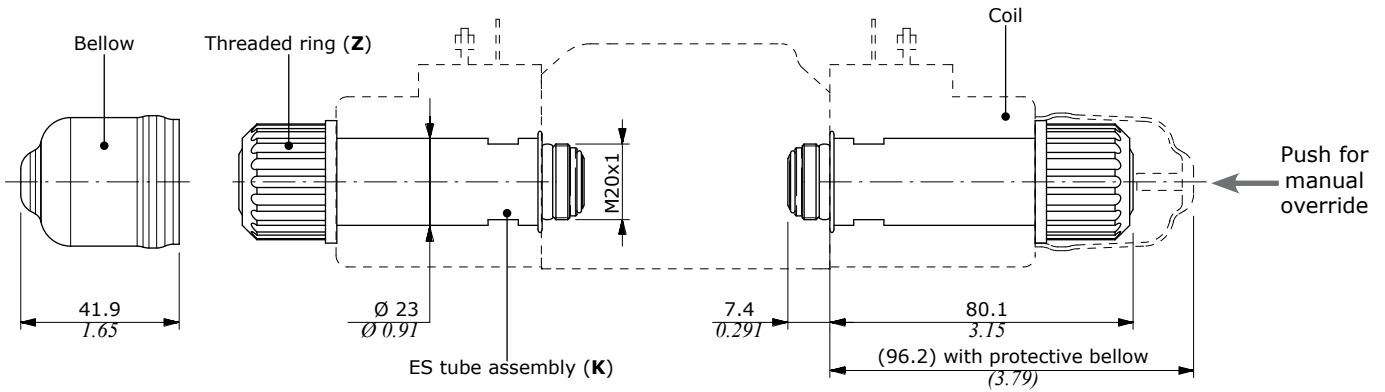
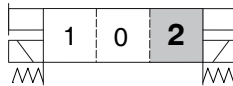

Wrenches and tightening torque

K = wrench 20 - 20 Nm (14.7 lbf^t)

Z = 24 Nm (17.7 lbf^t)

Coils and accessories

Type	Voltage	Ordering codes					Flying leads without connector
		ISO4400	Deutsch DT	AMP JPT	Packard Weatherpack	Packard Metri-pack	
D15	12 VDC	4SOL515012	4SOL515011 ⁽²⁾ 4SOL515014A ⁽³⁻⁶⁾	4SOL515016 ⁽⁵⁾	-	-	-
	14 VDC	-	4SOL515014B ⁽³⁻⁶⁾	4SOL515016A ⁽⁵⁾	-	-	-
	24 VDC	4SOL515024	4SOL515025A ⁽³⁻⁶⁾ 4SOL515021 ⁽²⁾	-	-	-	-
	48 VDC	4SOL515048	-	4SOL515049 ⁽²⁾	-	-	-
	98 VDC	4SOL515098	-	-	-	-	-
	110 VDC	4SOL515110	-	-	-	-	-
Mating connectors		4CN100995	5CON140031	5CON003	-	-	-

Notes: ⁽¹⁾ supply with AC and use only with rectifier connector - ⁽²⁾ with flying leads - ⁽³⁾ with bidirectional diode - ⁽⁴⁾ with unidirectional diode ⁽⁵⁾ integrated perpendicular type - ⁽⁶⁾ integrated parallel type

Features

Nominal voltage tolerance: ±10%

Nominal power.....: 38 W

12/14/24/48/98/110 VDC

Nominal current.....: 3.16 A @ 12 VDC

: 2.9 A @ 14 VDC

: 1.58 A @ 24 VDC

: 0.79 A @ 48 VDC

: 0.41 A @ 98 VDC

: 0.35 A @ 110 VDC

Insulation.....: Class H (180°C - 356°F)

Weather protection.....: IP65 - ISO4400

: IP69K - Deutsch DT

: IP65 - AMP JPT

Insertion.....: 100%

ISO4400 connector

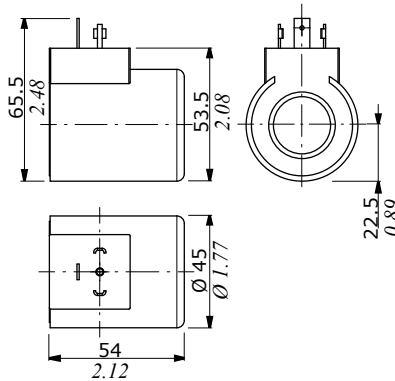

Flying leads with DEUTSCH DT04 connector

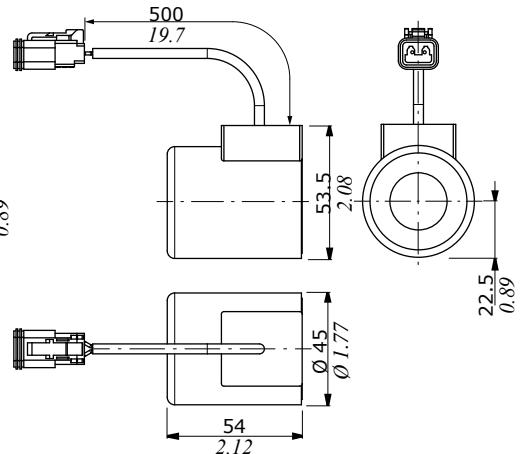

DEUTSCH DT04 connector

(Parallel type)

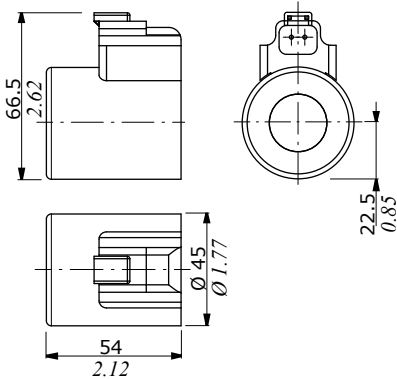

AMP JPT connector

(Perpendicular type)

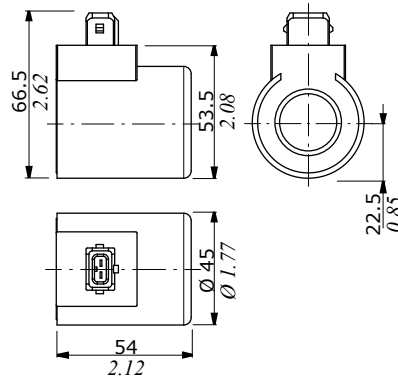

Flying leads with AMP JPT connector

