



SE..A type sequence valves - 3 way

- Direct acting
- External pilot
- Poppet type
- From SAE08 to SAE10 cavities

Technical specifications and diagrams are measured with mineral oil of 46 cSt viscosity at 40°C (104°F) temperature.

	SE08A	SE10A
Nominal flow	5 l/min (1.32 US gpm)	20 l/min (5.3 US gpm)
Max. pressure	210 bar (3050 psi)	
Oil leakage	80% of max. pressure setting	0.25 cm ³ /min (0.015 in ³ /min)
Fluid	mineral based oil	
Viscosity	10-200 cSt	
Max level of contamination	20/18/14 ISO4406	
Fluid temperature	with NBR seals with FPM seals	from -20°C (-4°F) to 80°C (176°F) from -20°C (-4°F) to 100°C (212°F)
Environmental temp. for working conditions	from -20°C (-4°F) to 50°C (122°F)	
Cavity	SAE 08/3	SAE 10/3
Weight	0.28 kg (0.62 lb)	0.47 kg (1.04 lb)

NOTE - For different conditions, please contact Walvoil Sales Dpt.

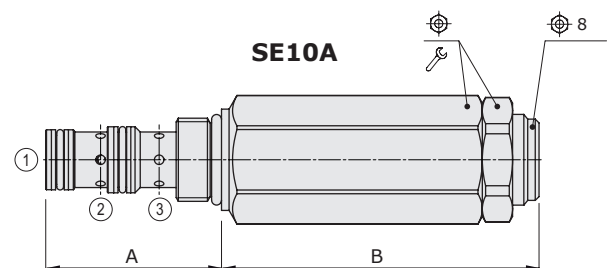
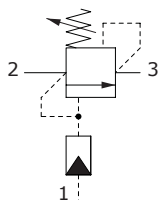

Valve type	A		B		⌀	Nm	lbft
	mm	in	mm	in			
SE08A	41	1.61	69	2.72	27	30	22
SE10A	47	1.85	95	3.74	30	50	37

Ordering codes and description composition

SE08A/1S1B

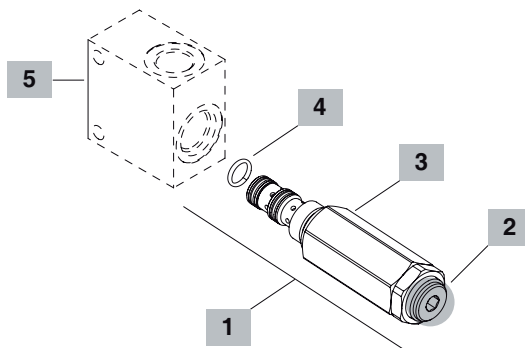
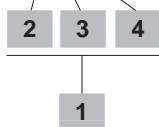

1 Cartridges

TYPE	CODE	DESCRIPTION
SAE cavity 08/3		
SE08A/1S1B	OSE08002003	With pressure range 1
SE08A/1S2B	OSE08002002	With pressure range 2
SE08A/1S3B	OSE08002001	With pressure range 3
SE08A/1S4B	OSE08002000	With pressure range 4
SAE cavity 10/3		
SE10A/1S1B	OSE10002001	With pressure range 1
SE10A/1S2B	OSE10002002	With pressure range 2
SE10A/1S3B	OSE10002000	With pressure range 3
SE10A/1S4B	OSE10002003	With pressure range 4

2 Adjustments

TYPE	DESCRIPTION
S	Screw

3 Pressure settings

Standard setting is referred to at 1 l/min (0.26 US gpm) flow

TYPE	DESCRIPTION
1	Range 5÷50 bar (72.5÷725 psi); Std. setting 30 bar (435 psi)
2	Range 20÷100 bar (290÷1450 psi); Std. setting 50 bar (725 psi)
3	Range 50÷150 bar (725÷2175 psi); Std. setting 100 bar (1450 psi)
4	Range 100÷250 bar (1450÷3600 psi); Std. setting 180 bar (2600 psi)

4 Seals

TYPE	DESCRIPTION
B	NBR (Buna) o-ring seals, std configuration
V	FPM (Viton) o-ring seals, contact Sales Dept.

5 Valve body

TYPE	CODE	DESCRIPTION
SAE 08/3-G 1/4	3CC0830B11	Aluminium body for cavity 08 valve, G 1/4 std thread
SAE 10/3-G 3/8	3CC1030C11	Aluminium body for cavity 10 valve, G 3/8 std thread

For steel bodies or different threading see from page 217

Rating diagrams

SE08A pressure drop vs. flow 2->3

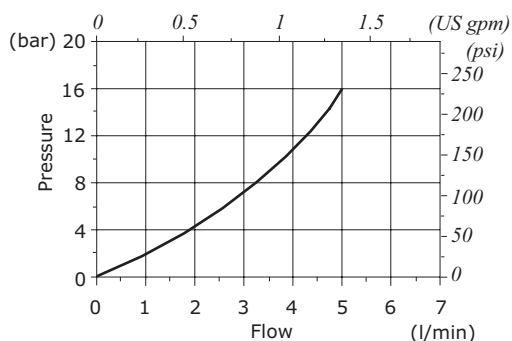

SE10A pressure drop vs. flow 2->3

