



## CED252 electronic control unit

- 12VDC applications
- "Dead man" switch management
- Float function management
- Two proportional function controls (3 inputs / 4 outputs)
- Five digital outputs controls
- Designed for front-end loader applications
- Available with ISOBUS (ISO-11783) standard

### Working conditions

#### General features

#### CED252

Supply voltage	from 9 to 16 V
Current consumption	> 100 mA
Max. current output	21 A - 12 VDC
Interface	RS232, 9600, 8, n, 1 - CAN 2.0 A - B, 125-250 Kbit/sec
EMC compatibility	200 V/m - ISO13766, ISO14982, 2000/2/EC, CE
Environmental compatibility	IEC60068-2-6/27/29
Working temperature	from -40 to +85°C ( <i>from -40°F to 185°F</i> )
Protection degree	IP67
Weight	0.8 Kg ( <i>1.8 lb</i> )

#### Analog inputs

Number	up to 11
Signal type	up to 6, from 0 to 30 VDC - up to 5, from 0 to 5 VDC

#### Digital inputs

Number	1
Signal type	from 0 to 30 VDC

#### Proportional outputs

Number	5 x HSD
Signal type	PWM - (HSD*)
Frequency	100-150-220 Hz
Max. load	5 x 2A

#### ON/OFF outputs

Number	5 x HSD*
Signal type	0/VB
Max. load	5 A

NOTE (\*): HSD - High Side Driver

# Electronic control units

## CED252 electronic control unit

### Dimensions and pin-out

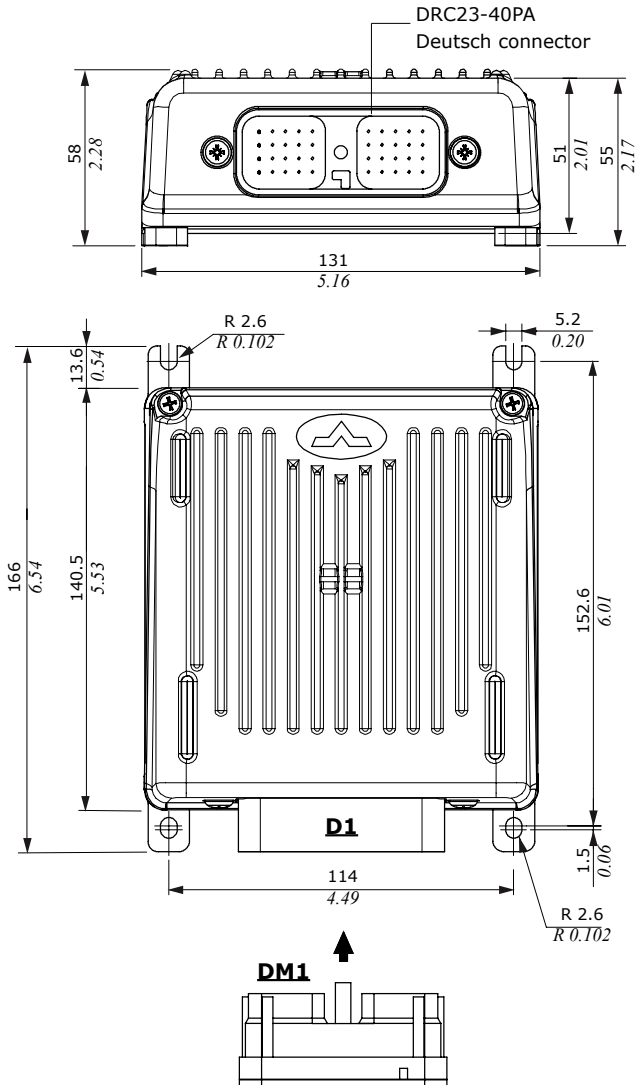

### D1 connector

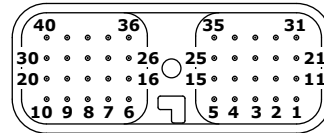

### D connector PIN-OUT

Pin	function	Pin	function	Pin	function	Pin	function
1	OUT_8	11	OUT_7	21	OUT_10	31	OUT_6
2	OUT_9	12	OUT_1	22	OUT_2	32	OUT_3
3	VK+	13	GND_1	23	OUT_5	33	OUT_4
4	VK+	14	VK+	24	GND_2	34	VJ+
5	GND_3	15	VB+	25	VEM+	35	VS+
6	VB-	16	VJ-	26	AI_11	36	AI_1
7	AI_3	17	AI_2	27	AI_8	37	AI_5
8	AI_6	18	AI_7	28	AI_4	38	AI_9
9	AI_10	19	GND	29	RX	39	TX
10	VS-	20	CAN_SH	30	CAN_H	40	CAN_L

### Mating connectors

Name	Type
DM1	DRC26-40SA Deutsch

### CED252 control unit code

Code	183350025
Protocol	SAE J1939
Description	CED252/PHC251C/v4015
Notes	Supply voltage 12V, 2 prop. function (4 outputs - 2A), 3 ON-OFF outputs (5A)

### CED252 control unit code, ISOBUS certification

Code	183350030
Protocol	ISOBUS
Description	CED252/ISOBUS/LOADER/v4033.02
Notes	Supply voltage from 9 to 16V, 5 x HSD* proportional outputs (2A), 5 x HSD* ON-OFF outputs (5A)

NOTE (\*): HSD - High Side Driver

### System diagram

Standard circuit configuration for 183350025.

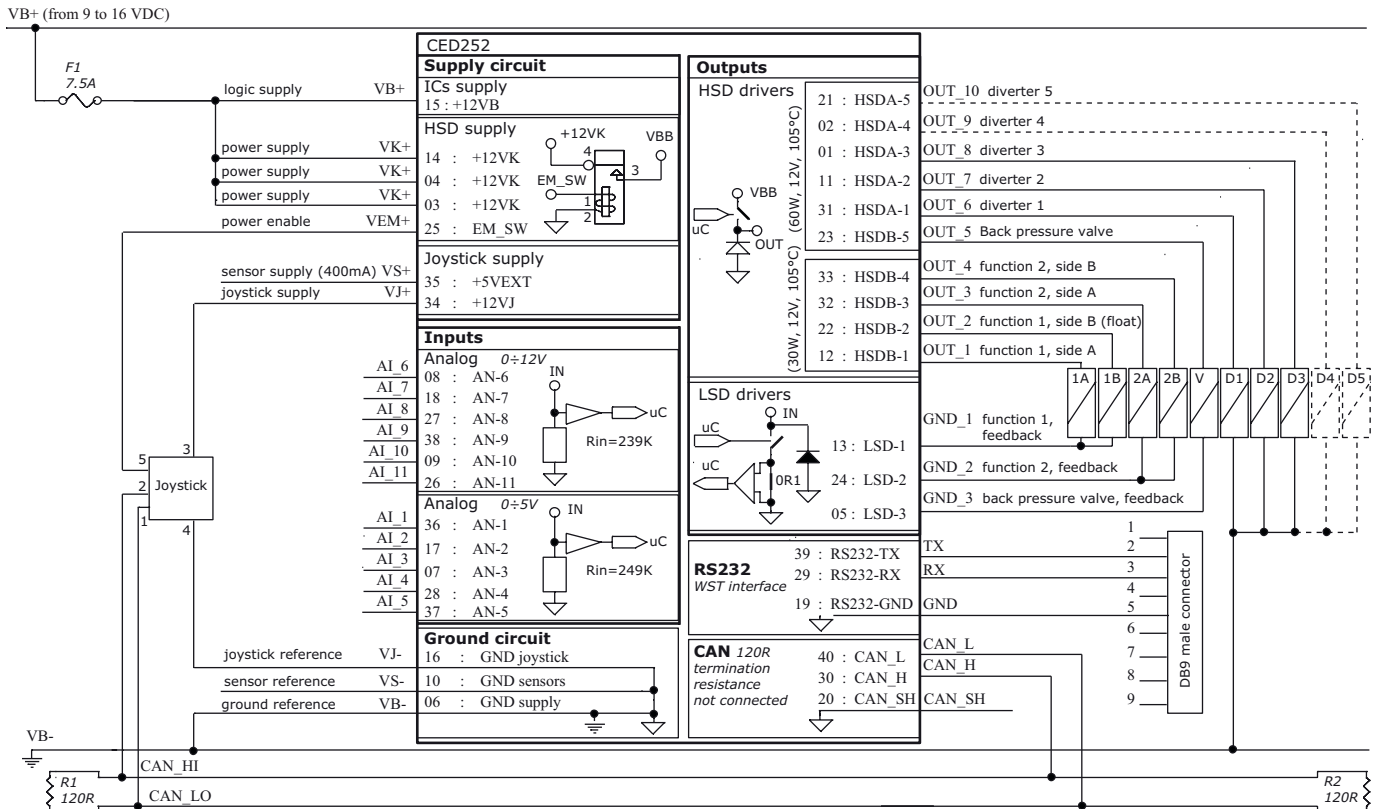

# Electronic control units

## CED252 electronic control unit

### System diagram

#### ISOBUS circuit configuration for 183350030

The CED252 electronic control unit is compatible with the Universal Terminal UT (release 2.0) and it is already available on the AEF Database (Agricultural Industry Electronics Foundation).

The CED252 electronic control unit is configured for:

- 3 proportional inputs, Type 3, Analog – return to 50%, Negative/Positive
- 10 on/off inputs Type 2, Non Latching (momentary), Increase value
- 3 pairs proportional outputs, PWM control, with current compensation,
- 6 power 60W outputs, ON/OFF control.

This high number of inputs and outputs makes this unit the ideal controller of any professional Front Loader, implementing the most common and automatic functionalities requested by the application. Thanks to its construction, the unit can be mounted outside of the tractor cabine, directly on the Front Loader attachment.

Being ISOBUS compatible makes it easy to interface the control of the complete loader to the joystick already available inside the tractor cabine, and, eventually, adapt the human-machine interface to the preferences and the characteristics of the operator, reducing his physical and cognitive fatigue. The CED252 electronic control unit can be interfaced to the CJW ISOBUS joystick (see page 14 and 18).

