



MONOBLOCK
DIRECTIONAL CONTROL VALVE

S
LM080



 **walvoil**
HYDRAULIC CONTROL SYSTEMS

Features

Simple, compact and heavy duty designed monoblock valves from 1 to 6 sections for open and closed center hydraulic systems.

H Fitted with a main pressure relief valve and a load check valve.

H Available with parallel or tandem circuit.

H Optional power beyond port.

H Diameter 14 mm - 0.55 in interchangeable spools.

H Available manual, with microswitches and remote with flexible cables spool control kits.

Additional information

This catalog shows the product in the most standard configurations.

Please contact Customer Service Dpt. for more detailed information or special request.

WARNING!

All specifications of this catalog refer to the standard product at this date.

Walvoil, oriented to a continuous improvement, reserves the right to discontinue, modify or revise the specifications, without notice.

WALVOIL IS NOT RESPONSIBLE FOR ANY DAMAGE CAUSED BY AN
INCORRECT USE OF THE PRODUCT.

5th edition December 2000:

This edition supercedes all prior documents.

Contents

Working conditions	4
Dimensional data	5
Hydraulic circuit	6
Performance data	7
Ordering codes	8
Inlet relief options	10
Spool options	11
"A" side spool positioners	16
"B" side options	20
Inlet and outlet port options	23
Installation and maintenance	24

SDM080

Working conditions

This catalog shows technical specifications and diagrams measured with mineral oil of 46 mm²/s - 46 cSt viscosity at 40°C - 104°F temperature.

Nominal flow rating		25 l/min	6.6 US gpm
Operating pressure (maximum)		315 bar	4600 psi
Max. back pressure	on outlet port T	25 bar	360 psi
Internal leakage A(B)→T	$\Delta p=100 \text{ bar} - 1450 \text{ psi}$ fluid and valve at 40°C - 104°F	3 cm ³ /min	0.18 in ³ /min
Fluid		Mineral oil	
Fluid temperature range	with NBR (BUNA-N) seals	from -20° to 80°C	from -4° to 176°F
	with FPM (VITON) seals	from -20° to 100°C	from -4° to 212°F
Viscosity	operating range	from 15 to 75 mm ² /s	from 15 to 75 cSt
	min.	12 mm ² /s	12 cSt
	max.	400 mm ² /s	400 cSt
Max level of contamination		19/16 - ISO 4406	NAS 1638 - class 10
Ambient temperature range		from -40° to 60°C	from -40° to 140°F

NOTE - For different conditions please contact Customer Service.

Valve type **WALVOIL**
SDM080/2
 Production batch : **P0000001**
 P00 = production year (2000)
 00001 = progressive number
100820001
 Valve code **MADE IN ITALY**

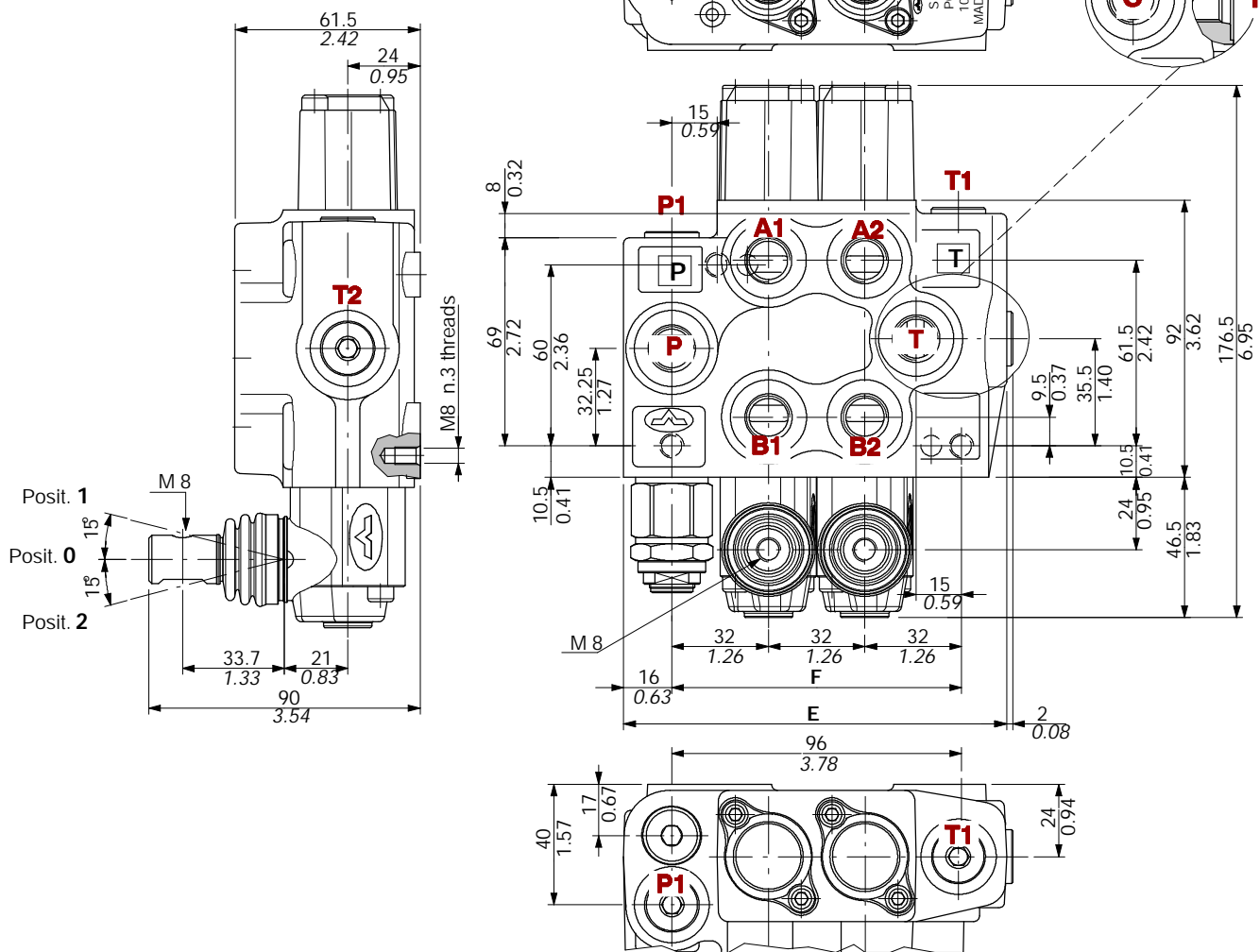

TYPE	E		F		Weight	
	mm	in	mm	in	kg	lb
SDM080/1-P	95	3.74	64	2.52	2.5	5.5
SDM080/2-P	127	5.00	96	3.78	3.5	7.7
SDM080/3-P	159	6.26	128	5.04	4.5	9.9

TYPE	E		F		Weight	
	mm	in	mm	in	kg	lb
SDM080/4-P	191	7.52	160	6.30	5.5	12.2
SDM080/5-P	223	8.78	192	7.56	6.5	14.3
SDM080/6-P	255	10.04	224	8.82	7.5	16.5

Standard threads

PORT	BSP (ISO 228/1)	UN-UNF (ISO 11926-1)	METRIC (ISO 6149-1)
Inlet P and power beyond C	G 3/8		M18x1.5
A and B ports	G 1/4	9/16-18 UNF-2B (SAE 6)	M14x1.5
Outlet T	G 3/8		M18x1.5

Hydraulic circuit

Standard execution with left inlet in relation to the lever pivot box and top inlet and outlet ports (**PSA** configuration).

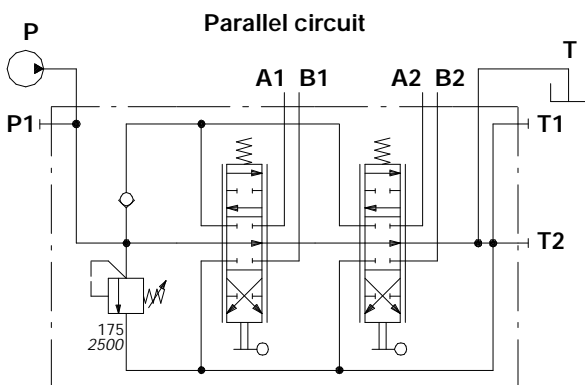
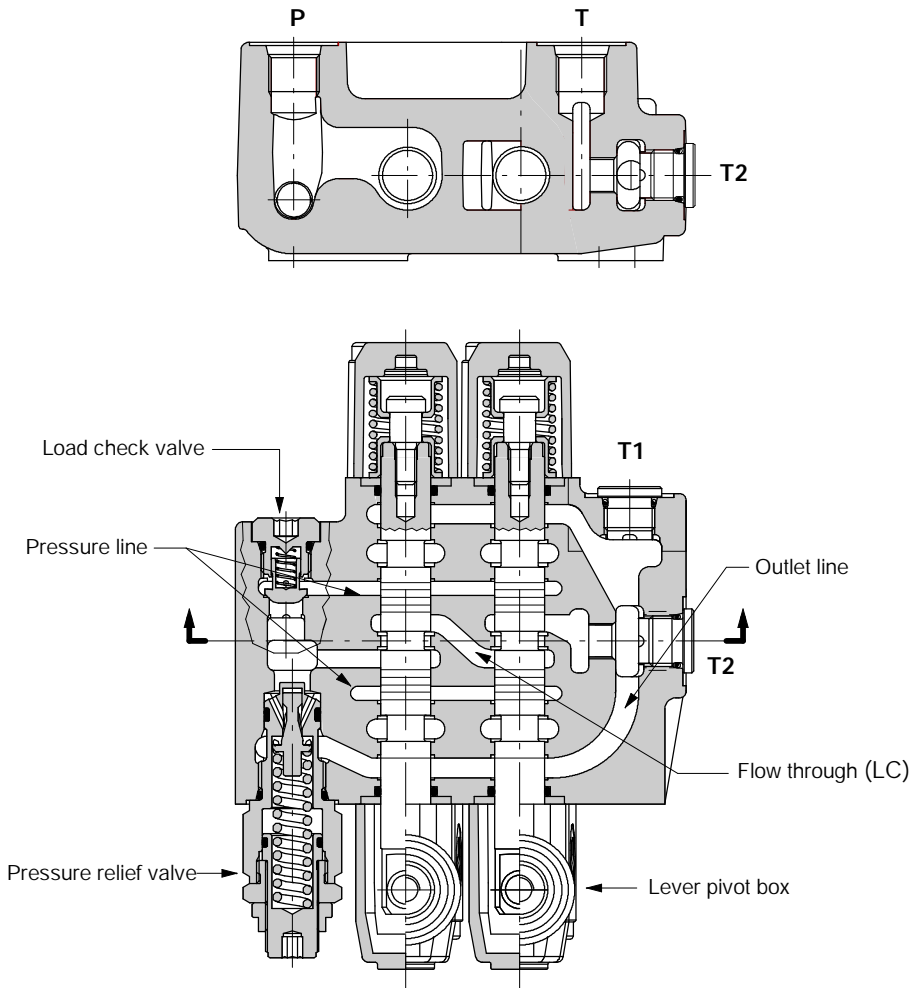

Ex.: SDM080/2-P(TG3-175)/18L/18L/PSA

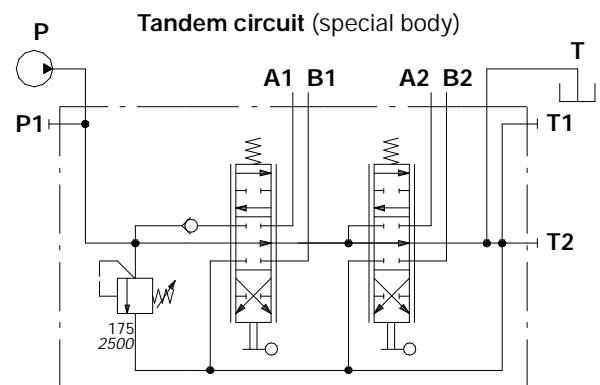

Ex.: SDM080/2-SP1(TG3-175)/18L/18L/PSA

NOTE - A simmetrical body allows the reverse assembly of spools and relative control kits (right inlet ED).

Performance data (pressure drop vs. flow)

Open center

From upper inlet to upper outlet (PSA configuration).

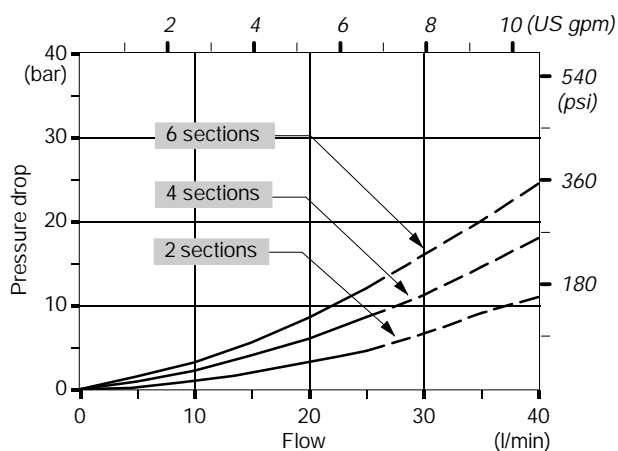
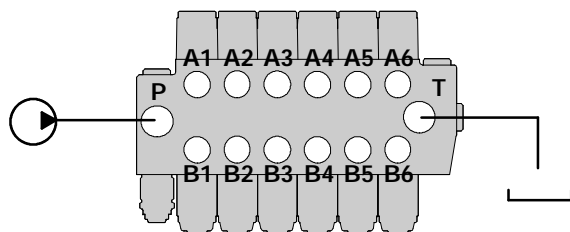

Inlet to work port

From upper inlet to A port (spool in position 1) or B port (spool in position 2).

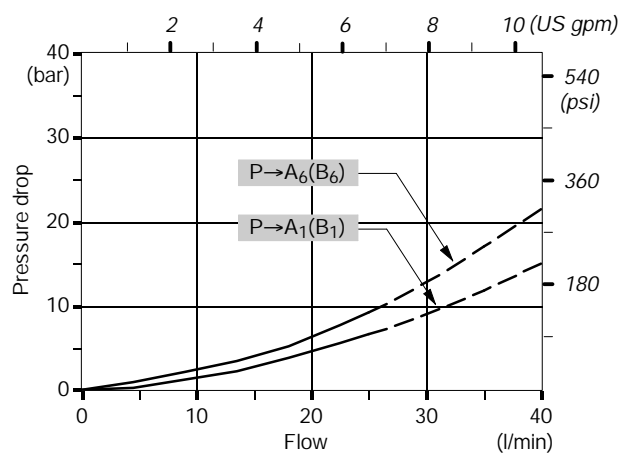
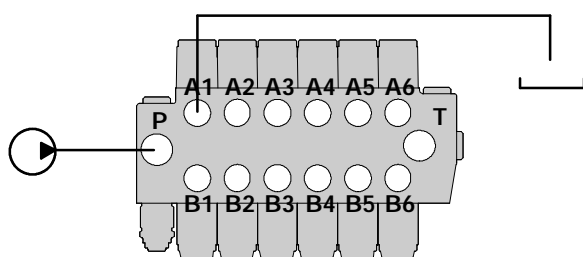

Work port to outlet

From A port (spool in position 2) or B port (spool in position 1) to upper outlet

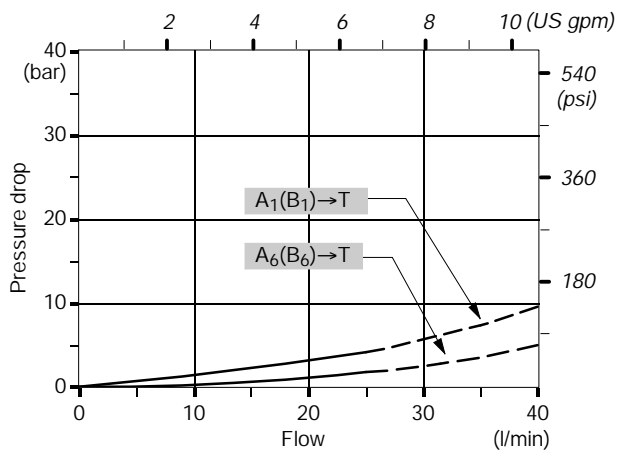
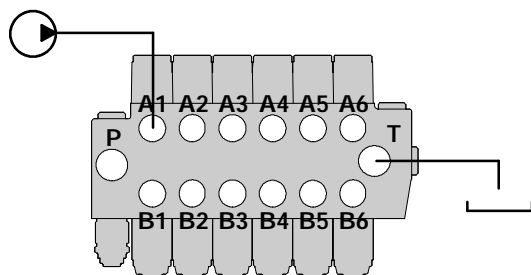

NOTE - Measured with spool type 1.

SDM080

Ordering codes

Example:

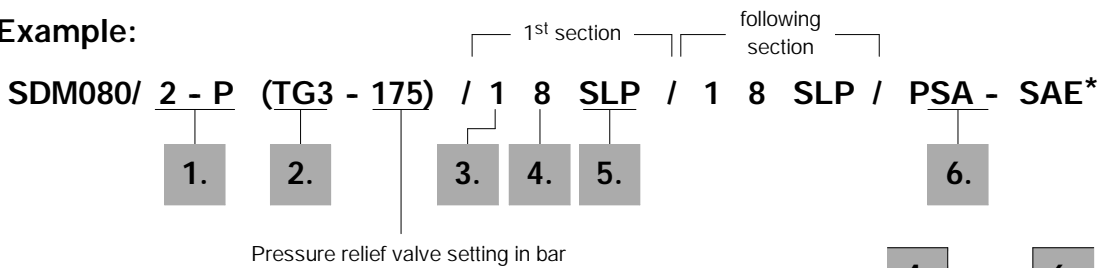

1. Body kit *

TYPE	CODE	DESCRIPTION
1-P	5KC5117000	Parallel 1 section
2-P	5KC5127000	Parallel 2 sections
3-P	5KC5137000	Parallel 3 sections
4-P	5KC5147000	Parallel 4 sections
5-P	5KC5157000	Parallel 5 sections
6-P	5KC5167000	Parallel 6 sections

Include body, seals and load check valve.

2. Inlet relief options

page 10

TYPE	CODE	DESCRIPTION
<u>VMD080 direct pressure relief valve type T</u>		
(TG2-80)	X162121080	Range 63 to 125 bar / 900 to 1800 psi standard setting 80 bar / 1150 psi
(TG3-175)	X162121175	Range 100 to 200 bar / 1450 to 2900 psi standard setting 175 bar / 2500 psi
(TG4-250)	X162121250	Range 160 to 250 bar / 2300 to 3600 psi standard setting 250 bar / 3600 psi

Standard setting is referred to 10 l/min - 2.6 US gpm flow.

SV	XTAP524340	Relief valve blanking plug
----	------------	----------------------------

3. Spool options

page 11

TYPE	CODE	CIRCUIT DESCRIPTION
1	3CU1010130	Double acting, 3 positions, with A and B closed in neutral position
1CS	3CU1010200	Double acting, 3 positions, with A and B closed in neutral position, for flow up to 12 l/min - 3.17 US gpm
1PA(55)BH	3CU1011100	Double acting, 3 positions, with anti-shock valve on port A (set to 55 bar / 800 psi)
1PB(190)	3CU1011200	Double acting, 3 positions, with anti-shock valve on port B (set to 190 bar / 2760 psi)
2CS	3CU1025130	Double acting, 3 positions, with A and B open to tank in neutral position
3CS	3CU1031130	Single acting on A, 3 positions, B plugged; needs SAE 6 plug (see part I)

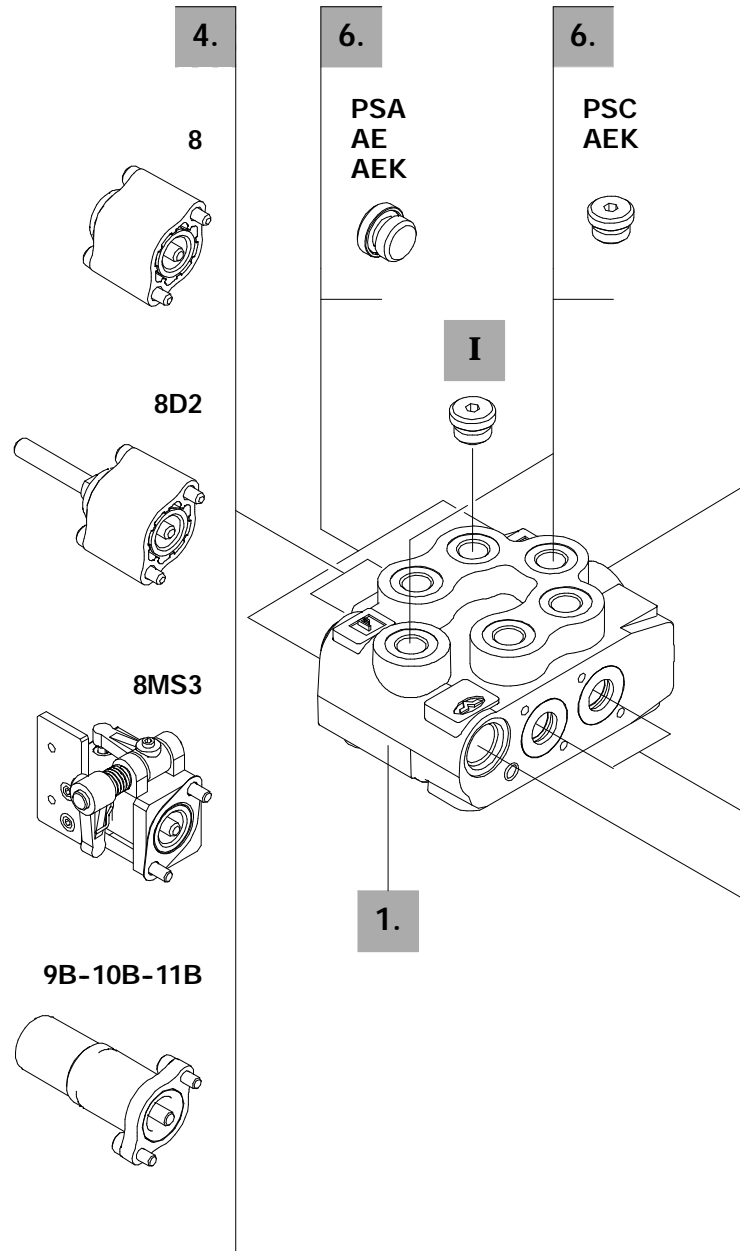

4. "A" side spool positioners *page 16*

TYPE	CODE	DESCRIPTION
8	5V08102000	With spring return in neutral position
8D	5V08102200	With spring return in neutral position and extension pin with M6 female thread for dual control
8D2	5V08102220	With spring return in neutral position and extension pin with M8 thread for dual control
8MS3	5V08102553	With spring return in neutral position, operation in position 1 and 2, prearranged for centralized microswitch control
9B	5V09202010	With detent in position 1 and spring return in neutral position
10B	5V10202010	With detent in position 2 and spring return in neutral position
11	5V11102000	With detent in positions neutral, 1 and 2
11B	5V11202010	With detent in positions 1 and 2, spring return in neutral position

5. "B" side options *page 20*

TYPE	CODE	DESCRIPTION
L	5LEV102010	Standard lever box
SLP	5COP102000	Without lever, with dust-proof plate
TQ	5TEL102100	Cable connection
LCB	5CLO102000	Mechanical joystick

6. Inlet and outlet port options * *page 23*

TYPE	CODE	DESCRIPTION
PSA	3XTAP817130	Upper inlet and outlet (n.3 SAE 6 plugs required)
PSC	3XTAP817130	Cap side inlet and outlet (n.3 SAE 6 plugs required)
AE	4TAP310007 3XTAP817130	M10x1 plug for power beyond (n.2 SAE 6 plugs required)
AEK	4TAP310007 3XTAP817130	M10x1 for closed center circuit (n.3 SAE 6 plugs required)

I Ports plug *

TYPE	CODE	DESCRIPTION
SAE 6	3XTAP817130	For single acting spool type 3

II Optional hand levers

TYPE	CODE	DESCRIPTION
AL01/M8x120	170011012	For L lever box L = 120 mm / 4.72 in
AL08/M12x150	170013115	For LCB joystick L = 150 mm / 5.91 in

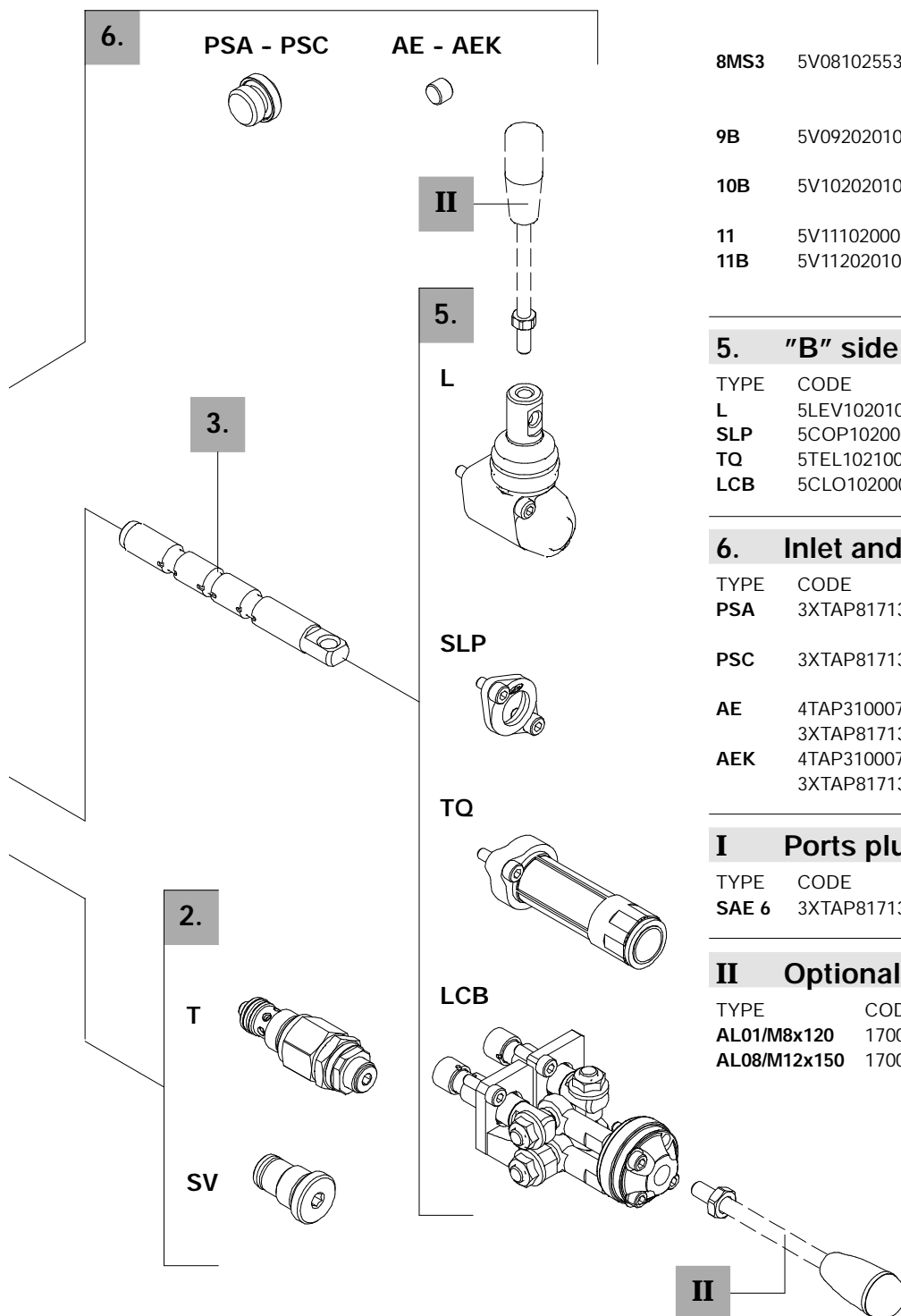
NOTE (*) - Items are referred to **UN-UNF** thread.

SDM080

Inlet relief options

Pressure relief valve

VMD080 (T G 3 - 175)

- Pressure setting in bar (standard 175 bar - 2500 psi).
- Adjustable spring type (2, 3, 4).
- Adjustment type (G, Z).

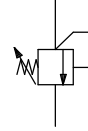

Adjustment type

G: with screw

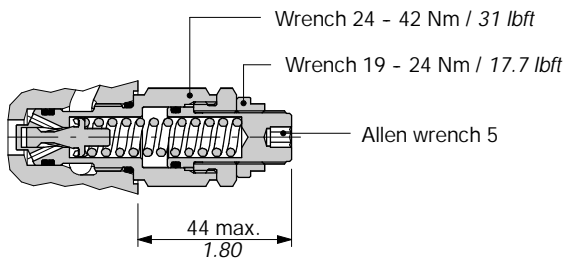

Z: with iron tamper proof cap

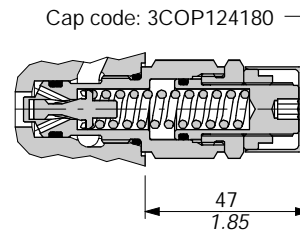

Performance data

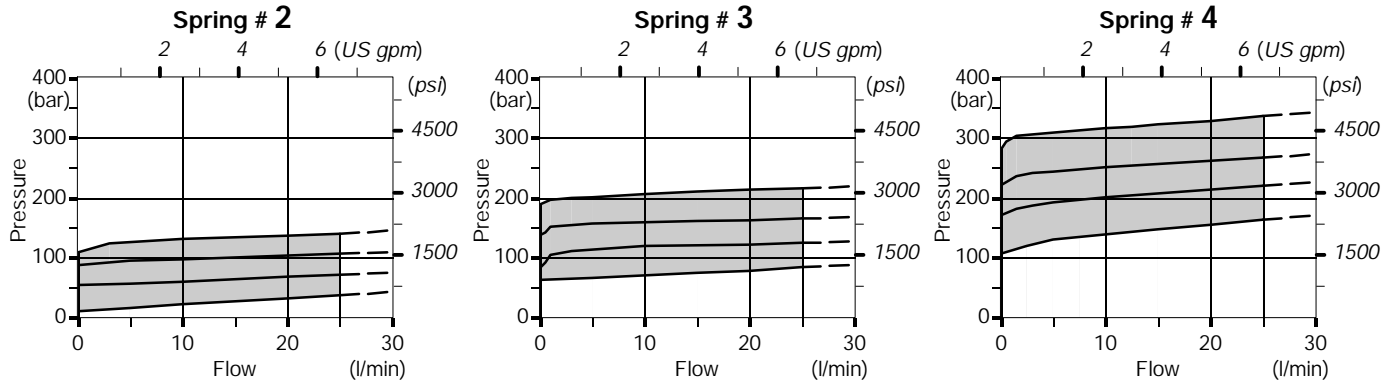

SV: relief valve blanking plug

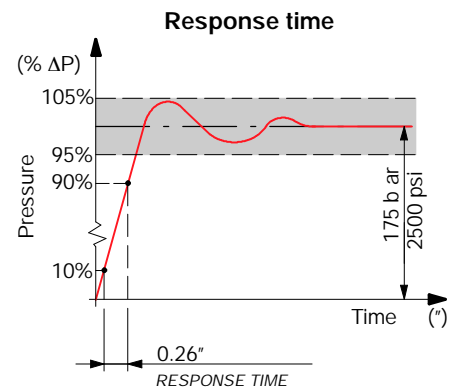
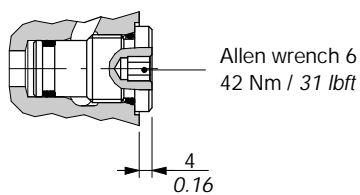

Type 1

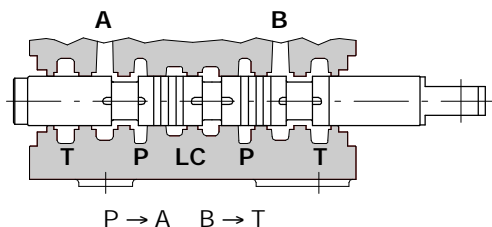

" stroke = + 5,5mm
+ 0.22 in

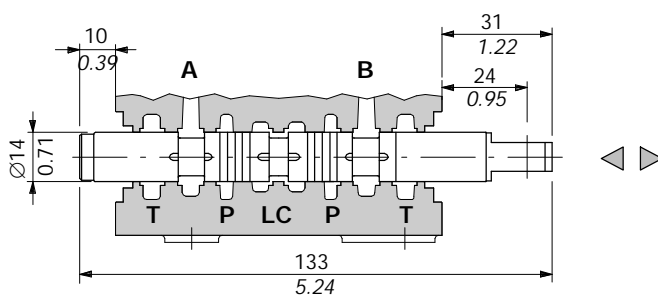
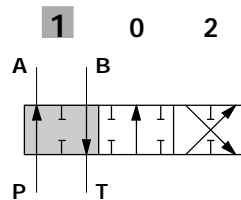

P-A-B-T closed, with flow through line (LC) open

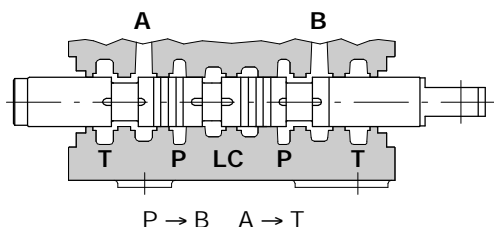
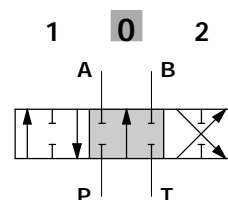

A stroke = - 5,5mm
- 0.22 in

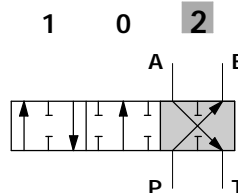

Performance data

Spool metering P → A(B)

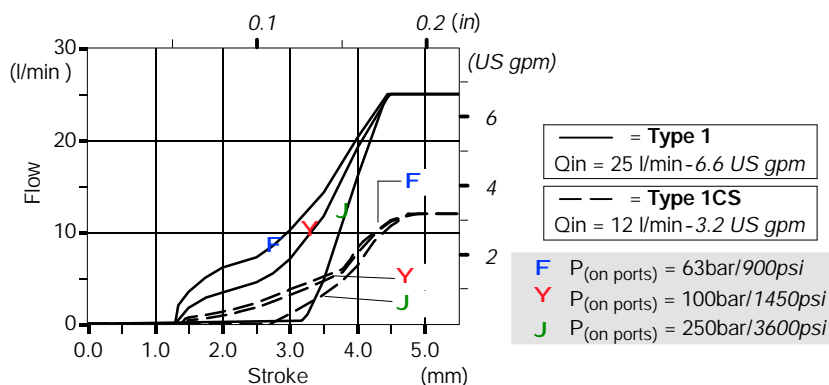

Spool metering A(B) → T

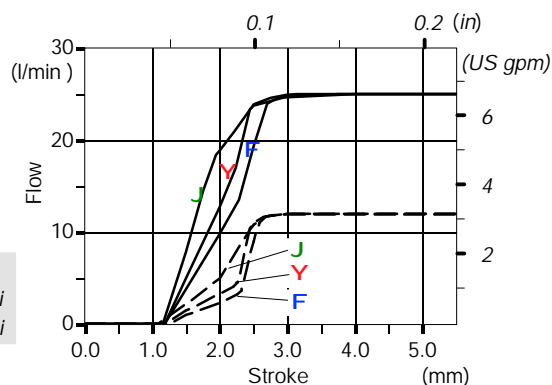

SDM080

Spool options

Type 1PA(55)BH

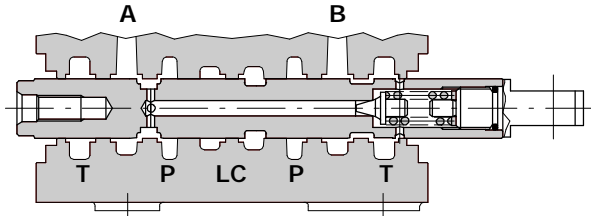

P → A B → T

stroke = + 5.5mm
+ 0.22 in

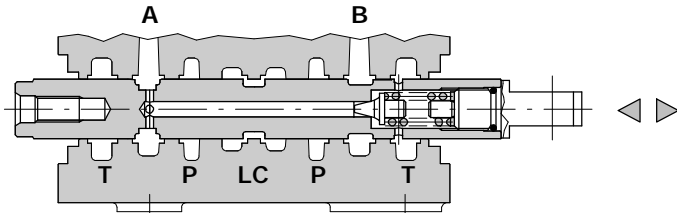
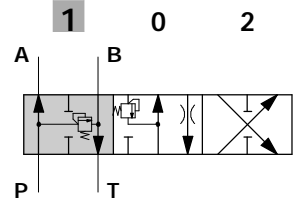

P-A closed, B partially open to T

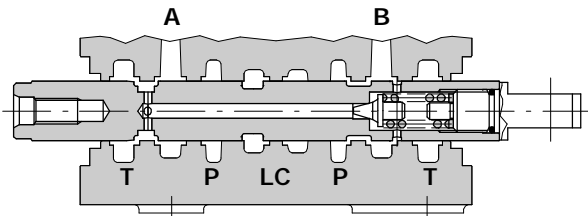
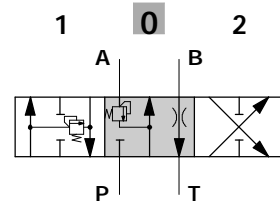

P → B A → T

stroke = - 5.5mm
- 0.22 in

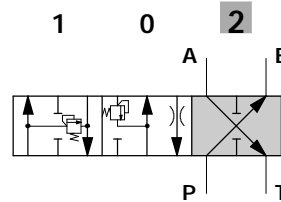

Performance data

Pressure-flow diagram

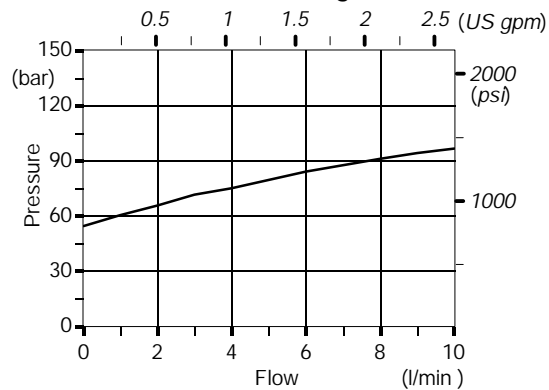

Type 1PB(190)

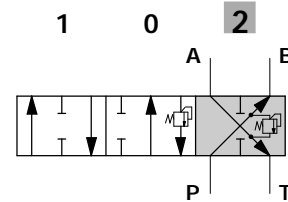
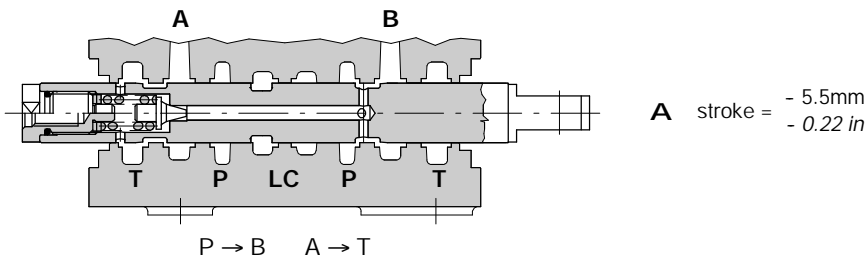
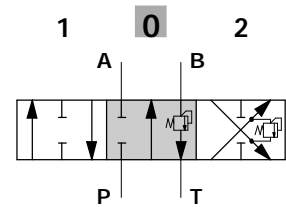
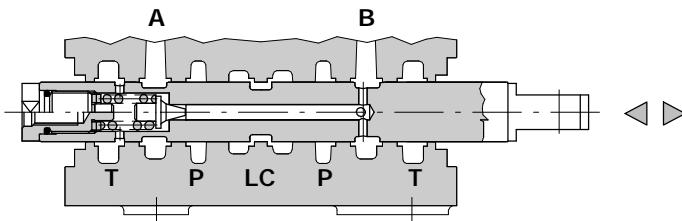
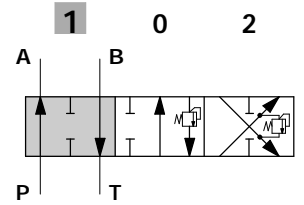
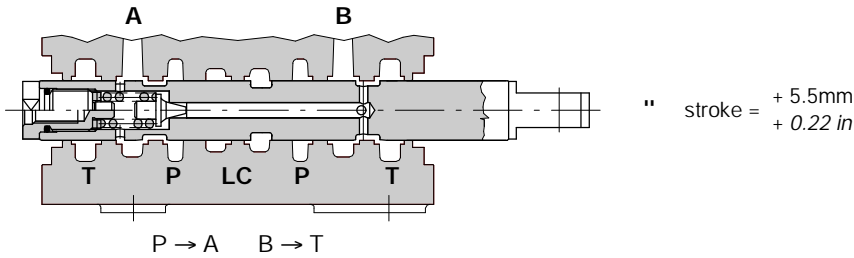

Performance data

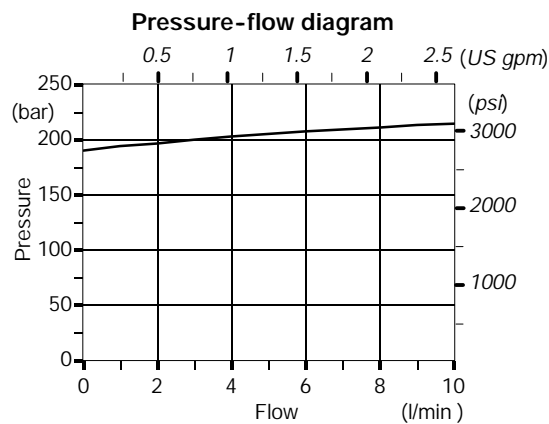

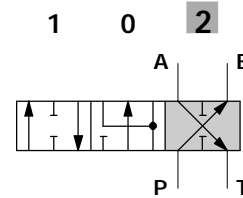
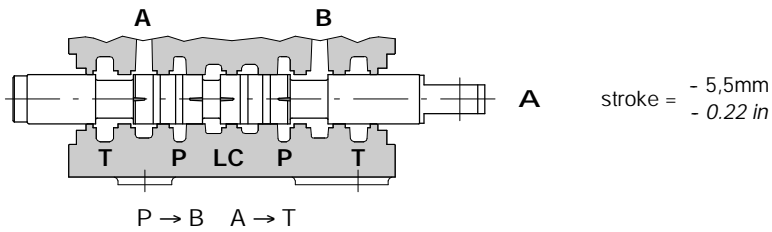
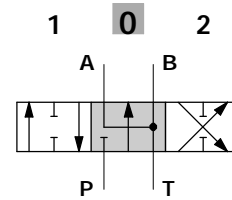
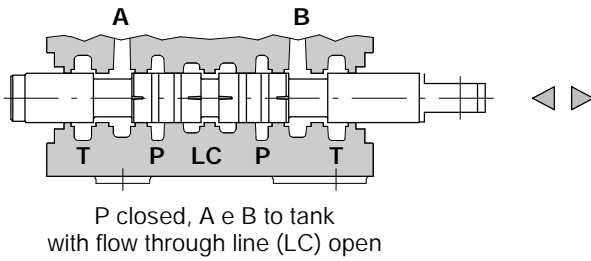
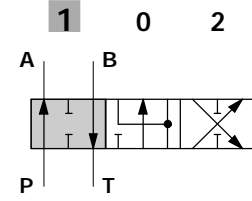
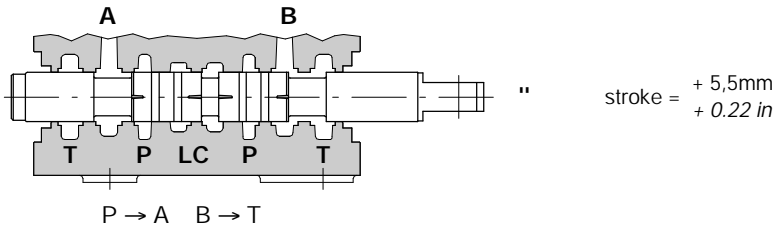

Performance data

Spool metering P→A(B)

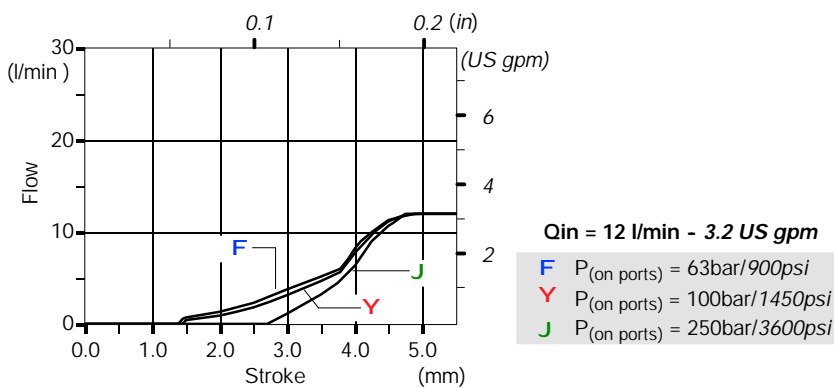

Type 3CS

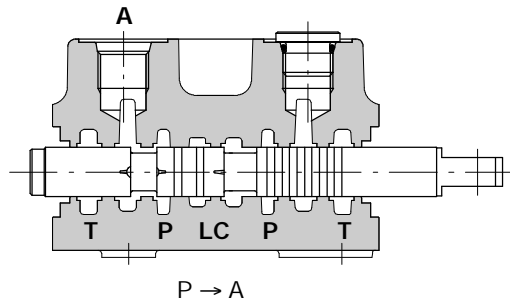

stroke = + 5,5mm
+ 0.22 in

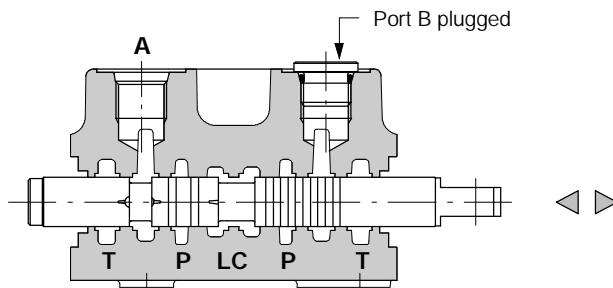
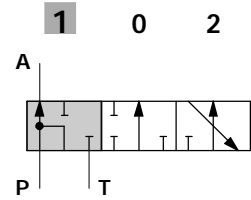

P-A-T closed, with flow through line (LC) open

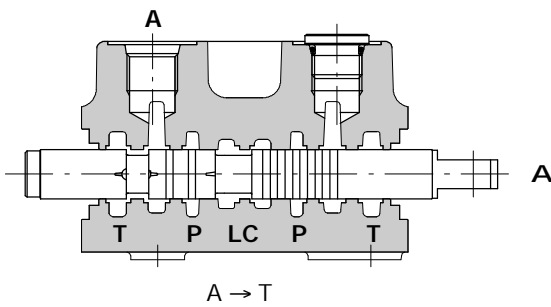
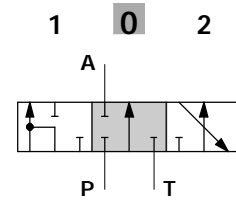

stroke = - 5,5mm
- 0.22 in

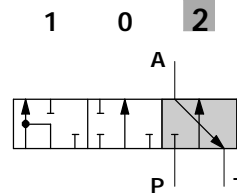

Performance data

Spool metering P to A

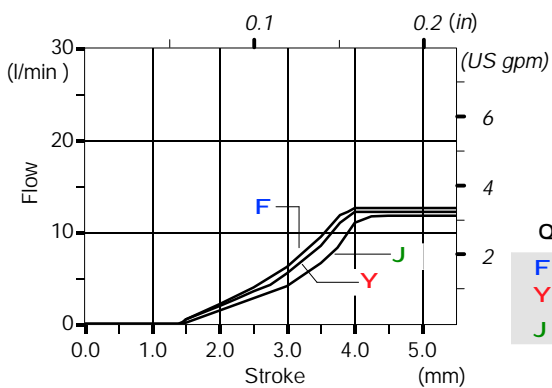

Q_{in} = 12 l/min - 3.2 US gpm

- F P_(on ports) = 63bar/900psi
- Y P_(on ports) = 100bar/1450psi
- J P_(on ports) = 250bar/3600psi

Spool metering A to T

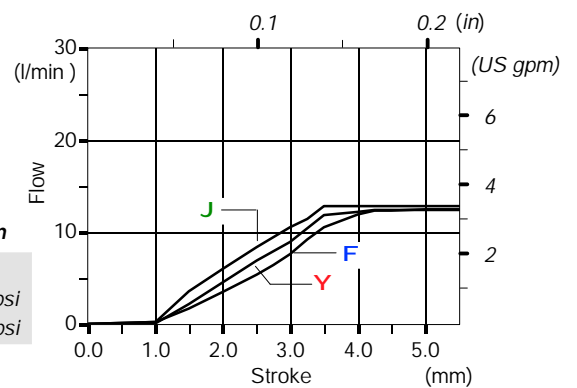

SDM080

"A" side spool positioners

With spring return

8 kit

Supplied with standard spring type B (see force-stroke diagram).

Available with lighter spring type A (8MA code: 5V08302000) or heavier type C (8MC code: 5V08202000).

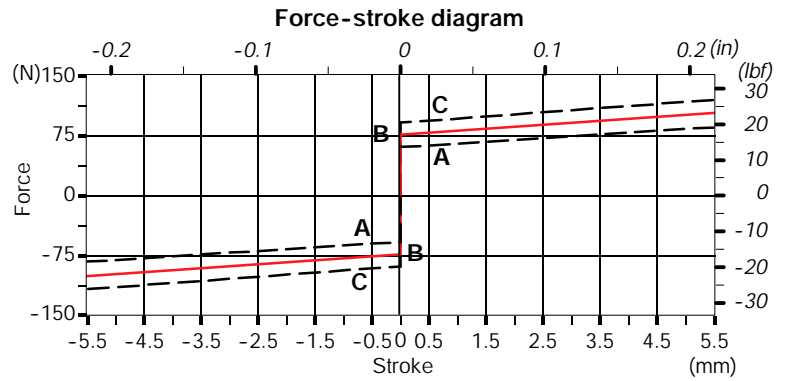
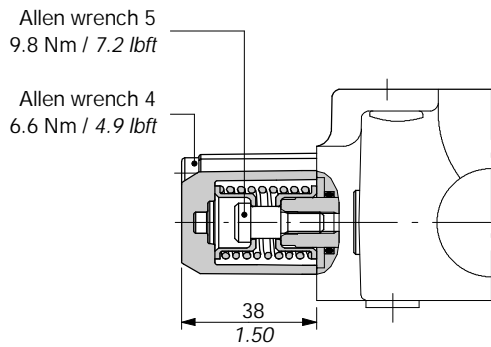

8D-8D2 kits for dual control

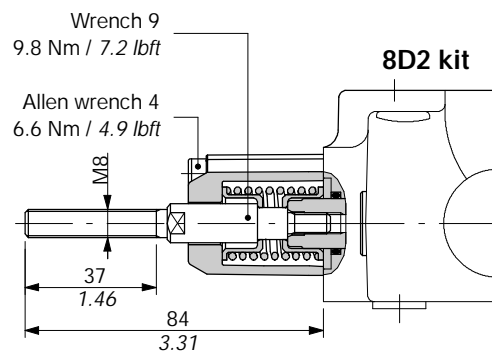
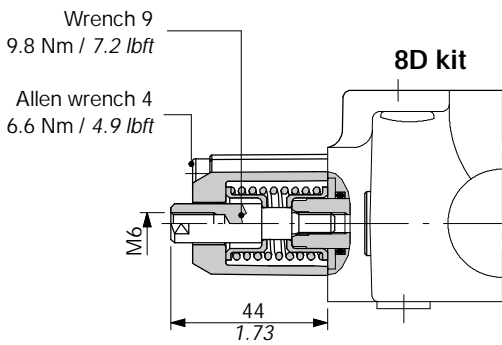
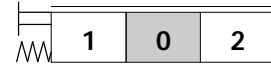

With detent

9B kit

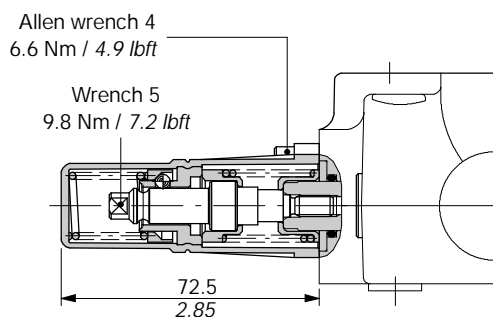

Operating features

Unlocking force : 200 N / 45 lbf ±10%

10B kit

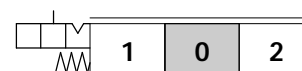
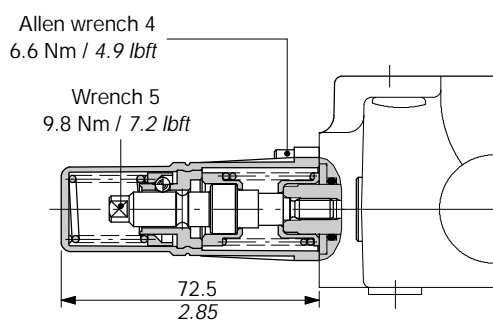

Operating features

Unlocking force : 200 N / 45 lbf ±10%

11 kit

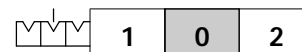
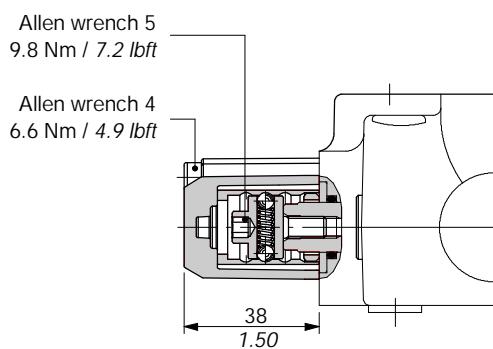

Operating features

Locking force : 100 N / 22.5 lbf ±10%

Unlocking force : 100 N / 22.5 lbf ±10%

11B kit

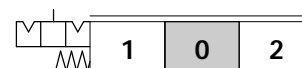
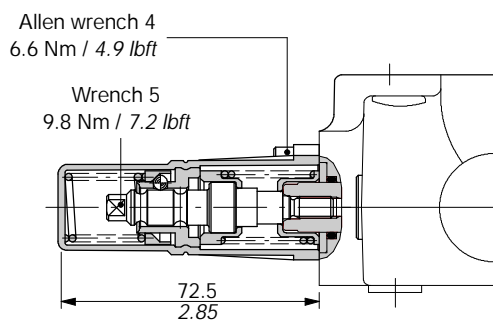

Operating features

Unlocking force : 200 N / 45 lbf ±10%

"A" side spool positioners

8MS3 kit: with centralized microswitch control

Example of a two section valve assembly

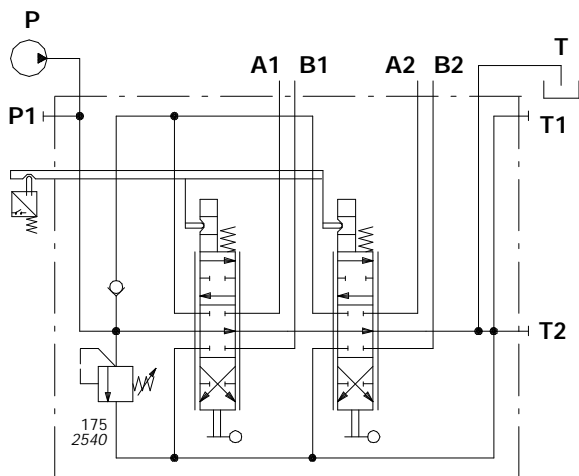
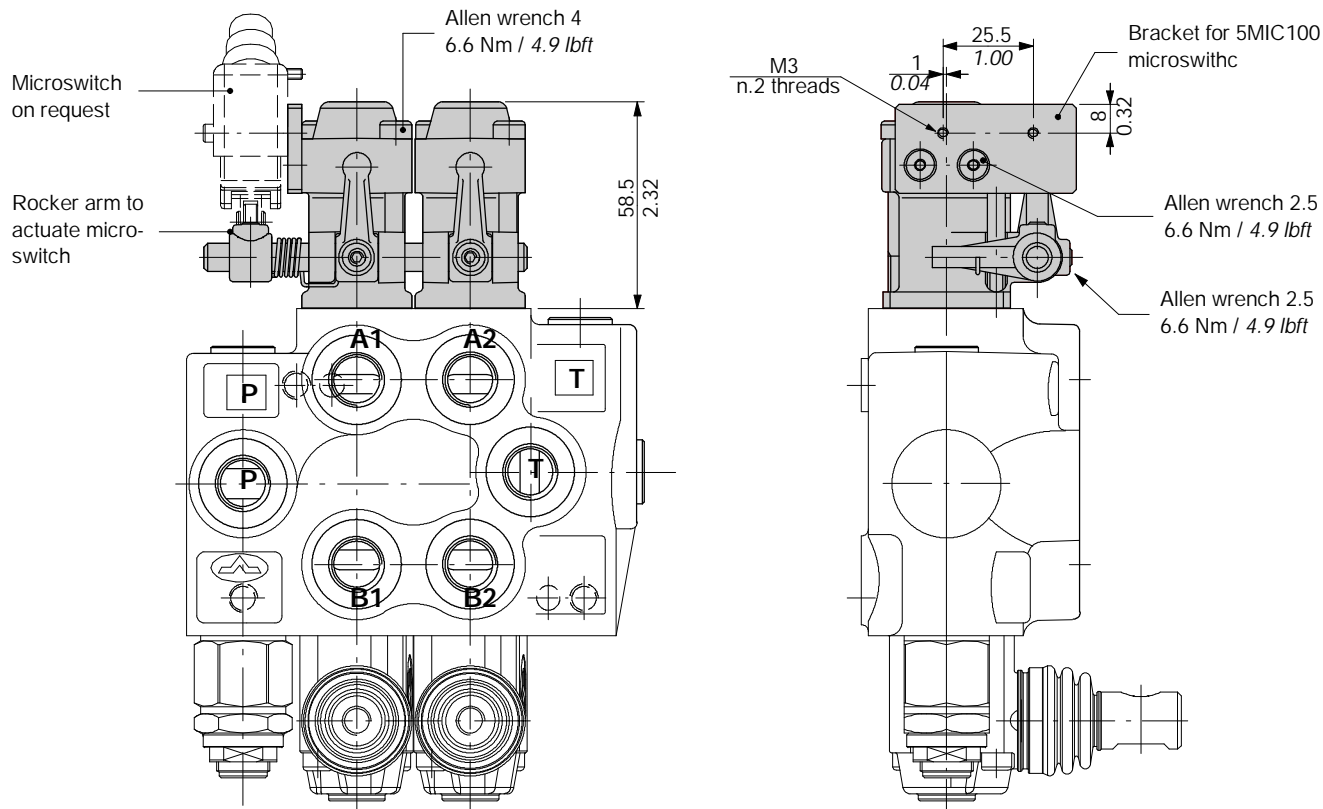

Ex.: SDM080/2-P(TG3-175)/18MS3L/18MS3L/PSA-SAE - **KM 2 S 51**

Assembling kit ——— 51 = with bracket for IP51 microswitch fixing
 67 = with bracket for IP67 microswitch fixing
 Nr. of working sections ——— S = bracket placed on left
 D = bracket placed on right

8MS3 kit: with centralized microswitch control

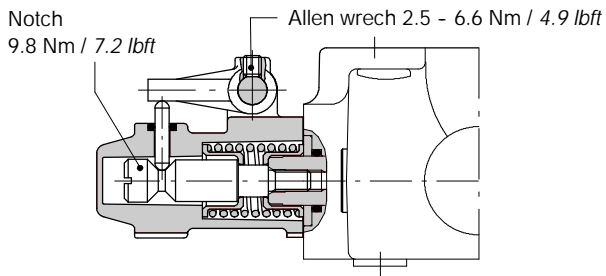
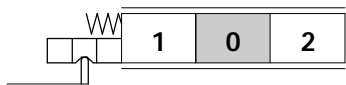

Other configurations

8MS1 kit
microswitch operation in position 1

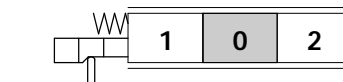

8MS2 kit
microswitch operation in position 2

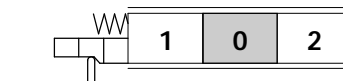

Microswitches for 8MS kits

Complete with rubber cover and mounting screws

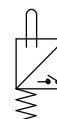

M51 code: 5MIC100

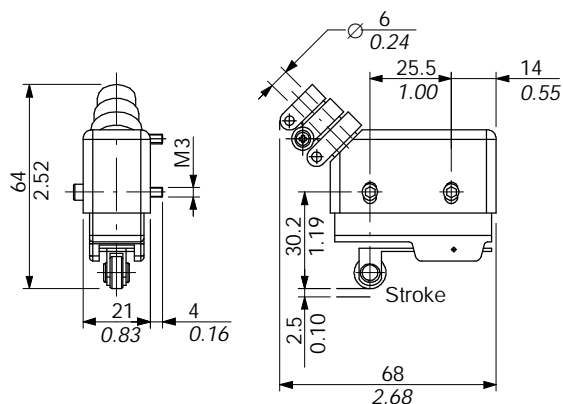

Operating features

Current / voltage max. : 15 A / 480 VAC
 : 0,25 A / 250 VDC
 Weather protection : IP51

M67 code: 5MIC200

Dedicated bracket is needed for the assembly
 code: 3FLA225052

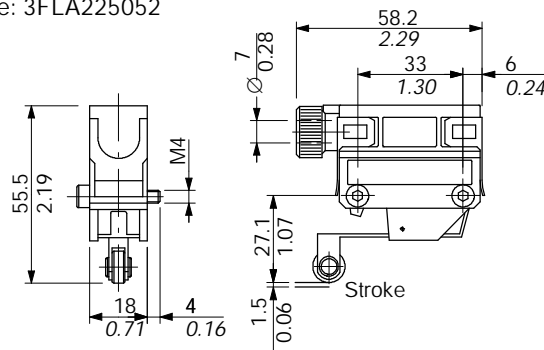

Operating features

Current / voltage max. : 5 A / 250 VAC
 : 0,25 A / 230VDC
 Weather protection : IP67

SDM080

"B" side options

Lever box L

Reinforced nylon with protection boot lever pivot box; it can be rotated 180° (L180 configuration).

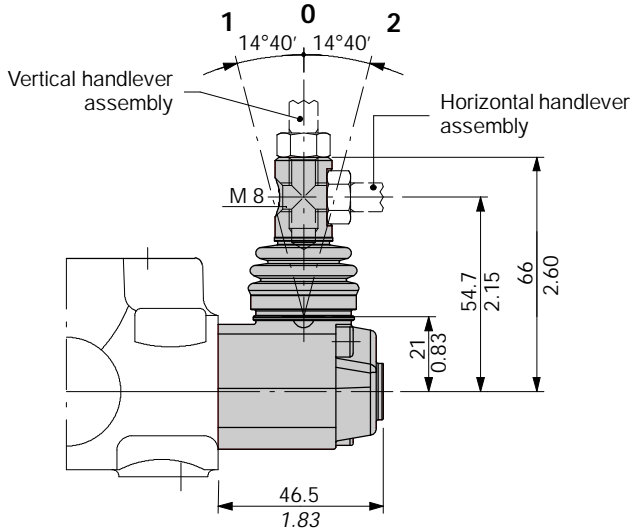
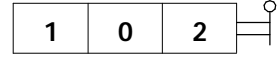

L180 configuration

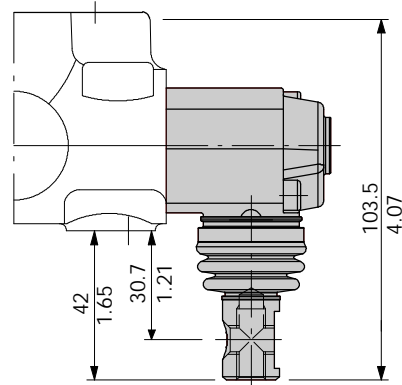

NOTE - The handle lever must be ordered separately (see page 9).

Dust proof plate SLP

Mechanical control with dust proof plate

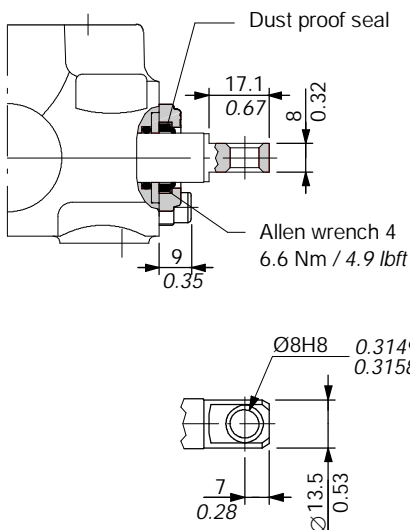
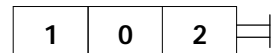

TQ cable connection

Waterproof cap for remote control with flexible cable.

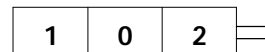
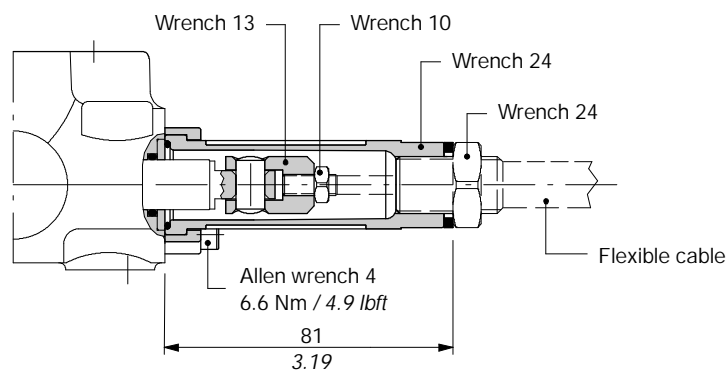

Example of cable control

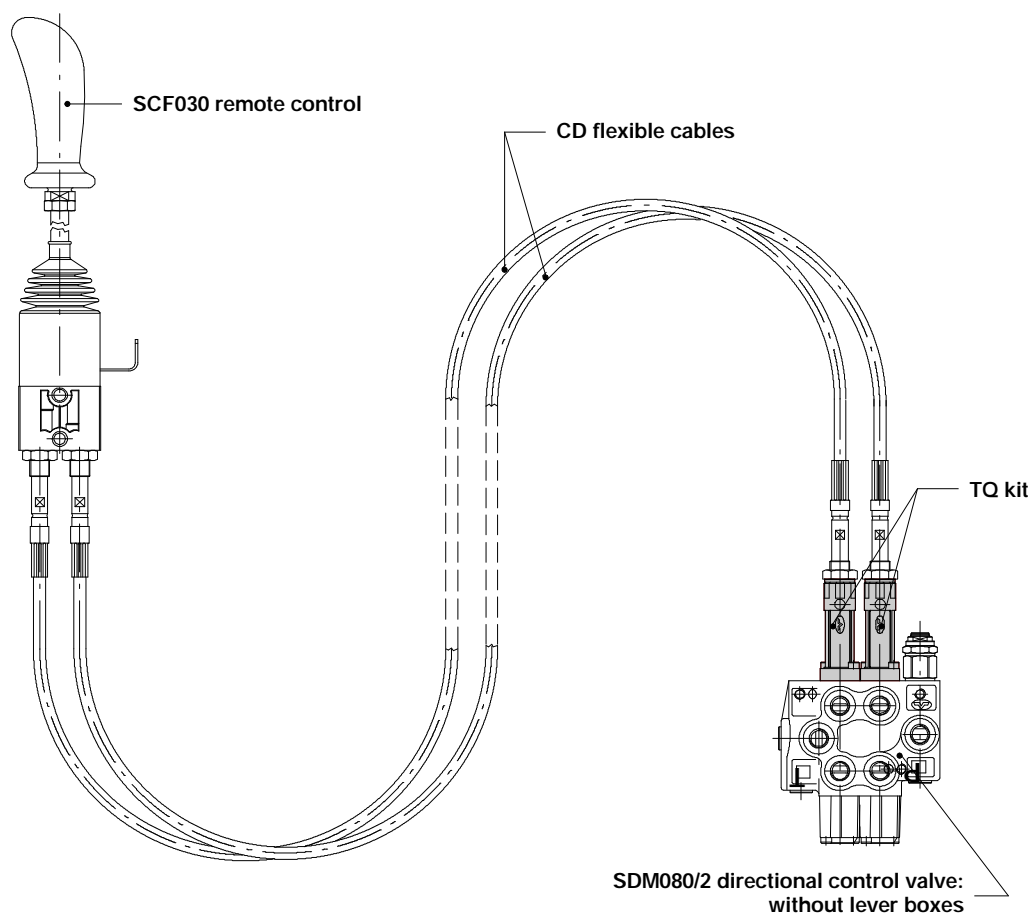

NOTE - For more information concerning remote cable control require appropriate documentation.

Mechanical joystick LCB

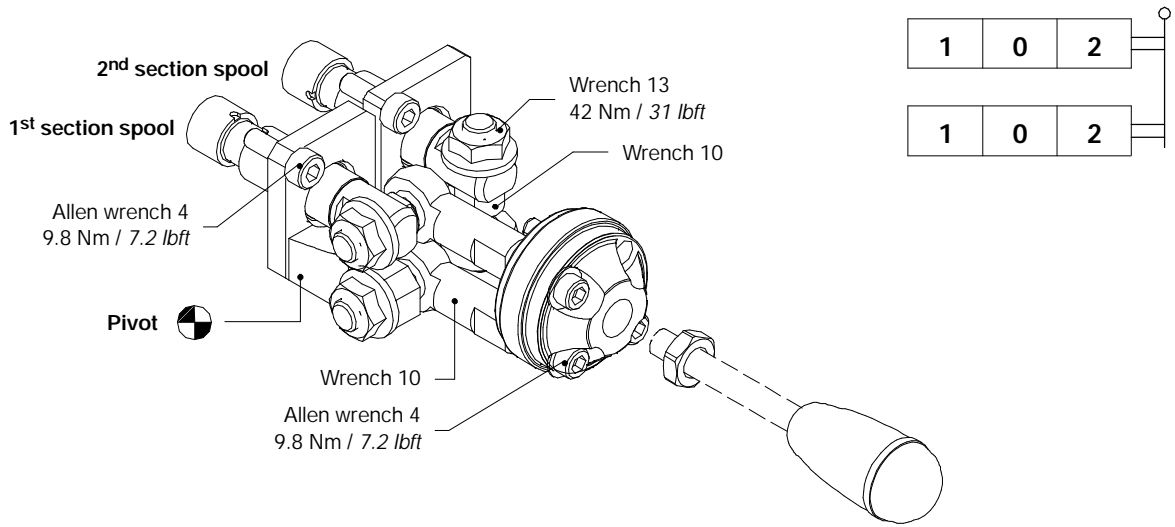

NOTE - The handlever must be ordered separately (see page 9).

Dimensions and movement scheme

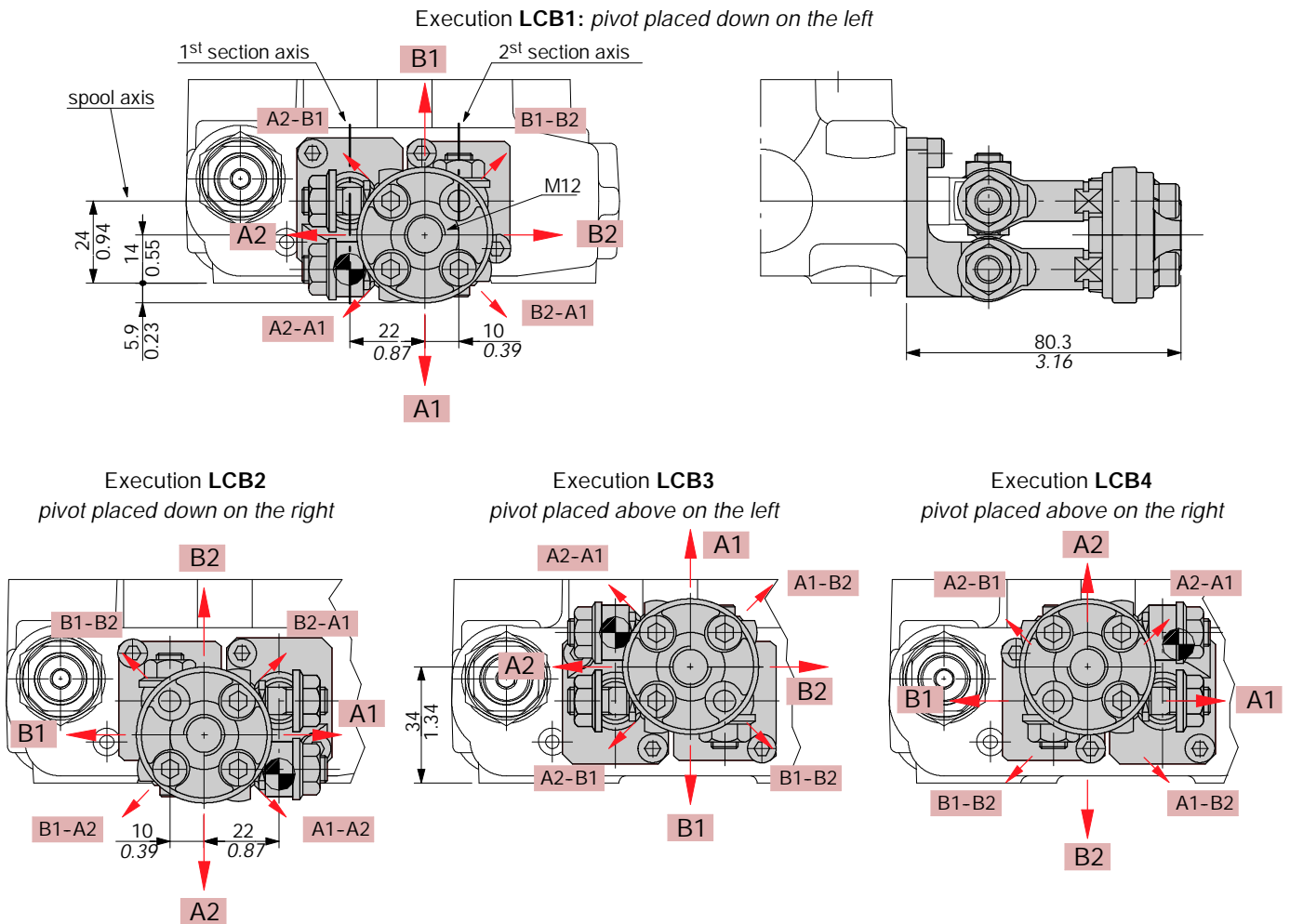

PSA: upper (standard)

See page 6

PSC: "A" control side

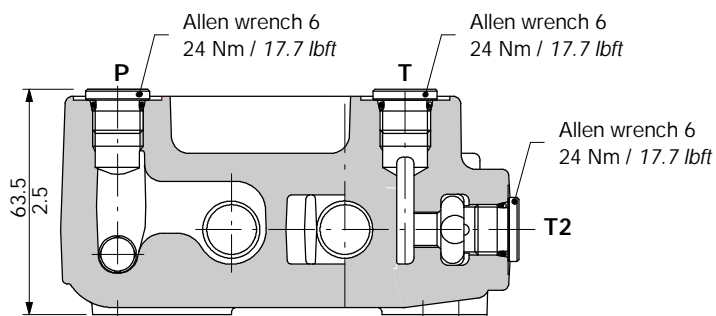

Ex.: SDM080/2-P(TG3-175)/18L/18L/PSC

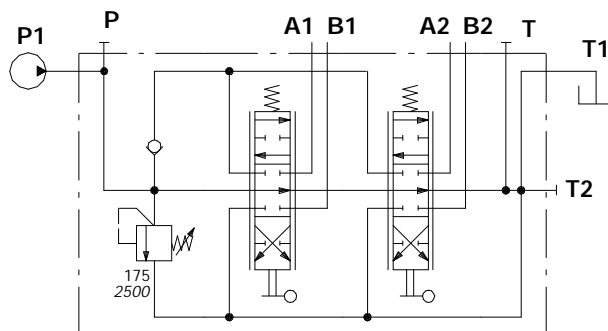

AE: with power beyond

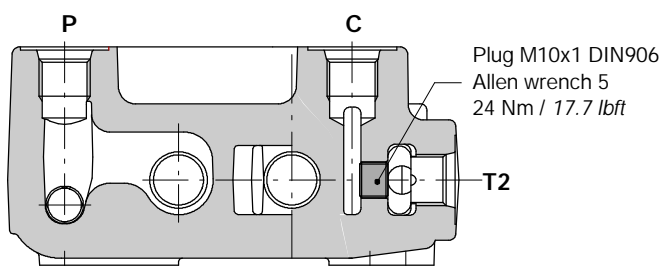

Ex.: SDM080/2-P(TG3-175)/18L/18L/AE

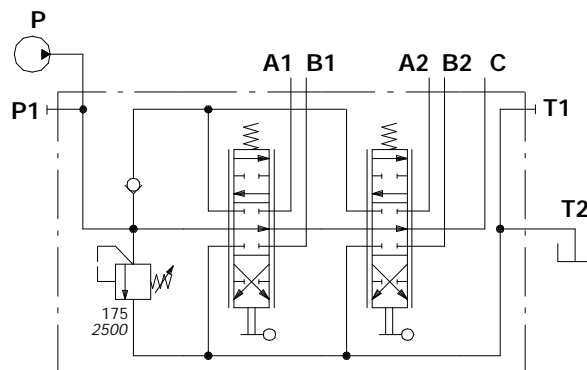

AEK: closed center

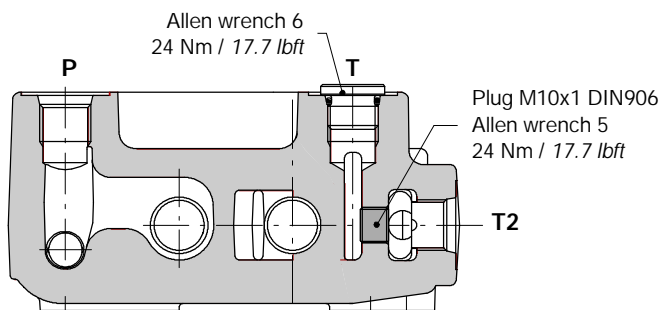

Ex.: SDM080/2-P(TG3-175)/18L/18L/AEK

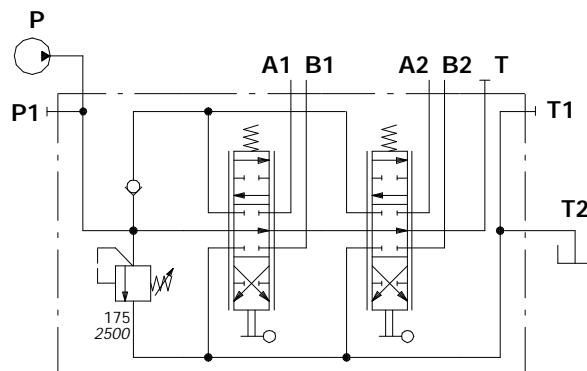

Installation and maintenance

The SDM080 valve is assembled and tested as per the technical specification of this catalog.

Before the final installation on your equipment, follow the below recommendations:

- the valve can be assembled in any position, in order to prevent body deformation and spool sticking mount the product on a flat surface;
- in order to prevent the possibility of water entering the lever box and spool control kit, do not use high pressure wash down directly on the valve;
- prior to painting, ensure plastic port plugs are tightly in place.

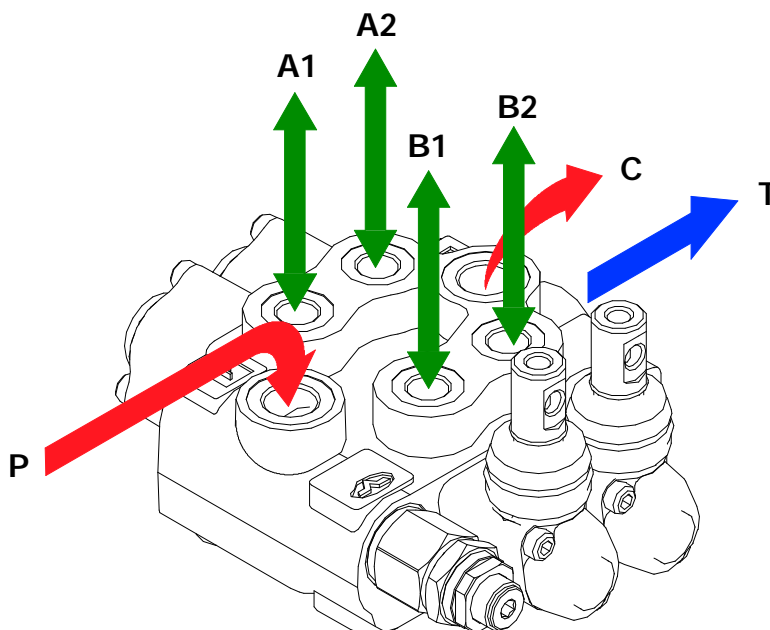

Power beyond configuration

Fitting tightening torque - Nm / lbft

THREADS TYPE	P and C ports	A and B ports	T port
BSP (ISO 228/1)	G 3/8	G 1/4	G 3/8
With O-Ring seal	35 / 25.8	25 / 18.4	35 / 25.8
With copper washer	40 / 29.5	30 / 22.1	40 / 29.5
With steel and rubber washer	30 / 22.1	16 / 11.8	30 / 22.1
UN-UNF (ISO 11926-1)	9/16-18 UNF-2B (SAE 6)	9/16-18 UNF-2B (SAE 6)	9/16-18 UNF-2B (SAE 6)
With O-Ring seal	30 / 22.1	30 / 22.1	30 / 22.1
METRIC (ISO 6149-3)	M18x1.5	M14x1.5	M18x1.5
With O-Ring seal	45 / 33.2	35 / 25.8	45 / 33.2

NOTE - These torque are recommended. Assembly tightening torque depends on many factors, including lubrication, coating and surface finish. The manufacturer shall be consulted.

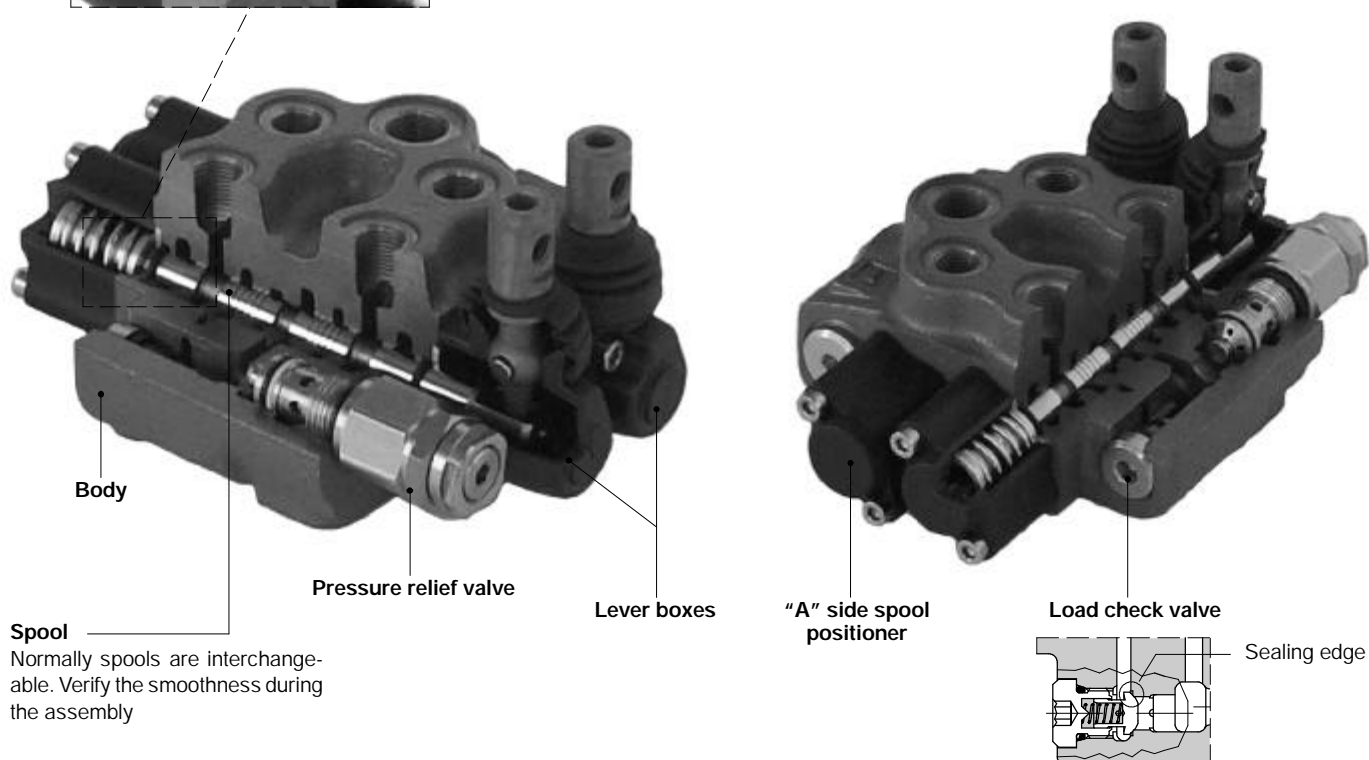
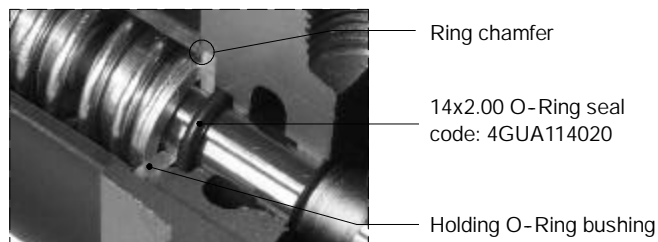

NOTE - All articulated parts inside cap, lever box and mechanical joystick are lubricated with synthetic base grease grade NLGI2

Malfunction	Cause	Remedy
External leakage pivot box lever or control kit side.	Worn spool seal due to mechanical actuation or high back pressure.	Locate the leakage and replace the seal. Check back pressure level.
Excessive internal leakage on A and B ports.	Increase clearance between spools and body due to high wear	Replace the directional control valve and check the oil contamination level.
Dropping load during transition while raising	High leakage on the load check valve.	Remove the load check valve and clean the seat.
Inability to build pressure on A and B ports.	Pressure relief valve blocked open. Low pump pressure and flow.	Remove and clean or replace the valve. Check the pump and circuit.

Notes

The SDM080 valve can be supplied with one coat of opaque black paint (**CVN** configuration).

Example of specification: SDM080/2-P(TG3-175)/18L/18L/PSA-<**CVN**>

NOTE - *For different color consult Customer Service.*



WALVOIL S.P.A.

42100 REGGIO EMILIA • ITALY • VIA ADIGE, 13/D
TEL. +39.0522.932411 • FAX +39.0522.300984
E-MAIL: INFO@WALVOIL.COM • HTTP: //WWW.WALVOIL.COM

SALES DEPARTMENT

TEL. +39.0522.932555 • FAX +39.0522.932455

DAT001A