



DFE140

Solenoid control sectional diverter valves

- 6 - 8 - 10 ways configuration
- Galvanized body
- Antishock valve block stackable with the diverter valve

This catalogue shows technical specifications and diagrams measured with mineral oil of 46 mm²/s (46 cSt) viscosity at 40°C - (104°F) temperature.

WORKING CONDITIONS		
N. of available ways		6 - 8 - 10
Max. flow rating		80 l/min (21.1 US gpm)
Max. pressure	without drain	200 bar (2900 psi)
	with drain	315 bar (4600 psi)
Available supply voltage	VDC	see reference page 148
Nominal power		60 W
Internal leakage A(B)⇒T	Δp = 100 bar (1450 psi)	10 cm ³ /min (0.61 in ³ /min)
Fluid		Mineral based oil
Tie rod tightening		25 Nm (18.4 lbft)
Fluid temperature	with NBR (BUNA-N) seals	from -20°C to 80°C (from -4°F to 176°F)
	with FPM (VITON) seals	from -20°C to 100°C (from -4°F to 212°F)
	operating range	from 15 to 75 mm ² /s (from 15 to 75 cSt)
Viscosity	min.	12 mm ² /s (12 cSt)
	max.	400 mm ² /s (400 cSt)
Max. level of contamination		20/18/15 - ISO 4406 - NAS 1638 - class 9
Ambient temperature for working conditions		from -20°C to 50°C (from -4°F to 122°F)

NOTE - For different working conditions please contact Sales Dept.

Available threads

PORTS THREAD		
ALL PORTS	BSP	UN-UNF
DFE140	G 1/2	7/8-14 (SAE 10)
PILOT PORTS		
L	G 1/4	9/16-18 (SAE 6)

Dimensional data - hydraulic circuit - performance data

6 ways

The drawing below show diverter valve in 6-way configuration with anti-shock valves block

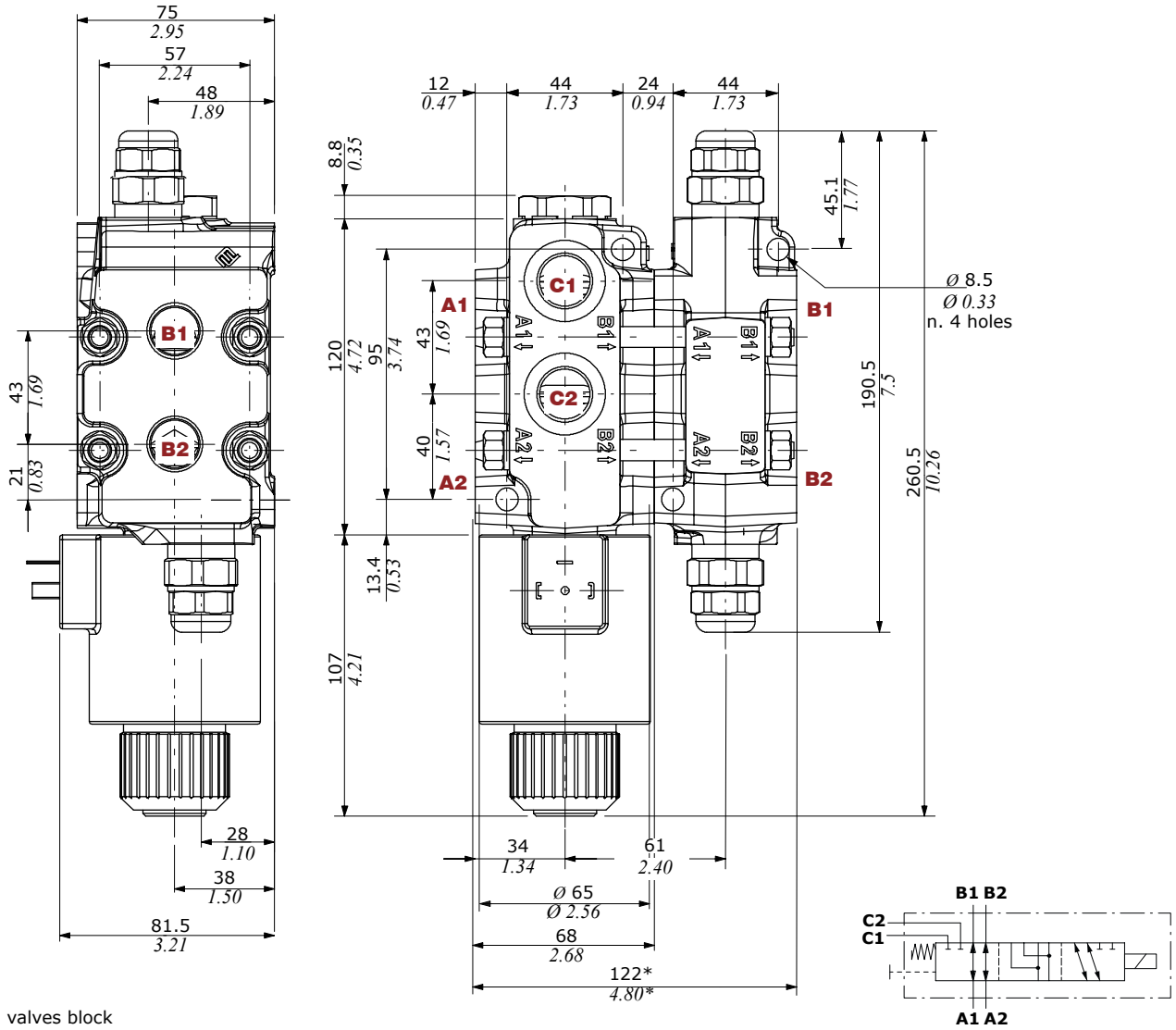

(*) - with P3 valves block

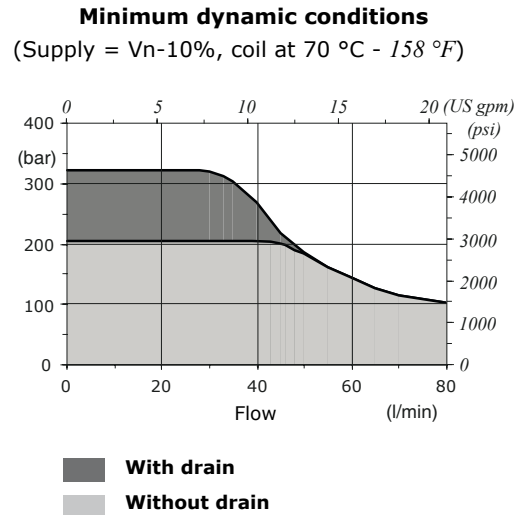
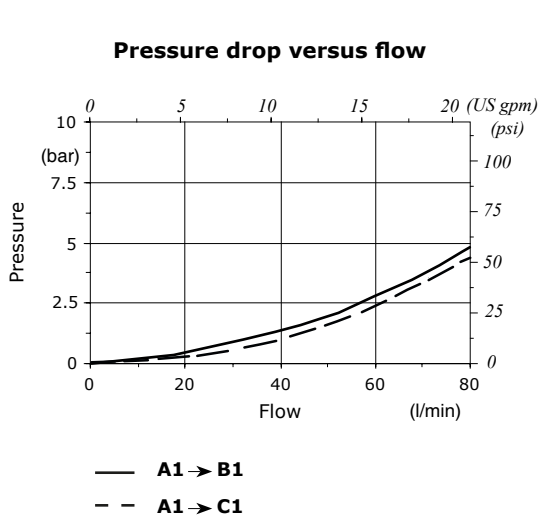

Dimensional data - hydraulic circuit - performance data

8 ways

The drawing below show diverter valve in 8-way configuration with anti-shock valves block

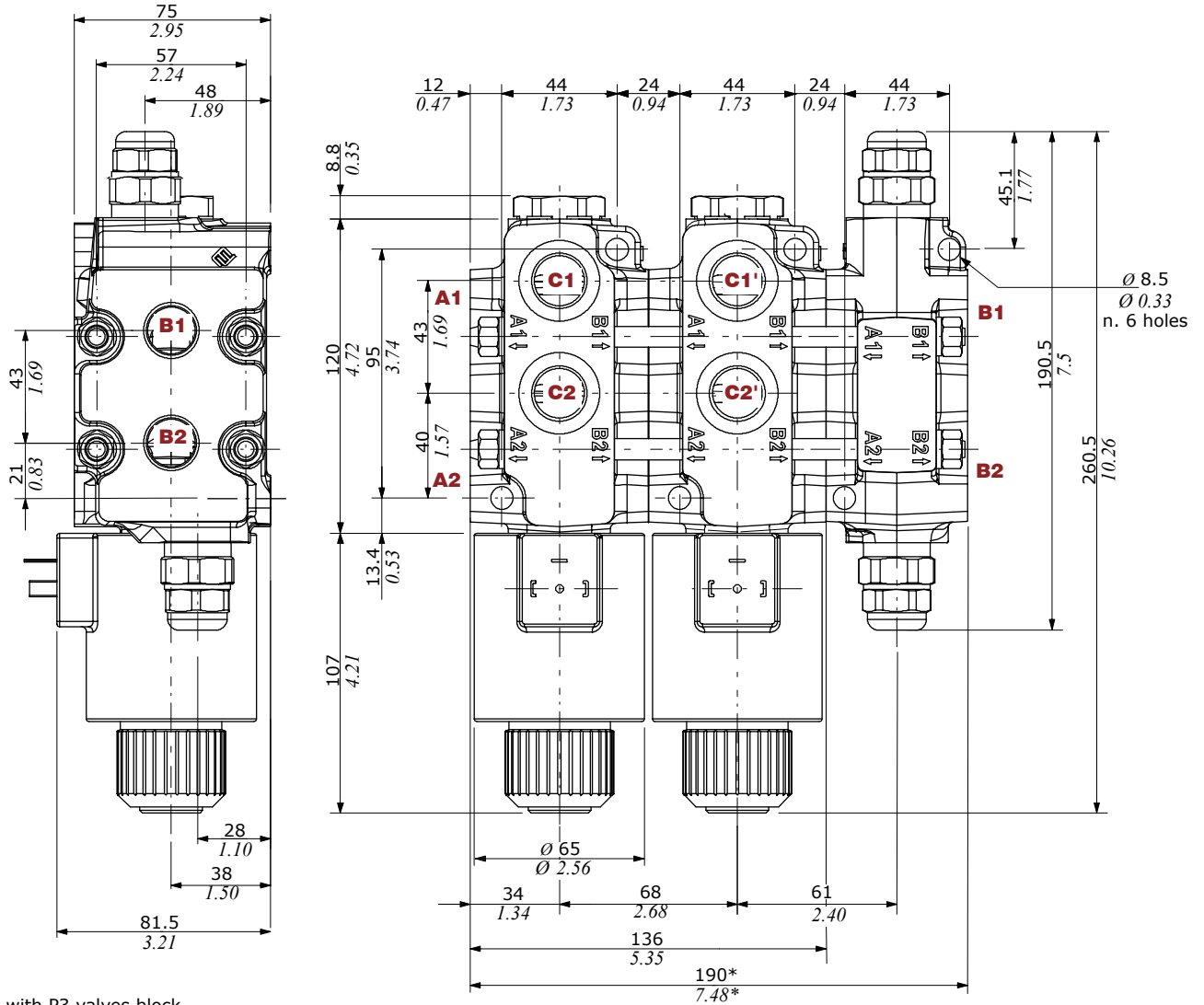

(*) - with P3 valves block

Pressure drop versus flow

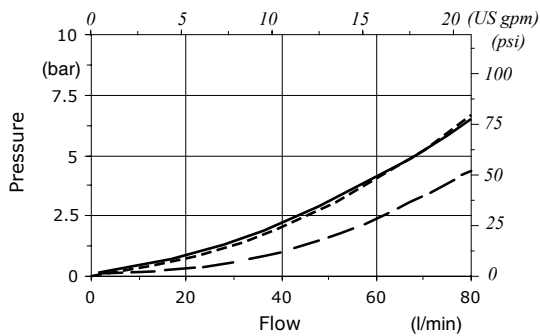

— A1 → B1 A1 → C1'
 - - A1 → C1

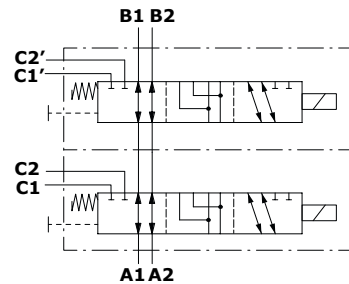

Dimensional data - hydraulic circuit - performance data

10 ways

The drawing below show diverter valve in 10-way configuration with anti-shock valves block

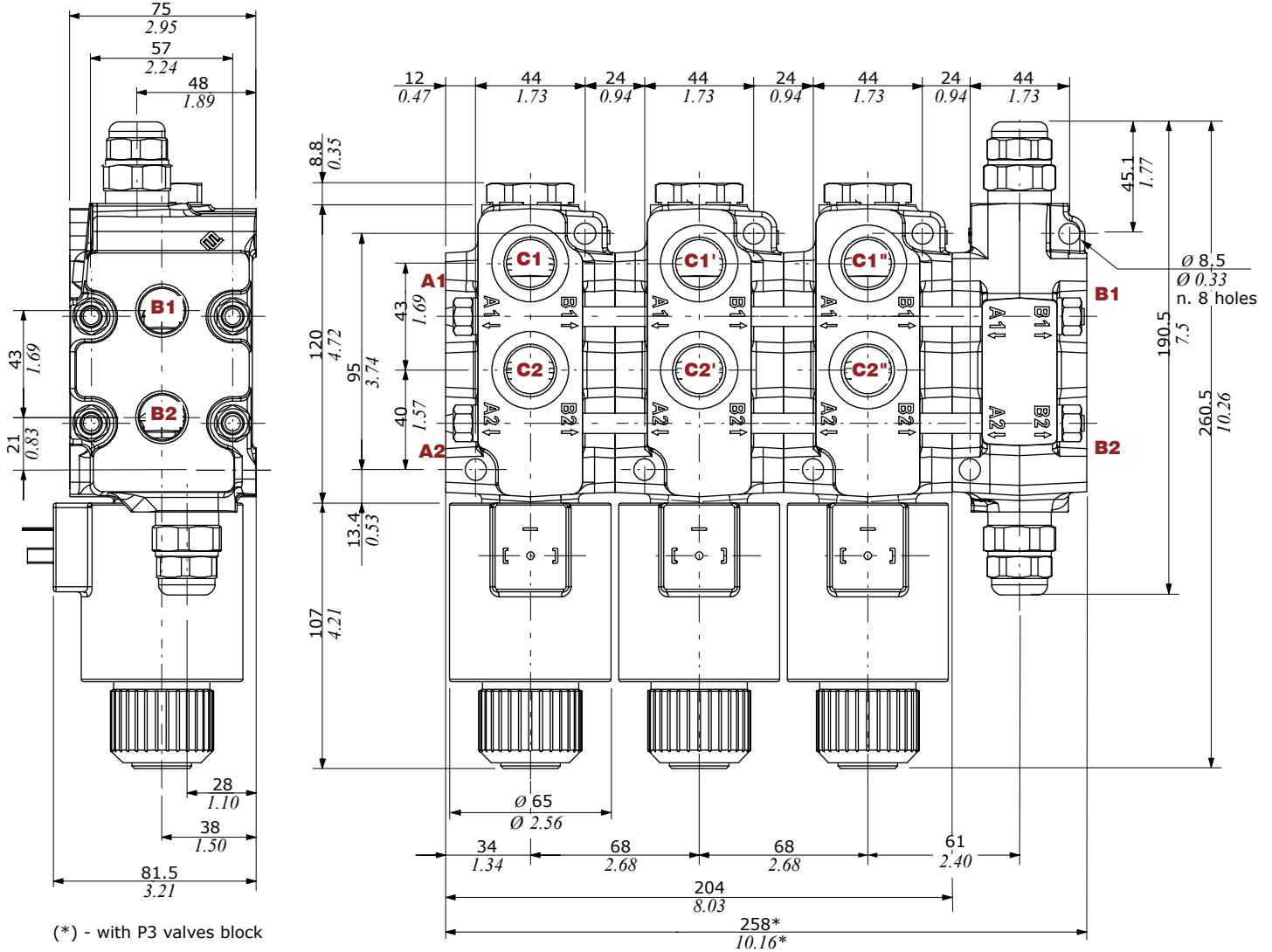

Pressure drop versus flow

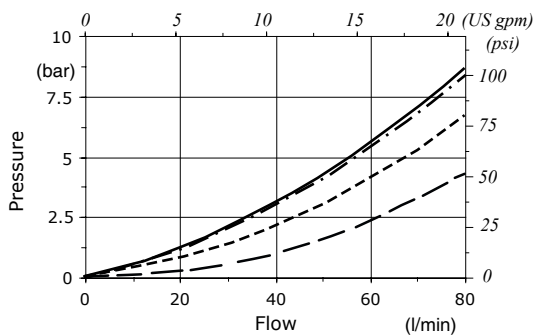

— A1 → B1 A1 → C1'
 - - A1 → C1 - · - · A1 → C1''

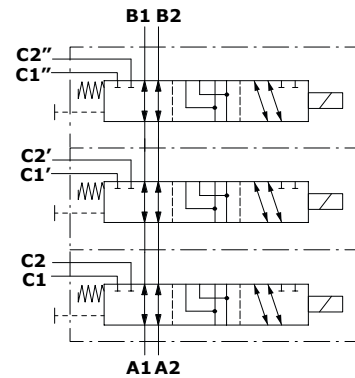

Part ordering codes

Example:

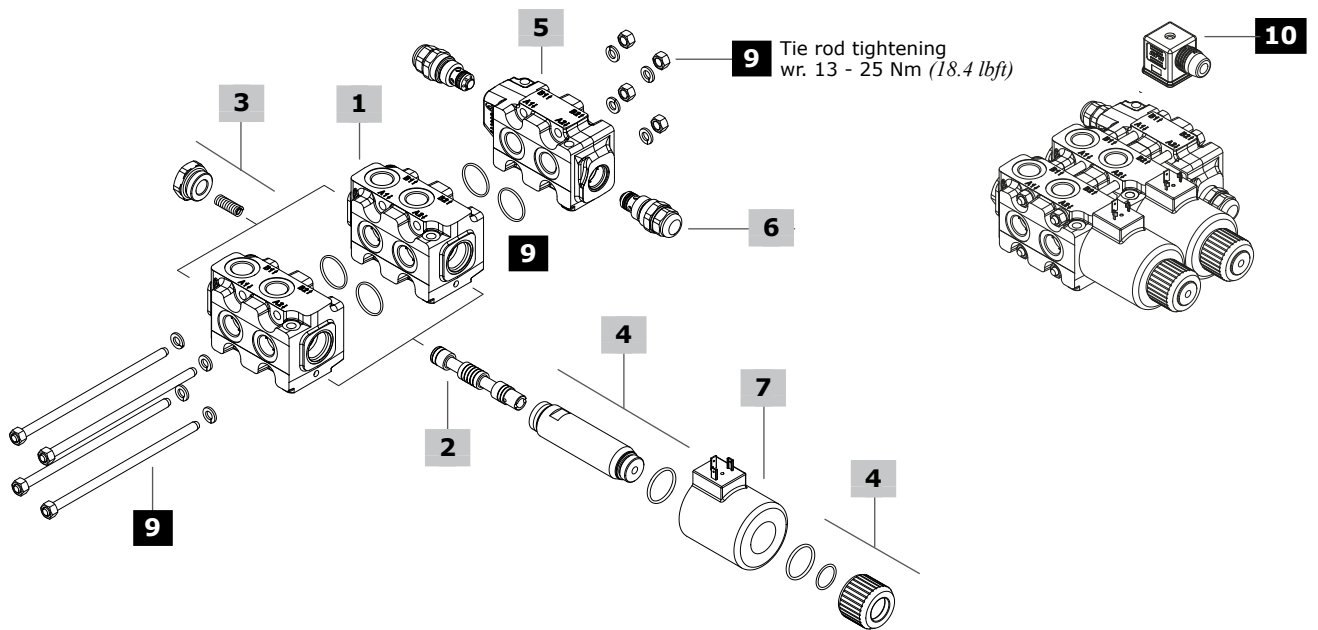
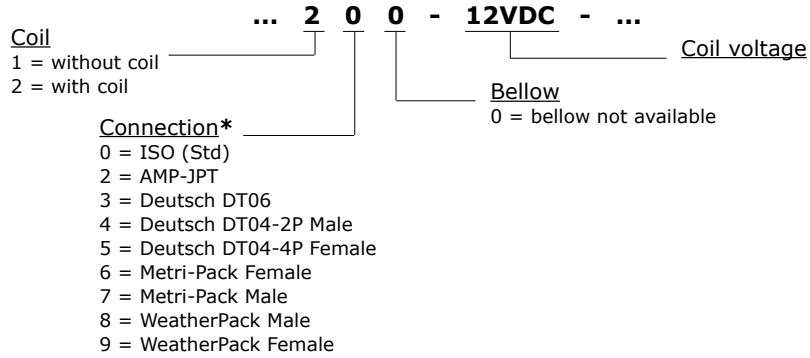
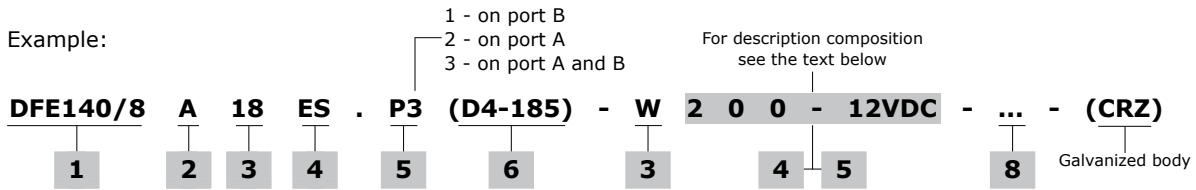

Part ordering codes

1 Body kit* page 145

TYPE	CODE	DESCRIPTION
DFE140/6-8-10	3C02280302	6 ways body kit

2 Spools page 145

TYPE	CODE	DESCRIPTION
A	3CAS110640	A1/A2 in B1/B2 in pos. 1. A1/A2 in C1/C2 in pos. 2. Ports connected in transit position
B	3CAS110740	A1/A2 in B1/B2 in pos. 1. A1/A2 in C1/C2 in pos. 2. Ports closed in transit position
H	3CAS110845	A1/A2 in B1/B2 in pos. 1. A1/A2 in C1/C2 in pos. 2. Port connected to drain in transit position
N	3CAS110941	As type B, for right inlet

3 Positioner kit page 146

TYPE	CODE	DESCRIPTION
18...W	5TAP005	Spring return in pos. 1
18...Y	5GIU010*	Spring return in pos. 1, with G1/4 drain port

4 Solenoid kit page 146

TYPE	CODE	DESCRIPTION
ES	5SOL519003	Tube assembly without protective bellow

5 Valves block* page 147

TYPE	CODE	DESCRIPTION
P3	3C02780301	Cross-over antishock valve body

6 Antishock valves page 147

With fixed setting: setting is referred to valve opening

TYPE	CODE	DESCRIPTION
P(D2-80)	X005125095	Setting 80 bar (1150 psi)
P(D2-110)	X005125110	Setting 110 bar (1590 psi)
P(D3-125)	X005125145	Setting 125 bar (1800 psi)
P(D3-140)	X005125155	Setting 140 bar (2050 psi)
P(D3-170)	X005125190	Setting 170 bar (2450 psi)
P(D4-185)	X005125216	Setting 185 bar (2700 psi)
P(D4-210)	X005125245	Setting 210 bar (3050 psi)
P(D4-240)	X005125270	Setting 240 bar (3500 psi)
P1T - P2T	3XTAP524290	Blanking plug P1-P2

7 Coil

For list of available coils see pages 148

8 Body threading

Specify threading always when it is different from **BSP** standard

9 Tie rods kit and O-ring seals

CODE	DESCRIPTION
5TIR108134	For DFE140/8 diverter valves
5TIR108202	For DFE140/10 diverter valves
with valves block:	
5TIR108121	For DFE140/6.P3 diverter valves
5TIR108189	For DFE140/8.P3 diverter valves

10 Accessories

For list of available connectors see pages 148

(*) - Codes are referred to **BSP** thread

Type A

A1/A2 in B1/B2 in pos. 1.
Ports connected in transit position

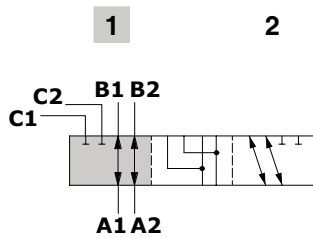

Spool stroke

Position 2: + 5.8 mm (0.22 in)

Type B

A1/A2 in B1/B2 in pos. 1.
Ports closed in transit position

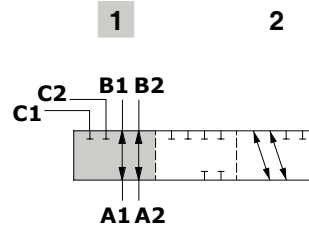

Spool stroke

Position 2: + 5.8 mm (0.22 in)

Type H

A1/A2 in B1/B2 in pos. 1.
Port connected to drain in transit position

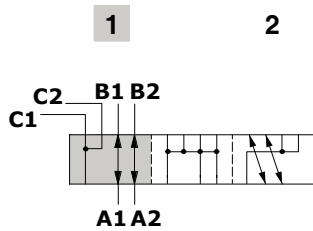

Spool stroke

Position 2: + 5.8 mm (0.22 in)

Type N

As type B, for right inlet

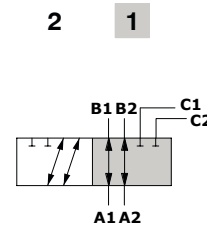

Spool stroke

Position 2: + 5.8 mm (0.22 in)

Positioner kit

With spring return in position 1

Type 18W
With plug

Type 18Y
With G1/4 drain port

Wrenches and tightening torque
Z = wrench 32 - 42 Nm (31 lbft)

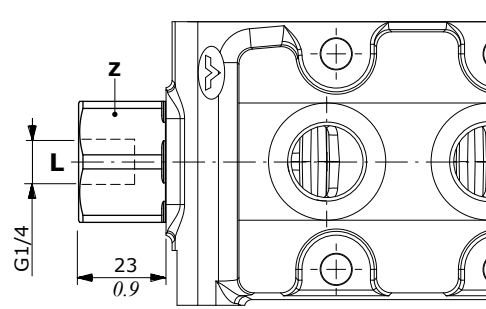
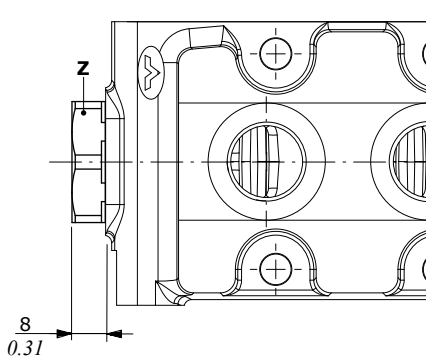

Solenoid kit

ES tube assembly kit

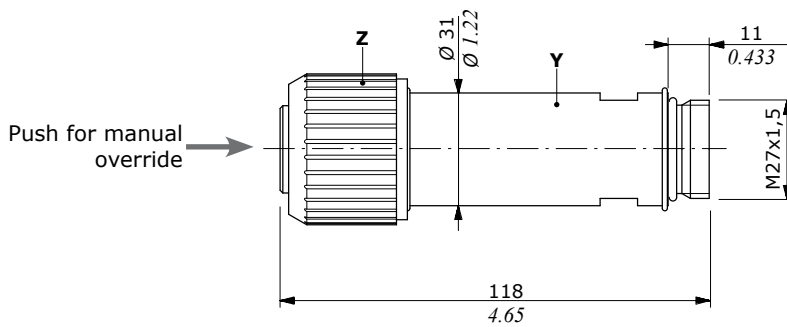

Wrenches and tightening torque
Y = wrench 27 - 24 Nm (17.7 lbft)
Z = 24 Nm (17.7 lbft)

P3 block complete with antishock valves

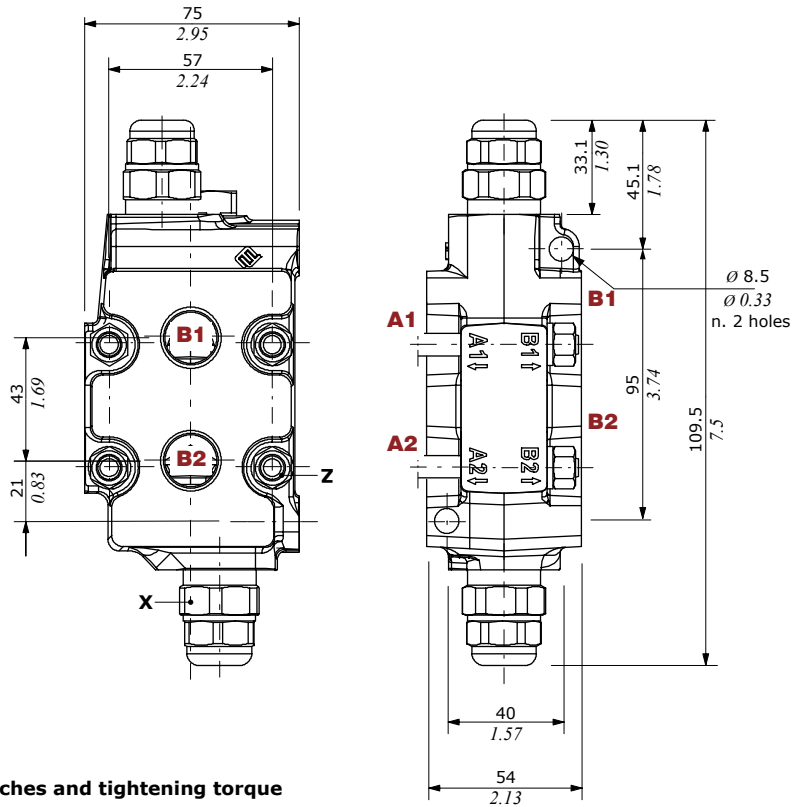

Wrenches and tightening torque

X = wrench 27 - 42 Nm (31 lbft)
 Z = wrench 13 - 24 Nm (17.7 lbft)

Configuration with valve on each workport (P3)

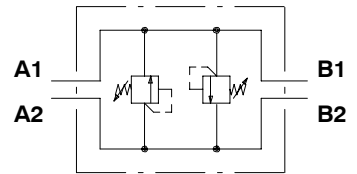

Configuration with valve on workport A (P2)

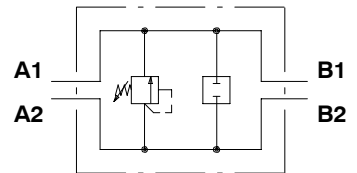

Configuration with valve on workport B (P1)

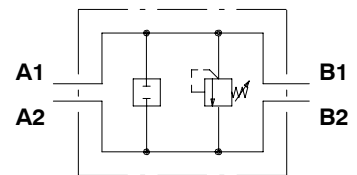

Antishock valves performance data

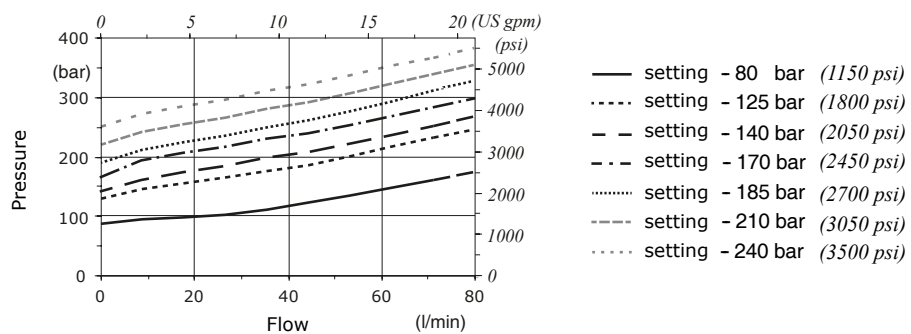

Coils and accessories

Type	Voltage	Ordering codes					Flying leads without connector
		ISO4400	Deutsch DT	AMP JPT	Packard Weatherpack	Packard Metri-pack	
D19	12 VDC	4SOL519112	4SOL519402 ⁽⁶⁾	-	-	-	-
	20 VDC	4SOL519120	-	-	-	-	-
	24 VDC	4SOL519124	4SOL519404 ⁽⁶⁾	-	-	-	-
	94 VDC	4SOL519194	-	-	-	-	-
	192 VDC	4SOL519292	-	-	-	-	-
Mating connectors		4CN1009995	5CON140031	-	-	-	-

Notes: ⁽¹⁾ supply with AC and use only with rectifier connector - ⁽²⁾ with flying leads - ⁽³⁾ with bidirectional diode - ⁽⁴⁾ with unidirectional diode ⁽⁵⁾ integrated perpendicular type - ⁽⁶⁾ integrated parallel type

Features

Nominal voltage tolerance: $\pm 10\%$
 Nominal power.....: 60 W
 12/20/24/94/192 VDC
 Nominal current.....: 5 A @ 12 VDC
 : 3 A @ 20 VDC
 : 2.5 A @ 24 VDC
 : 2.5 A @ 94 VDC
 : 0.31 A @ 192 VDC
 Insulation.....: Class H (180°C - 356 °F)
 Weather protection..... : IP65 - ISO4400
 : IP69K - Deutsch DT
 Insertion.....: 100%

ISO4400 connector

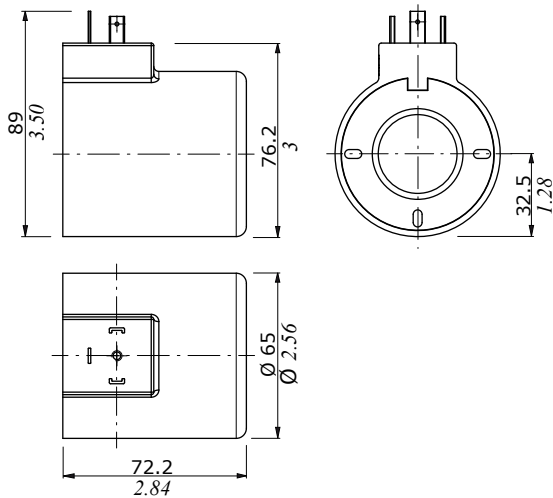

DEUTSCH DT04 connector (Parallel type)

