



EC..T type flow restrictor - 2 way

- Solenoid proportional type
- To be combined with an external compensator
- From SAE08 to SAE16 cavities

Technical specifications and diagrams are measured with mineral oil of 46 cSt viscosity at 40°C (104°F) temperature.

		EC08T	EC10T	EC12T	EC16T
Nominal flow ⁽¹⁾	with 5 bar (72.5 psi) stand-by	35 l/min (9.2 US gpm)	44 l/min (11.6 US gpm)	55 l/min (15.5 US gpm)	70 l/min (18.5 US gpm)
	with 10 bar (145 psi) stand-by	44 l/min (11.6 US gpm)	58 l/min (15.3 US gpm)	70 l/min (18.5 US gpm)	97 l/min (25.6 US gpm)
Max. pressure		350 bar (5100 psi)			
Oil leakage	at 350 bar (5100 psi)	0.25 cm ³ /min (0.015 in ³ /min)	0.25 cm ³ /min (0.015 in ³ /min)	0.25 cm ³ /min (0.015 in ³ /min)	0.35 cm ³ /min (0.021 in ³ /min)
Fluid		mineral based oil			
Viscosity		12-200 cSt			
Max level of contamination		18/16/13 ISO4406			
Fluid temperature	with NBR seals with FPM seals	from -20°C (-4°F) to 80°C (176°F) from -20°C (-4°F) to 100°C (212°F)			
Environmental temp. for working conditions		from -20°C (-4°F) to 50°C (122°F)			
Cavity		SAE 08/2	SAE 10/2	SAE 12/2	SAE 16/2
Coil type ⁽²⁾		BH			
Nominal voltages		12 VDC - 24 VDC ± 10%			
Power rating		22.8 W (12 VDC) 22.5 W (24 VDC)			
Max control current		12 V -> 1.70 A - 24 V -> 0.85 A (BH)			
Dither frequency		from 100 Hz to 120 Hz			
Weight		0.275 kg (0.61 lb)	0.310 kg (0.68 lb)	0.390 kg (0.86 lb)	0.490 kg (1.08 lb)

NOTE - For different conditions, please contact Walvoil Sales Dpt. - ⁽¹⁾ Values are checked with cartridge in parallel with compensator
⁽²⁾ For coils further features see from page 206.

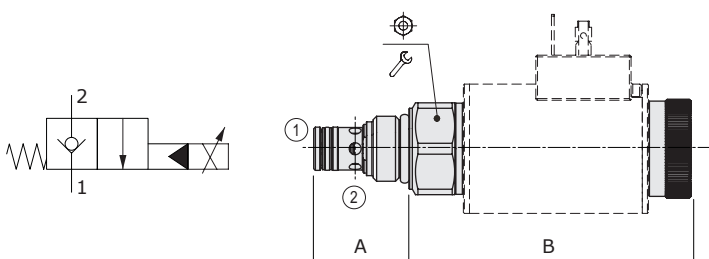

Valve type	A		B		⌀	Nm	lbf ^{ft}
	mm	in	mm	in			
EC08T	28.1	1.11	83	3.27	27	50	37
EC10T	32.5	1.28	83	3.27	27	50	37
EC12T	45	1.77	82.5	3.25	32	85	63
EC16T	45.6	1.80	81	3.19	32	85	63

For dimensions with different type of emergency see page 213

Ordering codes and description composition

EC10T/A0NB

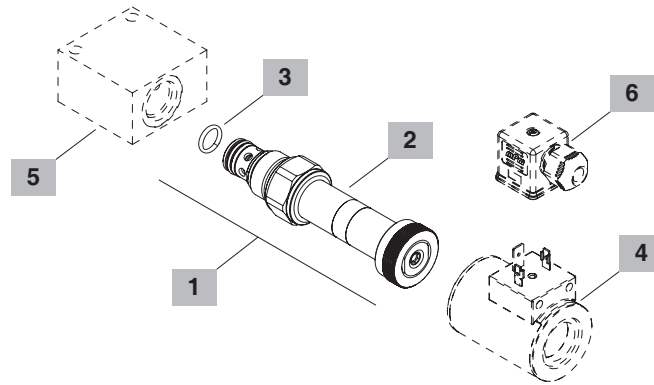
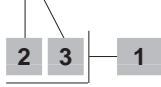

1 Cartucce

TYPE	CODE	DESCRIPTION
SAE cavity 08/2		
EC08T/A0NB	0EC08002056	Without emergency
EC08T/A0TB	0EC08002058	Screw type emergency
EC08T/A0QB	0EC08002073	"Push&twist" emergency
SAE cavity 10/2		
EC10T/A0NB	0EC10002025	Without emergency
EC10T/A0TB	0EC10002027	Screw type emergency
EC10T/A0QB	0EC10002029	"Push&twist" emergency
SAE cavity 12/2		
EC12T/A0NB	0EC12002018	Without emergency
EC12T/A0TB	0EC12002019	Screw type emergency
EC12T/A0QB	0EC12002020	"Push&twist" emergency
SAE cavity 16/2		
EC16T/A0NB	0EC16002033	Without emergency
EC16T/A0TB	0EC16002035	Screw type emergency
EC16T/A0QB	0EC16002038	"Push&twist" emergency

2 Emergenze

TYPE	DESCRIPTION
N	Without emergency
T	Screw type emergency
Q	"Push&twist" emergency

3 Seals

TYPE	DESCRIPTION
B	NBR (Buna) Std configuration without addition
V	For valve with FPM (Viton) o-ring seals, contact Sales Dept.

4 Bobine

TYPE	CODE	DESCRIPTION
BH 12VDC	4SLD001200	Coil 12VDC-ISO4400

For complete coils list see from page 206
It is possible also combine coils BQP19

5 Valve body

TYPE	CODE	DESCRIPTION
SAE 08/2-G 3/8	3CC0820C11	Aluminium body for cavity 08 valve, G3/8 std thread
SAE 10/2-G 3/8	3CC1020C11	Aluminium body for cavity 10 valve, G3/8 std thread
SAE 12/2-G 1/2	3CC1220D11	Aluminium body for cavity 12 valve, G1/2 std thread
SAE 16/2-G 3/4	3CC1620E11	Aluminium body for cavity 16 valve, G3/4 std thread

Note: aluminium body can stand up to 210 bar (3050 psi)
For steel bodies or different threading see from page 215

6 Connector

TYPE	CODE	DESCRIPTION
ISO4400	4CN1009995	Connector

For complete connectors list see from page 206

**EC08T
pressure drop**

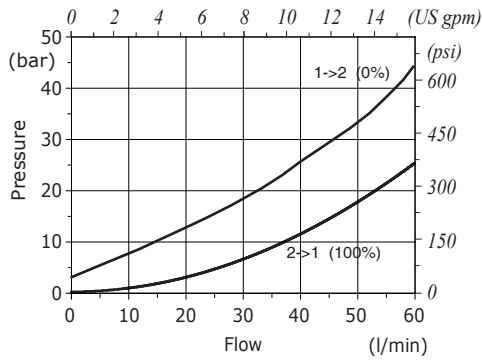

**EC08T
pressure drop**

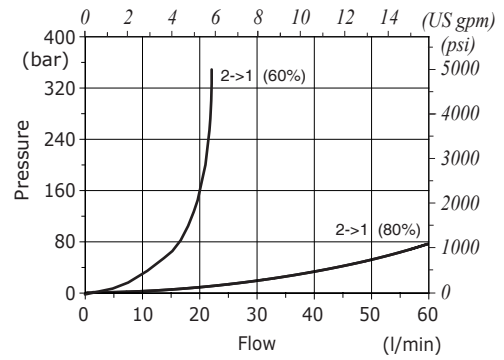

**EC08T
flow regulating vs. % max. control current**

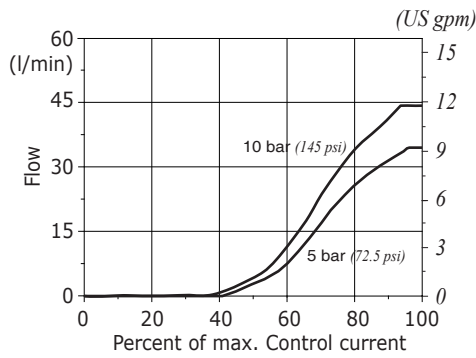

**EC10T
pressure drop**

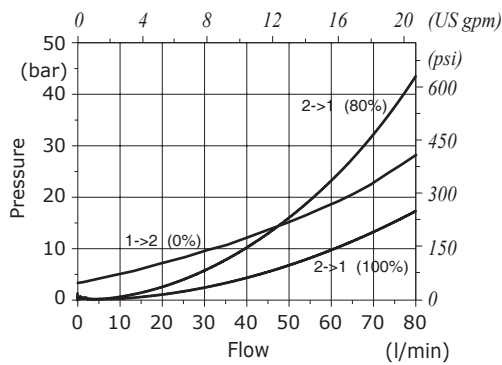

**EC10T
pressure drop**

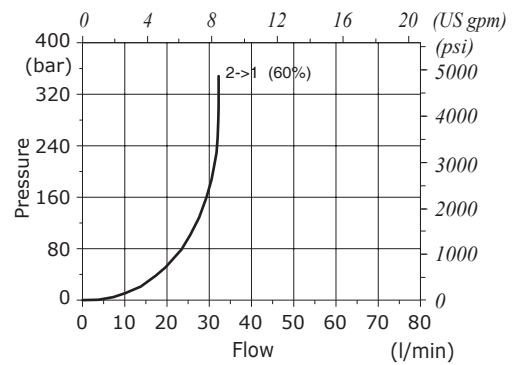

**EC10T
flow regulating vs. % max. control current**

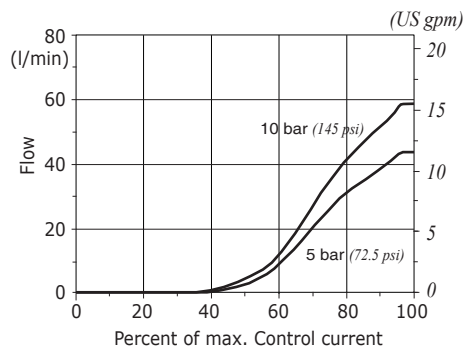

Rating diagrams

**EC12T
pressure drop**

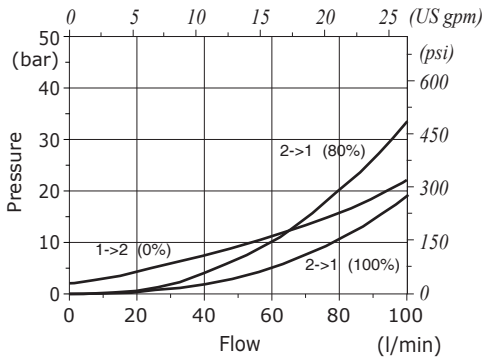

**EC12T
pressure drop**

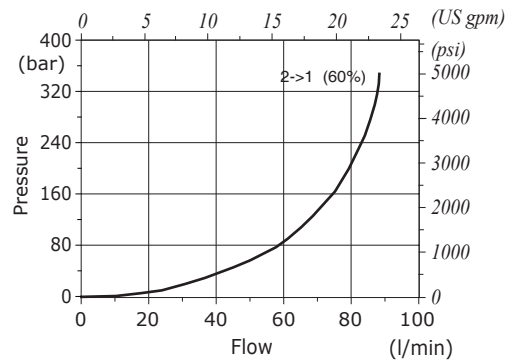

**EC12T
flow regulating vs. % max. control current**

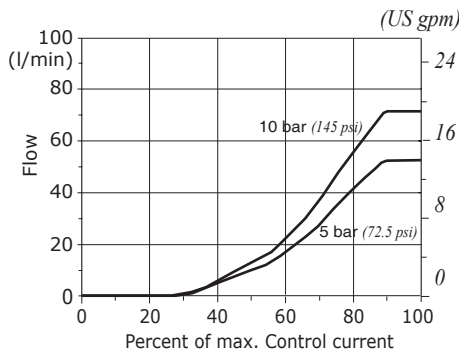

**EC16T
pressure drop**

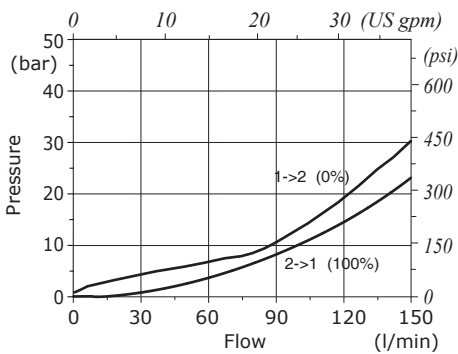

**EC6T
pressure drop**

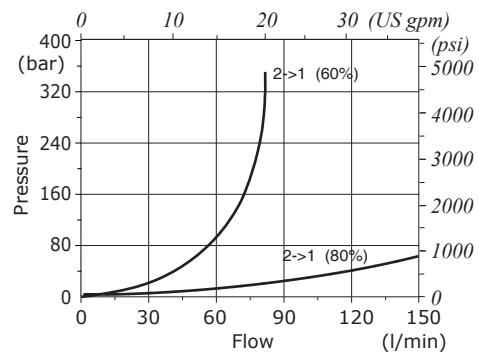

**EC16T
flow regulating vs. % max. control current**

