

NEW

MD10M

Shockless pressure relief
valve cartridges

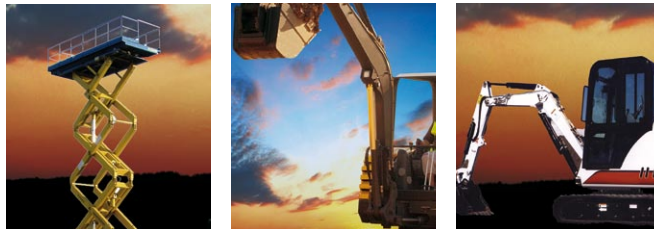

**A simple and flexible solution for
dampening pressure peaks in
hydraulic systems**



MD10M

Shockless pressure relief valve cartridge

PATENT PENDING



- Cushioned relief valve for dampening pressure peaks in low leakage hydraulic systems
- Improved performances
- Reduced dimensions
- Several adjustable settings available
- Various reaction times
- Extremely reduced leakage
- SAE10 cavity

Walvoil is pleased to present the new shock-less pressure relief valve cartridge **MD10M** for the control of pressure peaks in hydraulic systems. The new **MD10M** can be used in many applications: earth moving machines and industrial vehicles.

Working conditions

This catalogue shows technical specifications and diagrams measured with mineral oil of 46 cSt viscosity at 40° (104°F) temperature.

Nominal flow rating	up to 60 l/min (15.8 US gpm)	
Operating pressure (max.)	350 bar (5100 psi)	
Setting range and pressure ratio	Setting range	Pressure ratio (Rp)
	130÷200 bar (1900÷2900 psi)	1,9
	180÷240 bar (2610÷3480 psi)	2,2
	220÷290 bar (3190÷4200 psi)	2,4
	170÷270 bar (2465÷3915 psi)	2,5
220÷320 bar (3190÷4640 psi)	2,8	
Reaction time	0,2÷0,7 sec	
Tolerance reaction time	± 0,05 sec	
Oil leakage with oil 46 cSt at 40°C	<5cc/min at 80% of pressure setting	
Fluid	mineral based oil	
Viscosity	min.	10 cSt
	max.	200 cSt
Max level of contamination	-/18/14 ISO4406	
Fluid temperature	BUNA N	from -25°C (-13°F) to 90°C (194°F)
	VITON	from -20°C (-4°F) to 200°C (392°F)
Ambient temperature	from -20°C (-4°F) to 60°C (140°F)	
Cavity	SAE 10/2	
Weight	0,20 kg (0.44 lb)	

NOTE - For different conditions please contact our customer service.

MD10M - Dimensions, hydraulic circuit and assembly diagram

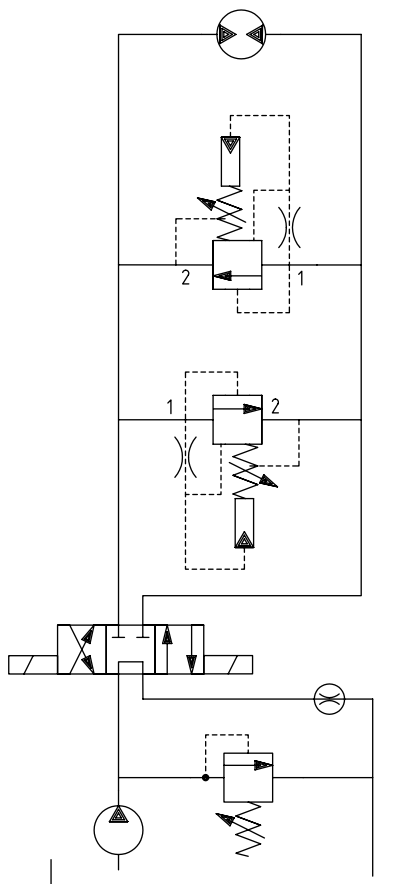

Assembly diagram

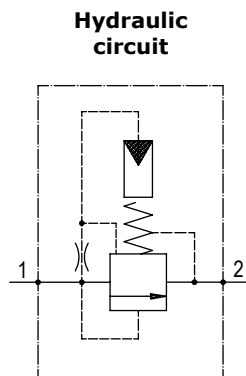

Cavity 10/2 see pag.4

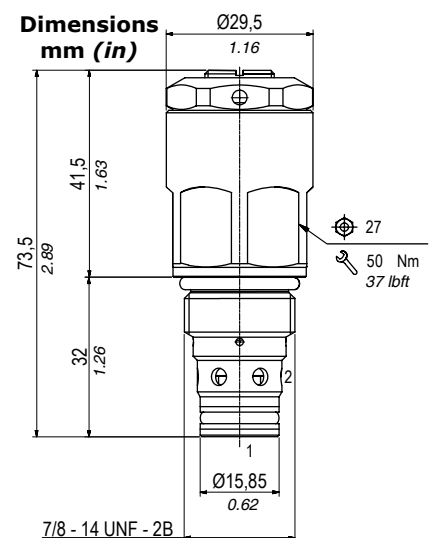

MD10M - Performance data

Performance curve example with typical dimensions

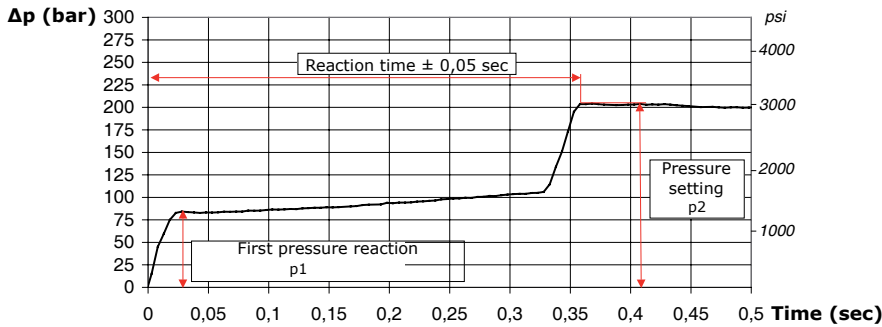

$$\text{Pressure ratio: } R_p = \frac{p_2}{p_1}$$

$$\text{First pressure reaction: } p_1 = \frac{p_2}{R_p}$$

MD10M/□11B - Performance data

Typical pressure drop vs. flow characteristics at max. and min. setting

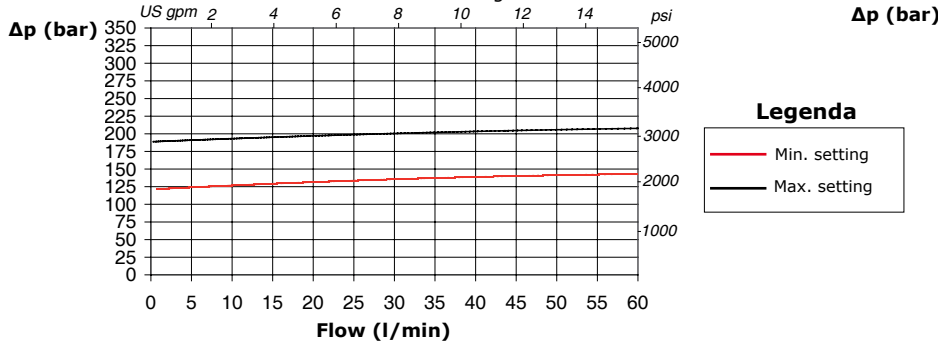

Performance curve at maximum and minimum setting at Q=60l/min

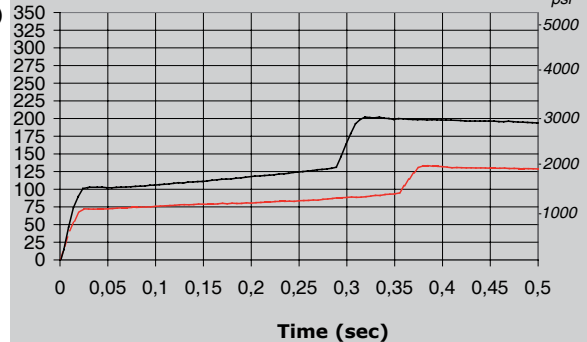

MD10M/□12B - Performance data

Typical pressure drop vs. flow characteristics at max. and min. setting

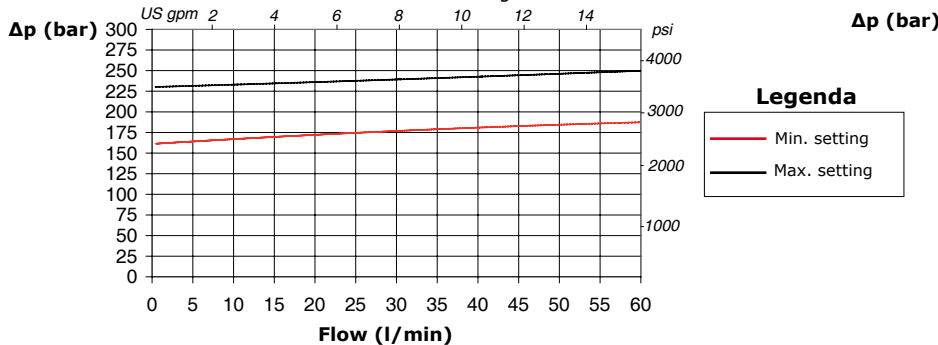

Performance curve at maximum and minimum setting at Q=60l/min

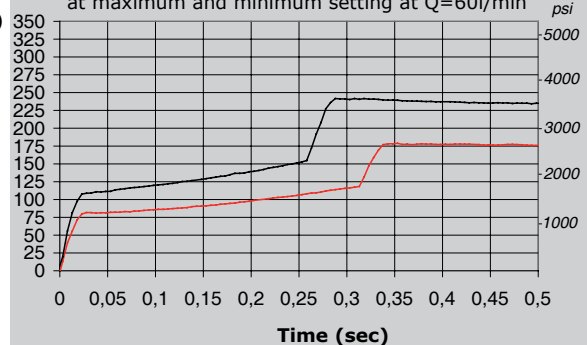

MD10M/□13B - Performance data

Typical pressure drop vs. flow characteristics at max. and min. setting

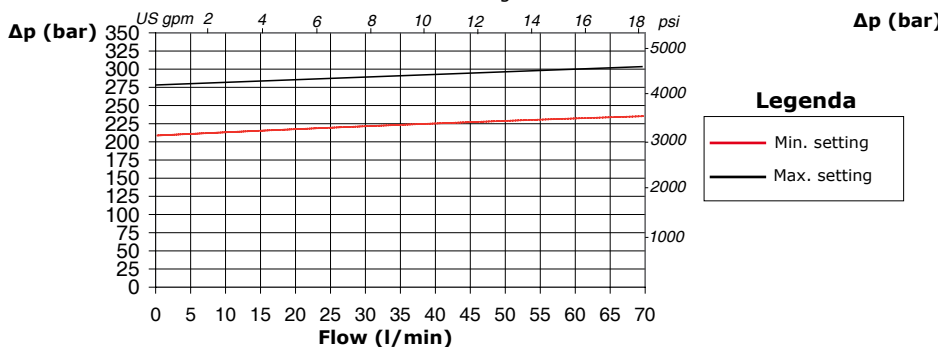

Performance curve at maximum and minimum setting at Q=60l/min

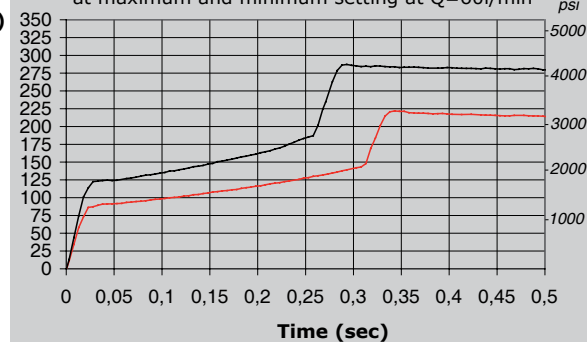

MD10M/□21B - Performance data

Typical pressure drop vs. flow characteristics at max. and min. setting

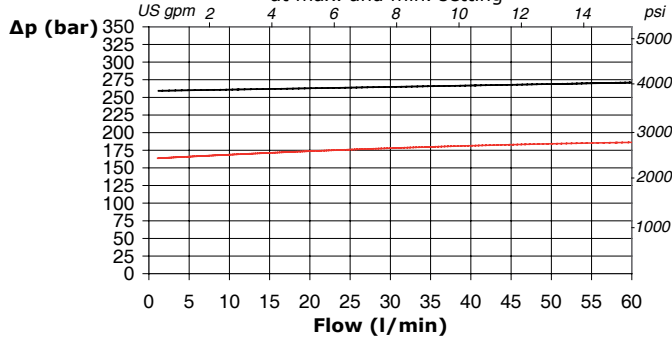

Legenda

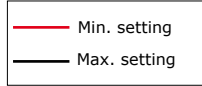

Performance curve

at maximum and minimum setting at Q=60l/min

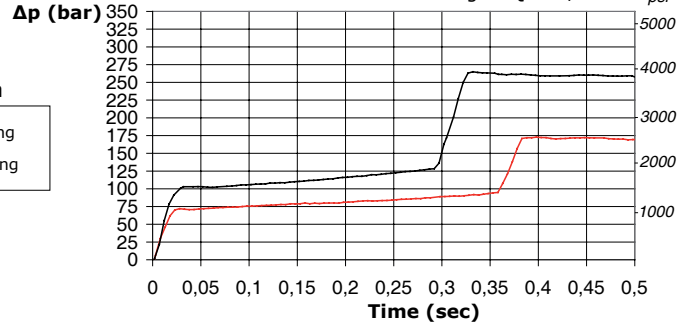

MD10M/□22B - Performance data

Typical pressure drop vs. flow characteristics at max. and min. setting

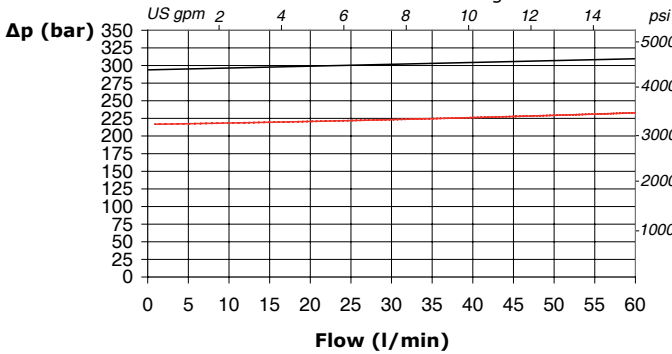

Legenda

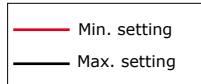

Performance curve

at maximum and minimum setting at Q=60l/min

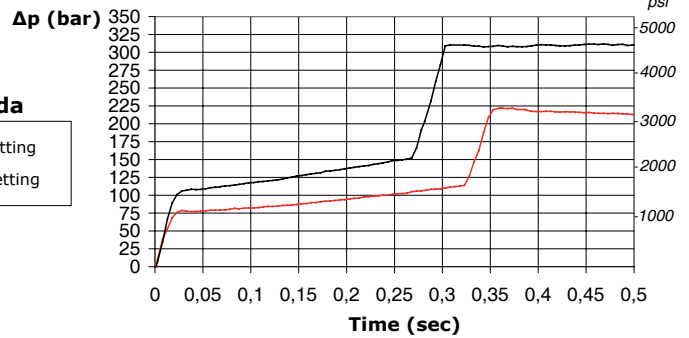

Cavity 10/2

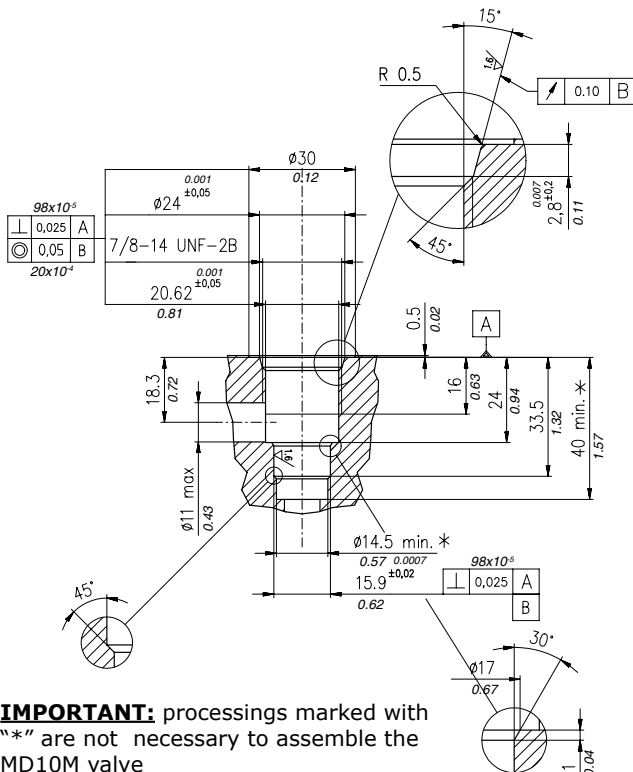

IMPORTANT: processings marked with "*" are not necessary to assemble the MD10M valve

Description composition

MD10M/□ - □ - □ - □

Reaction time

- 2) 0,2
- 3) 0,3
- 4) 0,4
- 5) 0,5
- 6) 0,6
- 7) 0,7

Setting range (bar-psi) and pressure ratio

- 11) 130÷200 (1900÷2900)
Rp=1,9
- 12) 180÷240 (2610÷3480)
Rp=2,2
- 13) 220÷290 (3190÷4200)
Rp=2,4
- 21) 170÷270 (2465÷3915)
Rp=2,5
- 22) 220÷290 (3190÷4640)
Rp=2,8

Seals

- B) Buna
- V) Viton

In the purchase order please specify:
- pressure (p2) and flow setting

Supplied valves are set at the requested pressure and sealed