

NEW

PP10X PP12X

Pressure compensated
flow control valves

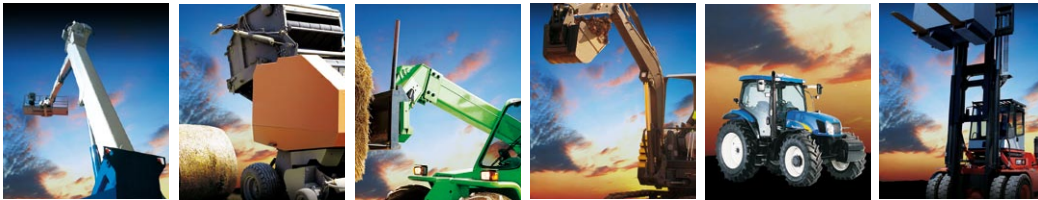

**A simple and flexible solution
for different applications**



PP10X-PP12X Pressure compensated flow control valves

Walvoil is pleased to present the new pressure compensated flow control valves PP10X and PP12X. Thanks to the reduced dimensions these valves are indicated for many applications: agriculture, earth moving machines and industrial vehicles.



- 3 way proportional flow regulator, pressure compensated (spool type solenoid valves)**
- Improved performances**
- Reduced dimensions**

Working conditions

This catalogue shows technical specifications and diagrams measured with mineral oil of 46 cSt viscosity at 40° (104°F) temperature.

	PP10X	PP12X	
Nominal flow rating	port 1	50 l/min - 13.20 US gpm	90 l/min - 23.77 US gpm
	port 3	30 l/min - 7.92 US gpm	55 l/min - 14.53 US gpm
Max. pressure	315 bar - 4600 psi		
Coils type	BQP19		
Oil leakage (210 bar - 3050 psi)	30 cm ³ /min - 1.81 in ³ /mm	50 cm ³ /min - 3.05 in ³ /mm	
Fluid	Mineral based oil		
Nominal current	1.25 A coil 12 V		
	0.63 A coil 24 V		
Advised frequency Dither	150 Hz		
Cavity	SAE10/3	SAE12/3	
Max. level of contamination	18/16/13 ISO 4406		
Thermal insulation class	classe F (155° C) (IEC85-EN60730)		
Safety standards	IP65 (IEC 60529) for coil DIN		
	IP67 (IEC 60529) for coil DEUTSCH		

Note: for different conditions please contact Sales Dpt.

Performance data

PP10X

Flow regulating diagram

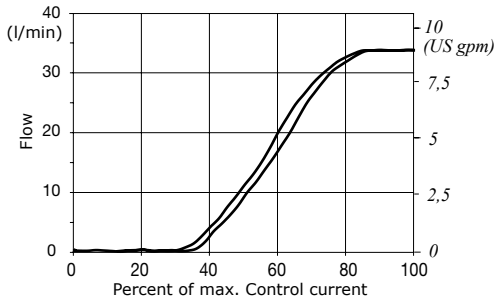

Flow pressure diagram from port 2 ⇒ port 3

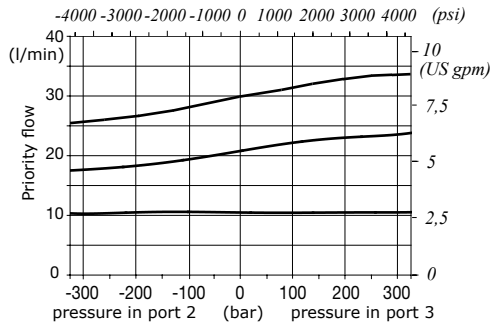

PP12X

Flow regulating diagram

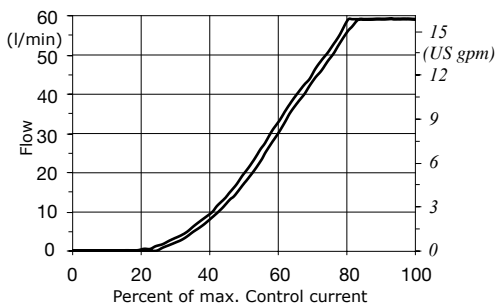

Flow pressure diagram from port 2 ⇒ port 3

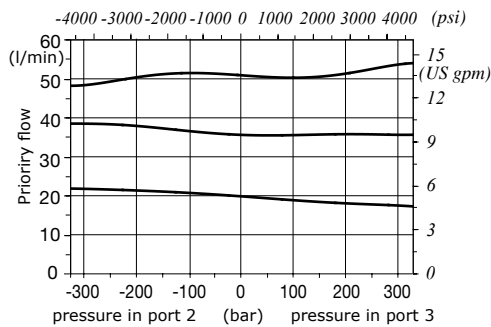

Dimensions

PP10X

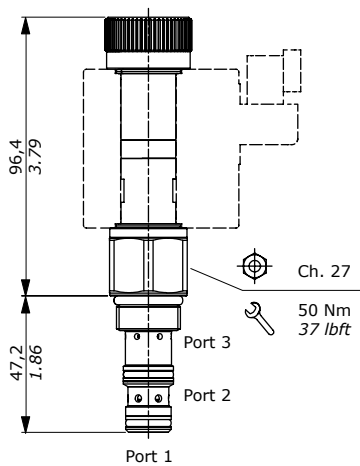

PP12X

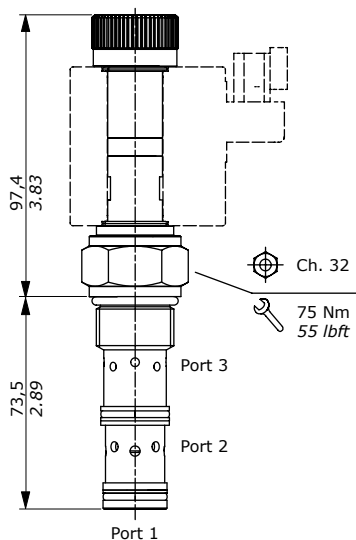

Hydraulic circuit

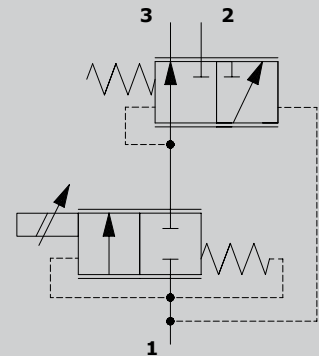

Features

The coils are available with 12VDC or 24 VDC, both with connector DIN and connector DEUTSCH.

In addition to the standard configuration without emergency, we can offer the control with screw emergency and with handknob emergency.

Description composition

PP10X / □ 0 □ - □

**Pressure drop
from 1 to 3 ports**

A) 12 bar / 170 psi

Type of emergency

N) Without (standard)

T) With screw

V) With handknob

Seals

B) Buna

V) Viton

PP12X / □ 0 □ - □

**Pressure drop
from 1 to 3 ports**

A) 12 bar / 170 psi

Type of emergency

N) Without (standard)

T) With screw

V) With handknob

Seals

B) Buna

V) Viton

