

NEW

DPC200

Pressure pre-compensated
Load-Sensing valve

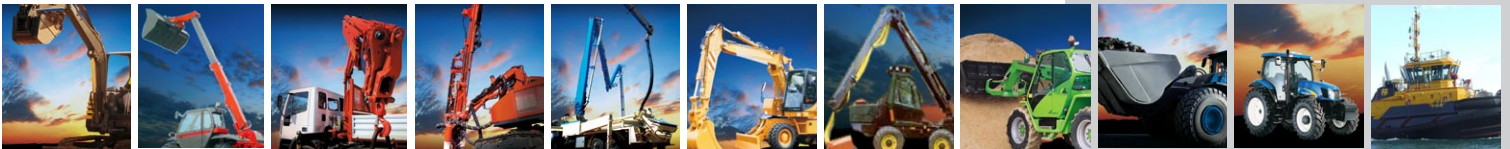

**An effective solution
for high flow**

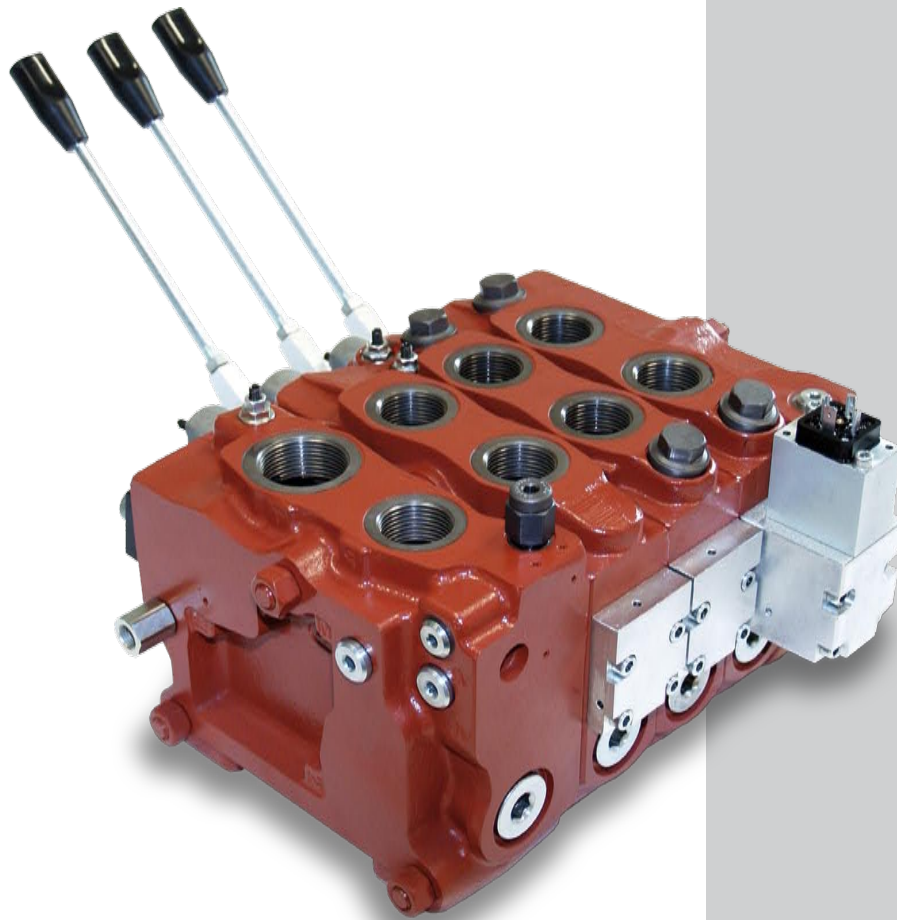

DPC200 Pressure pre-compensated Load-Sensing valves



- Load Sensing technology
- Different types of spools
- For Load Sensing variable displacement pump (closed circuit) or fixed displacement pump application (open centre)
- Manual, hydraulic and proportional electrohydraulic controls
- Up to 10 working sections

Walvoil is pleased to present the new DPC200 Load-Sensing sectional valve, particularly indicated where high flow conditions are required.

Working conditions

Nominal Flow rating	inlet port	260 l/min	68 US gpm
	working ports with compensator	200 l/min	52 US gpm
	working ports without compensator	240 l/min	63 US gpm
Operating pressure (max.)	inlet port P	350 bar	5000 psi
	ports A and B	420 bar	6100 psi
Back pressure (max.)	on outlet port T	25 bar	360 psi
Internal leakage A(B)->T	$\Delta p=100 \text{ bar}-1450 \text{ psi}$ fluid and valve at $40^{\circ}\text{C}-104^{\circ}\text{F}$	Without port valves	Without port valves
		With port valves	With port valves
Fluid		Mineral based oil	
Fluid Temperature	with NBR (BUNA-N) seals (FPM on request)	from -20°C to 80°C	from -4°F to 176°F
Viscosity		from 12 to 400 mm ² s	from 12 to 400 cSt
Max. contamination level		18/16/13 - ISO 4406	
Ambient temperature for working conditions	with mechanical and hydraulic devices	from -40°C to 60°C	from -40°F to 140°F
	with electric devices	from -20°C to 60°C	from -4°F to 140°F

Note: for different conditions, please contact Walvoil Sales Dpt.

Standard threads – reference standard

Ports	BSP	UN-UNF
THREAD ACCORDING TO	ISO 228/1	ISO 263
	BS 2779	ANSI B1.1 unified
CAVITY ACCORDING TO	ISO 1179	11926
	SAE	J1926
	DIN 3852-2 shape X or Y	

MAIN PORTS	BSP	UN-UNF
Inlet P	G 1	1 5/16-12 (SAE16)
Ports A and B	G 1	1 5/16-12 (SAE16)
Outlet T	G 1- 1/4	1 5/8-12 (SAE20)
Pilot V1	G 1/4	7/16-20 (SAE4)
Drain L	G 1/4	9/16-18 (SAE6)

Note: SAE3000 flanging on request: contact Walvoil Sales Dpt.

NEW

Dimensions

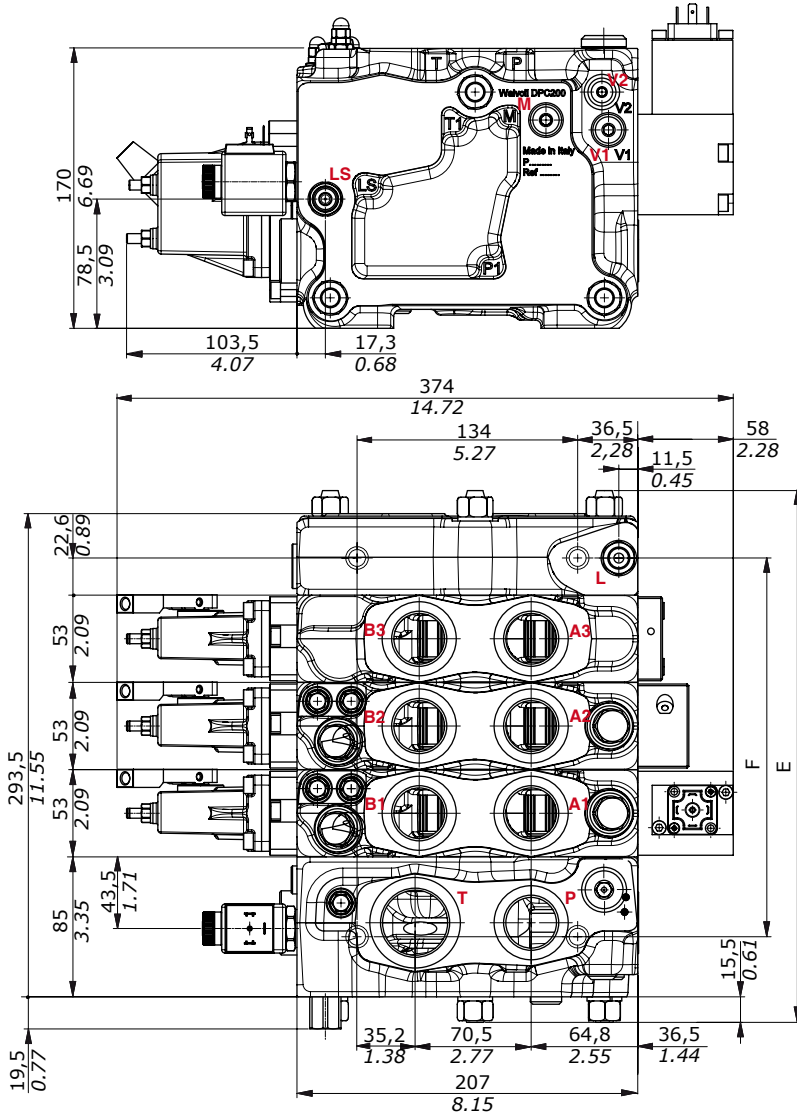

TYPE	E		F	
	mm	in	mm	in
DPC200/1	217	8.54	124	4.88
DPC200/2	270	10.63	177	6.97
DPC200/3	323	12.72	230	9.05
DPC200/4	376	14.80	283	11.14
DPC200/5	429	16.89	336	13.23
DPC200/6	482	18.98	389	15.31
DPC200/7	535	21.06	442	17.40
DPC200/8	588	23.14	495	19.49
DPC200/9	641	25.24	548	21.57
DPC200/10	694	27.32	601	23.66

NOTE: Drawings and dimensions refer to BSP thread configuration

Hydraulic circuit

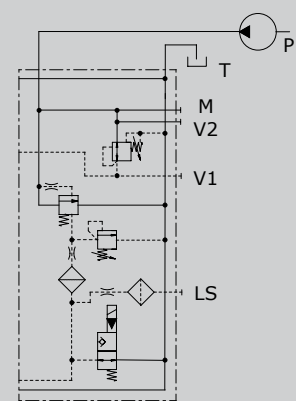
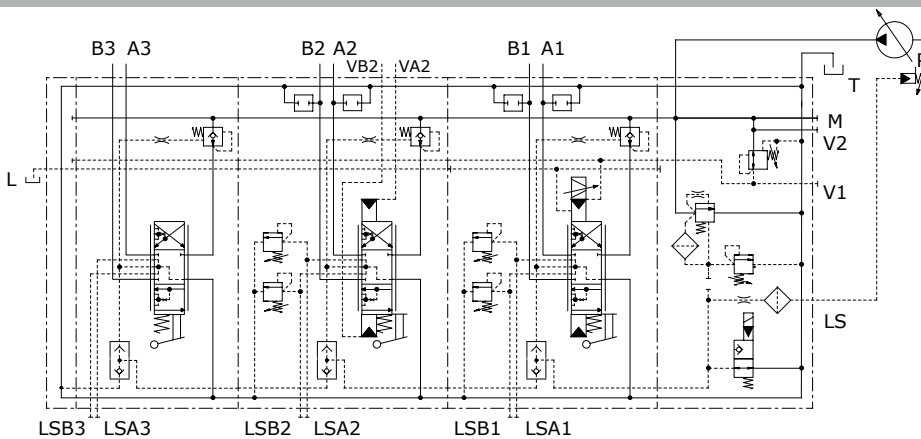

Performance data

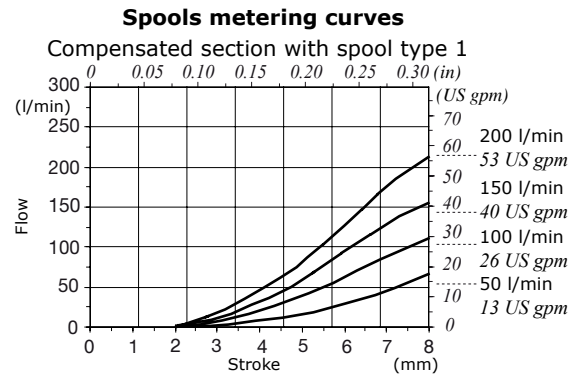
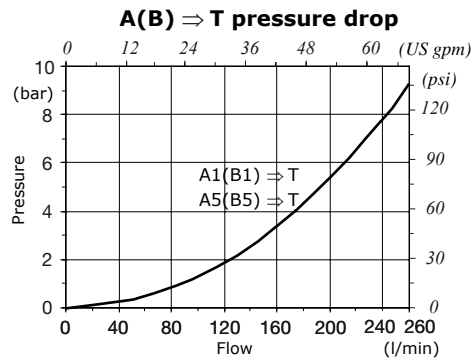
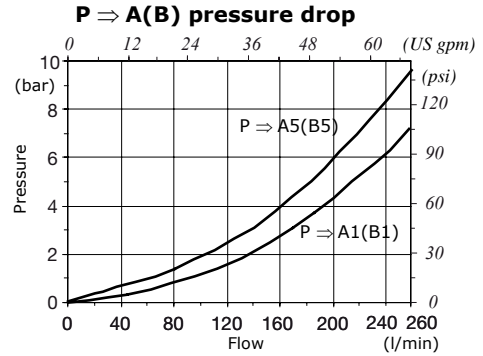
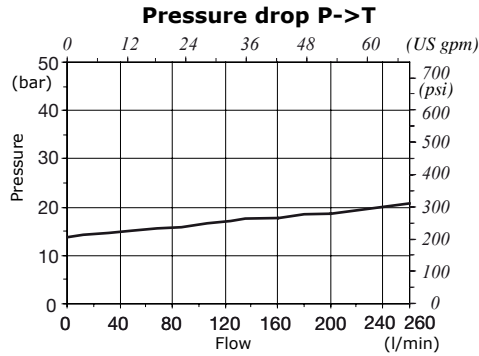

Features

The main feature of Load Sensing principle is that the flow rate to the user is proportional to the spool position under any operating condition, regardless of the resistance encountered by the user (pressure) and the number of levers activated (limitation of pump flow rate).

Moreover the L.S. system offers the following advantages:

- energy saving
- long lasting components
- noise reduction.

Applications

Marine applications, mixer, dumpers, telehandlers, fork lifts, waste compactors, excavators, truck mounted cranes, all terrain cranes, agricultural and forestry machines, drilling machines, wheel loaders, hydraulic trailers, container handling.

Configurations and options

Inlet section options:

- for both fixed displacement pump and LS variable displacement pump
- main relief valve on LS signal
- unloader valve on LS signal

Working section:

- with or without compensator
- optional port relief valves
- optional relief valve on L.S. signal (A, B ports with different settings)

Outlet section options:

- external/internal drain option

