



**walvoil**  
MOTION BY PEOPLE

**NEW**

## DPK120

Pre-compensated Sectional Valve  
for Tractor and implements

### DPK120 VALVE

- New Load Sensing valve for all Tractor sizes
- High energy efficiency
- Integrated Hitch Control
- Compatible with all Walvoil electronic systems
- CANbus electro-hydraulic module

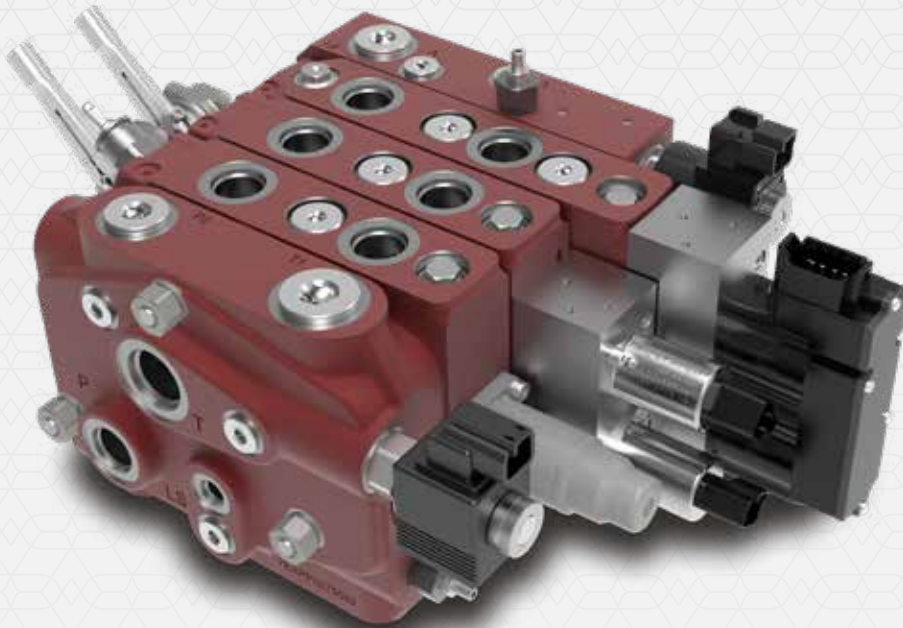

In recent years, the agricultural sector has evolved rapidly towards modern machines that present increasingly sophisticated technological solutions. In particular, the latest generation of tractors is made with the aim of offering high performance and functionalities with solutions of high energy optimization, that comply with international safety regulations.

The new Walvoil DPK120 has been specially designed to meet all these requirements. It is a pre-compensated sectional valve for open/closed center circuits, designed specifically for tractors and implements.

It is equipped with a wide and flexible range of options and elements, to meet all needs: a general input compensator for energy optimization (on open center configuration), working sections with zero-leakage block valves, fully configurable with manual, hydraulic, electro-hydraulic proportional controls (also available in NG5 CANbus module version).

## WORKING CONDITIONS

Technical specifications and diagrams measured with mineral oil of 46 mm<sup>2</sup>/s (46 cSt) viscosity at 40°C - (104°F) temperature.

<b>Nominal flow rating</b>	On inlet	180 l/min - 47.5 US gpm
	On ports	120 l/min - 32 US gpm
<b>Max. pressure</b>		250 bar - 3600 psi
<b>Fluid</b>		Mineral oil-based
<b>Fluid temperature range</b>	With NBR seals (BUNA-N)	from -20°C to 100°C from -4°F to 212°F
	Operating range	from 15 to 75 mm <sup>2</sup> /s from 15 to 75 cSt
<b>Viscosity</b>	Min.	12 mm <sup>2</sup> /s - 12 cSt
	Max.	400 mm <sup>2</sup> /s - 400 cSt
<b>Max. contamination level</b>		-/18/15 - ISO 4406 NAS 1638 - class 9
	With mechanical, hydraulic and pneumatic devices	from -40°C to 60°C from -40°F to 140°F
<b>Environmental temperature for working conditions</b>	With electric devices	from -30°C to 60°C from -22°F to 140°F
	With electro-hydraulic devices	from -20°C to 80°C from -4°F to 176°F

PORT THREADING			
MAIN PORTS	BSP	METRIC (ISO 262)	UN-UNF
<b>P</b> inlet	G 3/4	M27x2	1" 1/6-12 (SAE 12)
<b>A</b> and <b>B</b> ports	G 1/2	M22x1.5	7/8-14 (SAE 10)
<b>T</b> outlet	G 3/4	M27x2	1" 1/6-12 (SAE 12)
PILOT PORTS			
<b>V</b> and <b>L</b> ports	G 1/4	M12x1.5	9/16-18 (SAE 6)

**DIMENSIONAL DATA**

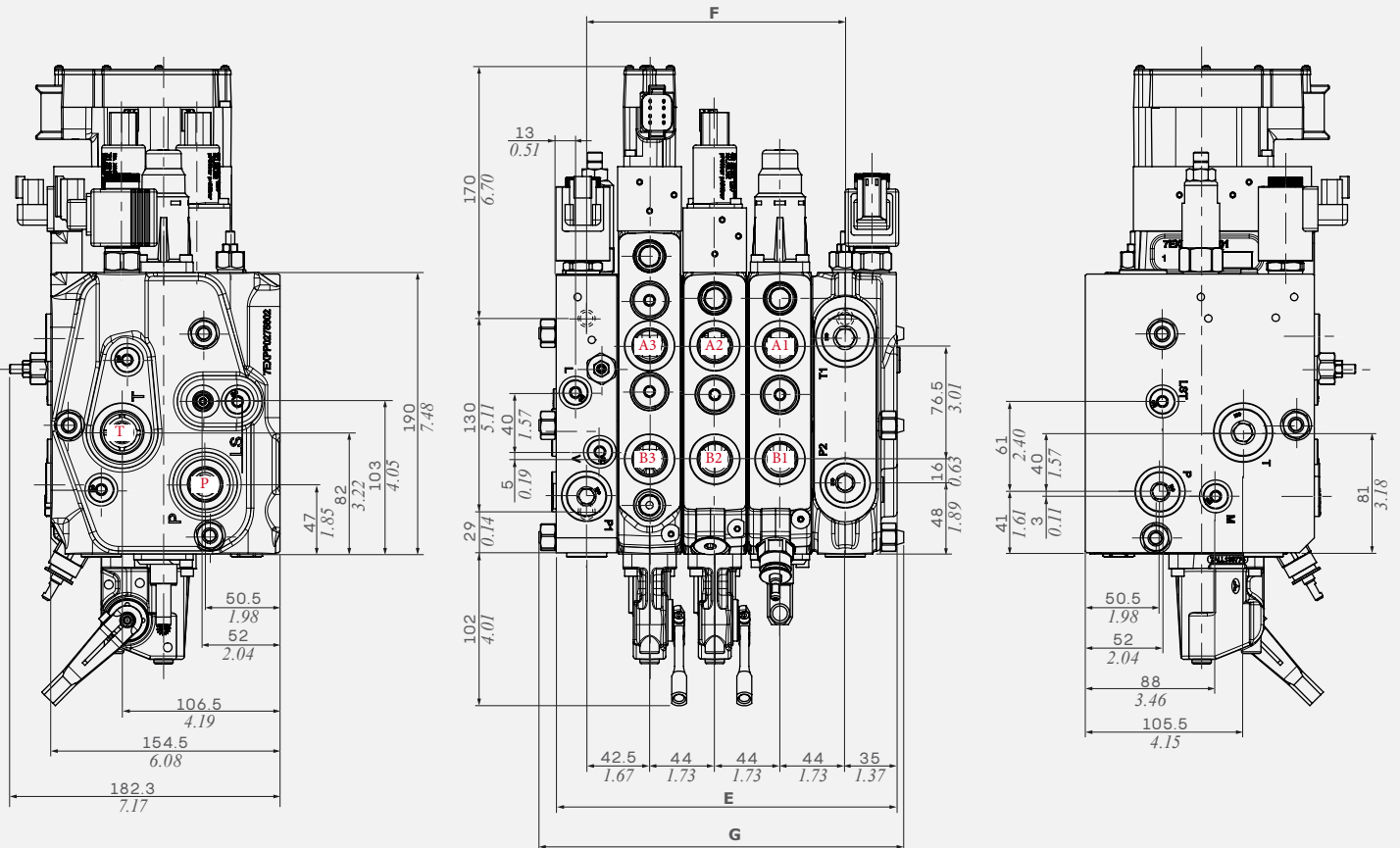

Type	E		F		G	
	mm	in	mm	in	mm	in
DPK120/1	142	5.59	121.5	4.78	159	6.26
DPK120/2	186	7.32	165.5	6.52	203	7.99
DPK120/3	230	9.06	209.5	8.25	247	9.72
DPK120/4	274	10.79	253.5	9.98	291	11.46
DPK120/5	318	12.52	297.5	11.71	335	13.19
DPK120/6	362	14.25	341.5	13.44	379	14.92
DPK120/7	406	15.98	385.5	15.18	423	16.65
DPK120/8	450	17.72	429.5	16.9	467	18.39
DPK120/9	494	19.45	473.5	18.64	511	20.12
DPK120/10	538	21.18	517.5	20.37	555	21.85

**P→T Pressure drop inlet compensator (margin pressure)**

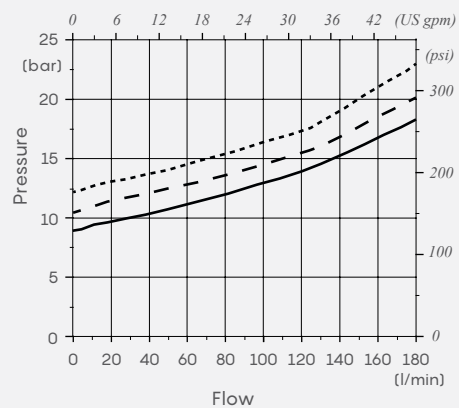

- 12.5 bar (181.2 psi)
- - - 10.5 bar (152.2 psi)
- 9 bar (130.8 psi)

## HYDRAULIC CIRCUIT

### Example of Closed circuit

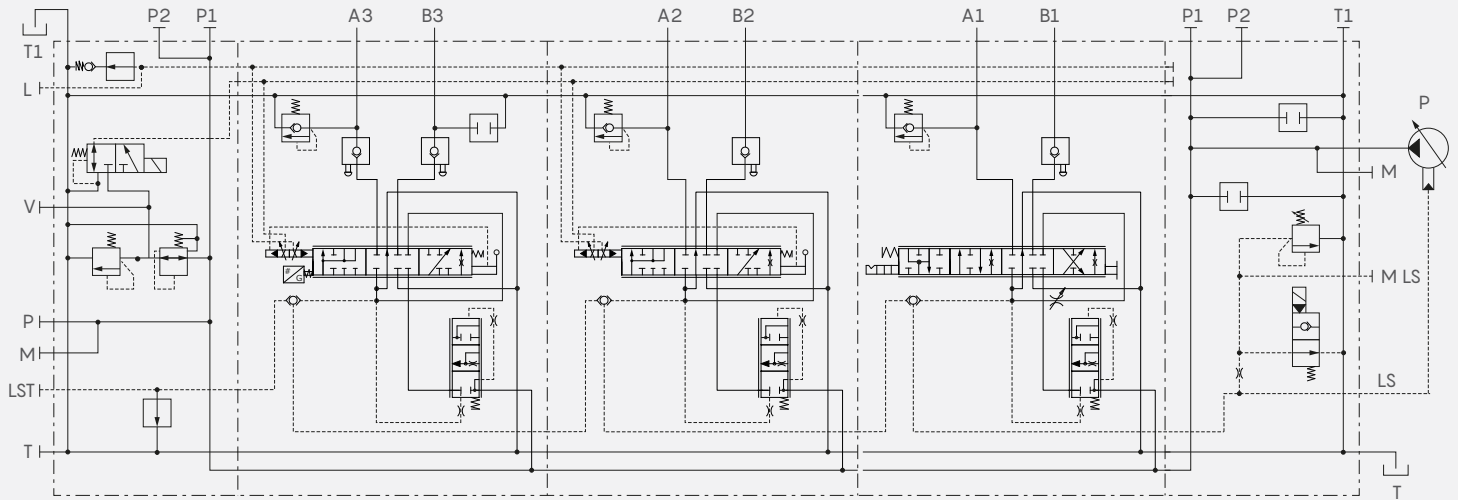

## PERFORMANCE DATA

**Pressure vs. flow diagram**

LS→A1 - B1→T / LS→A7 - B7→T

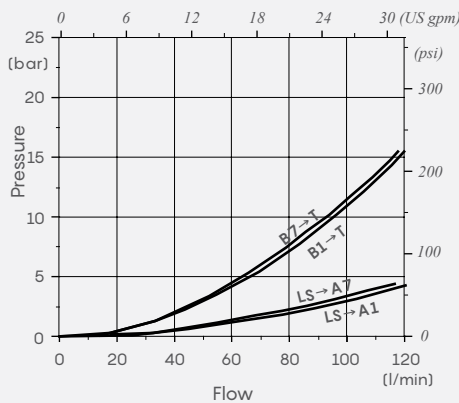

**Pressure vs. flow diagram**

LS→B1 - A1→T / LS→B7 - A7→T

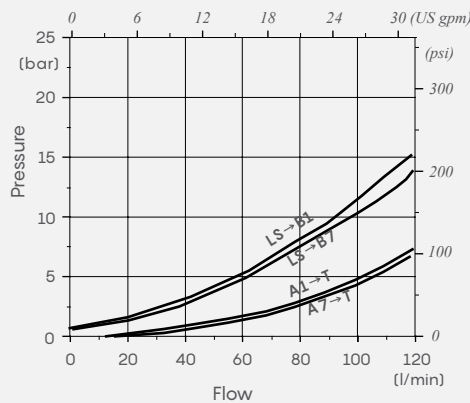

**Compensated working section**

$Q_{in} = 130 \text{ l/min (34.3 Us gpm)}$   
Stand-by = 13.5 bar (195.7 psi)

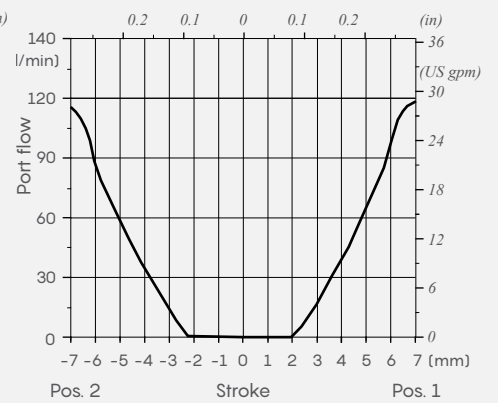

Note: Values represent zero-leak valve configuration only on B ports.

**WORKING SECTION CONFIGURATION: EXAMPLE**

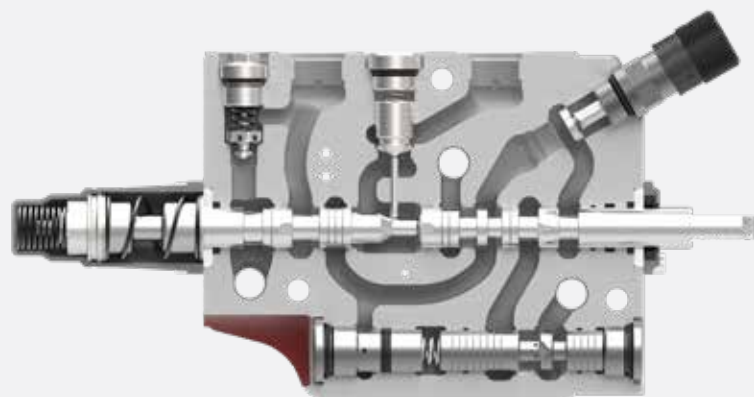

- Single zero-leak valve
- Manual control
- Flow control
- Auxiliary valve

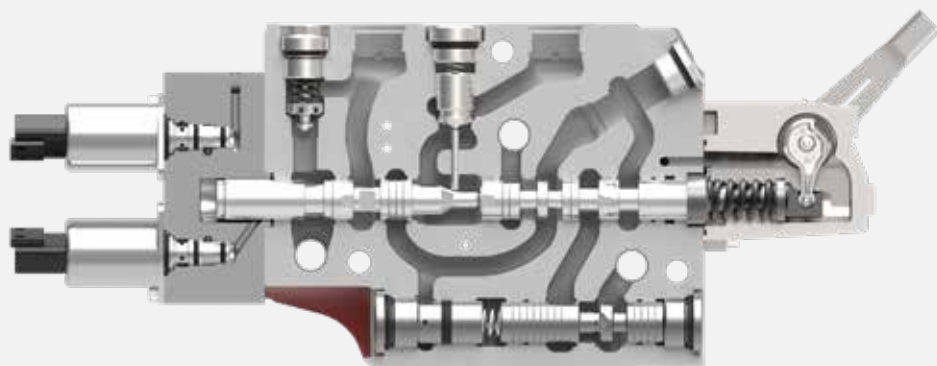
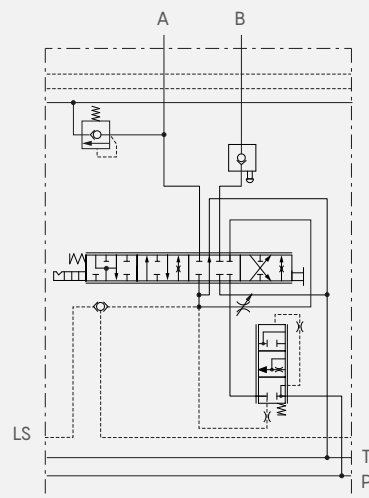

- Single zero-leak valve
- PWM electro-hydraulic control
- Auxiliary valve

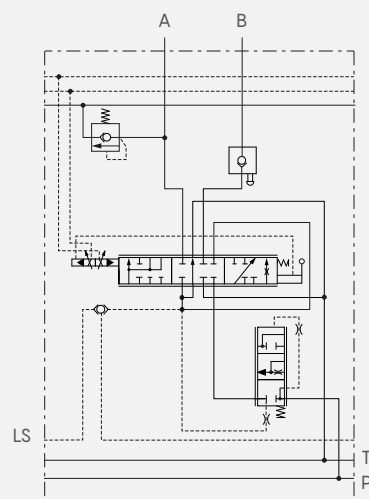

**WORKING SECTION CONFIGURATION: EXAMPLE**

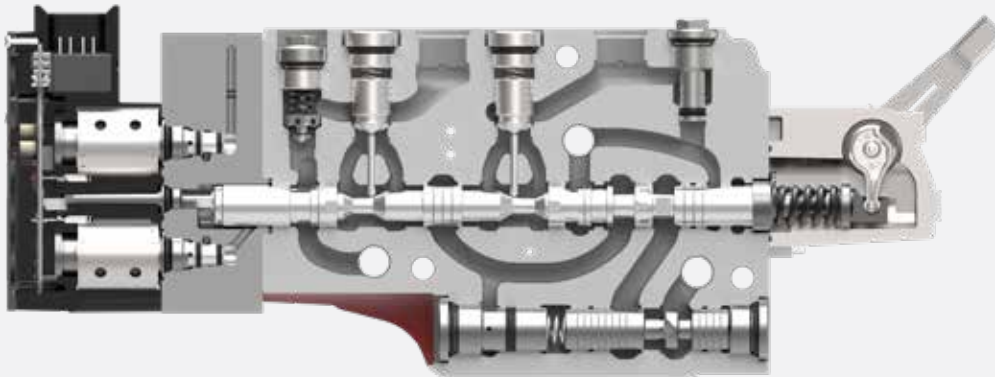

- Double zero-leak valve
- NG5 CANbus electro-hydraulic control
- Auxiliary valve

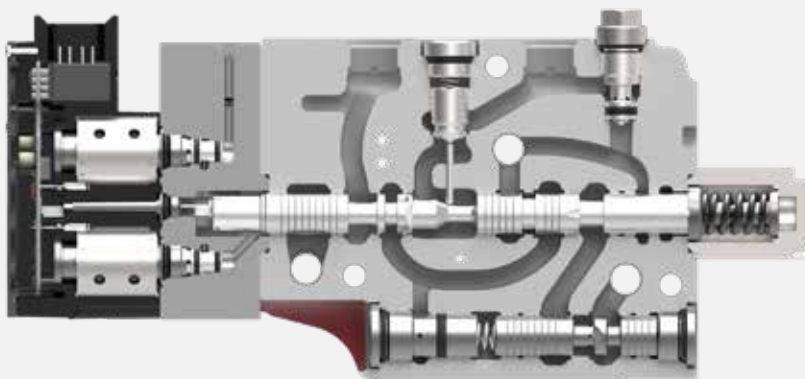
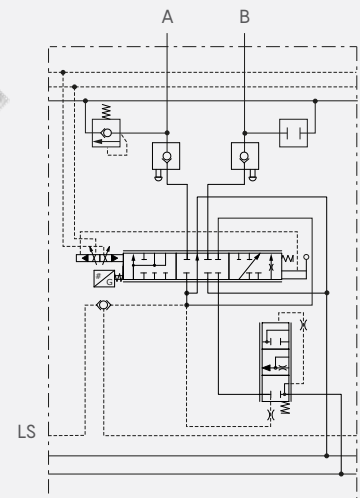

- Hitch Control
- Single zero-leak valve
- NG5 CANbus electro-hydraulic control
- Auxiliary valve

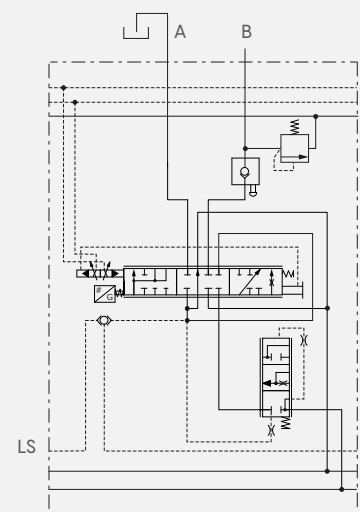

## HITCH CONTROL SYSTEM

Walvoil automated electro-hydraulic Hitch Control system allows the control of the towed or pushed implements on the tractor, replacing manual adjustment with efficient and precise management.

All adjustments, which compensate for unexpected changes in ground conditions, are performed by the operator directly in the cabin; this working mode offers an automated and optimized control of machine performances and guarantees a higher level of operator safety.

Walvoil Hitch Control counteracts oscillations of the attachment during the moving phase, reducing wear and making transport more comfortable for the driver.

The system therefore allows control solutions that contribute to make the machines more competitive by improving operator safety, comfort and productivity.

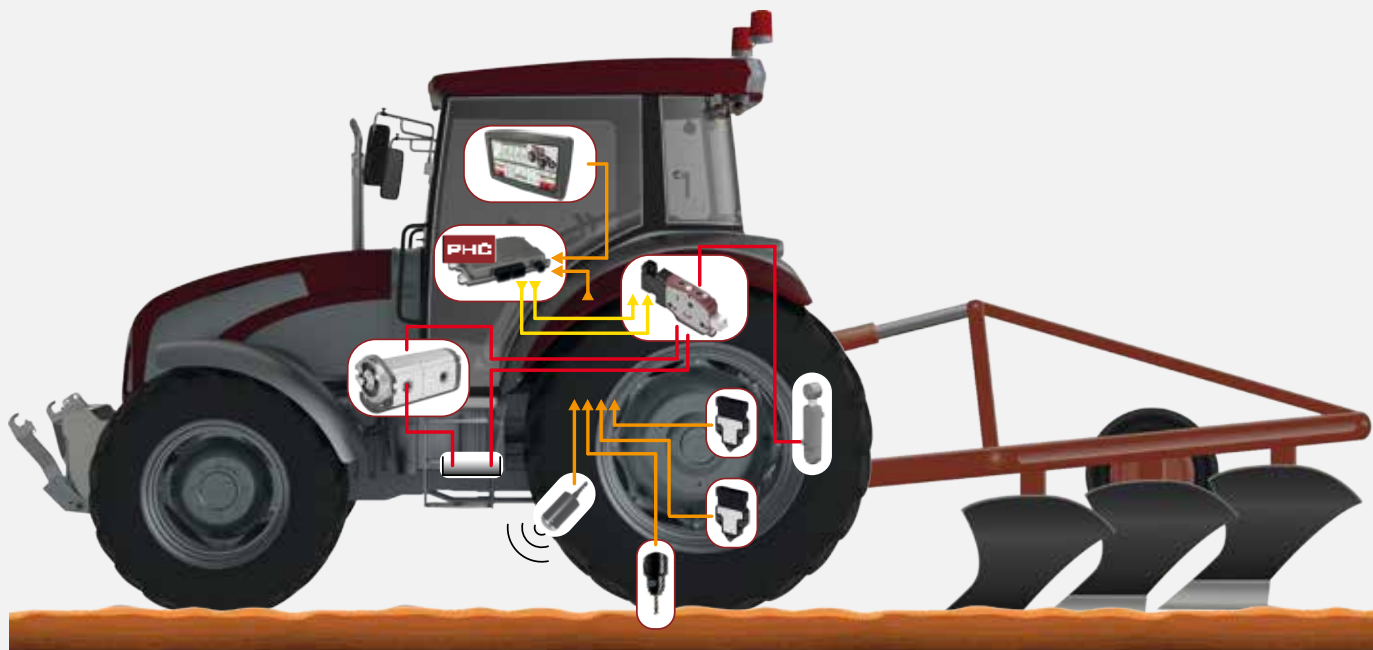

## HITCH CONTROL SYSTEM

Walvoil offers 3 Hitch Control system levels to meet the different customer needs:

• **Base Solution**

It includes only DPK120 sectional valve with integrated Hitch Control.

• **Intermediate Solution**

Closed loop complete system including, in addition to DPK120 valve, the CED1200S or CED400W ECUs fitted with PHC Studio Suite.

• **Advanced Solution**

It's the most complete proposal including the same products as the Intermediate Solution, with customizable display, angle and draft sensors.

Devices	Type of solutions		
	Base	Intermediate	Advanced
DPK120 Sectional valve	•	•	•
CED1200S or CED400W ECUs		•	•
Display			•
Sensors			•

