



walvoil
MOTION BY PEOPLE

NEW

ALS – Adaptive Load Sensing

From an Adaptive Load Sensing
to Adaptive System Architecture



ALS ADAPTIVE SYSTEM ARCHITECTURE

Hydraulic systems represent the core actuation of many construction machinery. This technology is well established in the market and is well known to be reliable and cost effective. Several mechanical control systems have been developed in the last century, relying on pure mechanical regulators and controllers. Walvoil introduces a new generation of control systems based on electronic circuit and algorithms. An advanced software allows better operation performance and dissipation reduction.

ALS Adaptive System is not anymore only a Load Sensing management system, but it is a system architecture combining products and applications through mechanical and digital parameters.

It allows the optimization of the critical parameters.

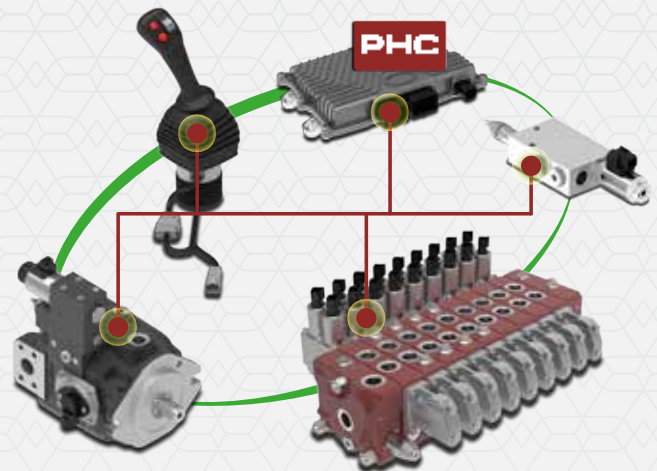

ADVANTAGES

- Synergistic set of components for the efficiency of mobile machines.
- Pressure Margin reduction both during operation and machine inactivity phases.
- Definition of easily customizable control and sensitivity curves using PHC STUDIO software.
- Definition of different operating conditions for maximizing control or productivity.
- Dynamic torque and power limitation.
- Greater utilization of installed power.
- Less fluid heating.
- Less instability and oscillations.
- Customizable actuation modes for more comfortable driving.



TYPE OF SOLUTIONS

Walvoil offers three different ALS solutions to provide extreme versatility and adapt to the performance and system requirements of the machine. In fact, the ALS system can be used as an integral part of the hydraulic directional control valve or fitted to the variable displacement pump.

- LS Electronic Control
- Electronic Flow Control
- Electric Power Flow Control

LS ELECTRONIC CONTROL

This solution enables to use Pressure Control functions combined with Flow Sharing directional control valves of the DPX and EPX (CONCEPT DESIGN) series. The system manages and conditions the Load Sensing signal of the circuit in order to reduce consumption and optimize control.

Since the ALS system can be fitted directly to the directional control valve, its benefits can be enjoyed combined with fixed displacement pumps.

Architecture example

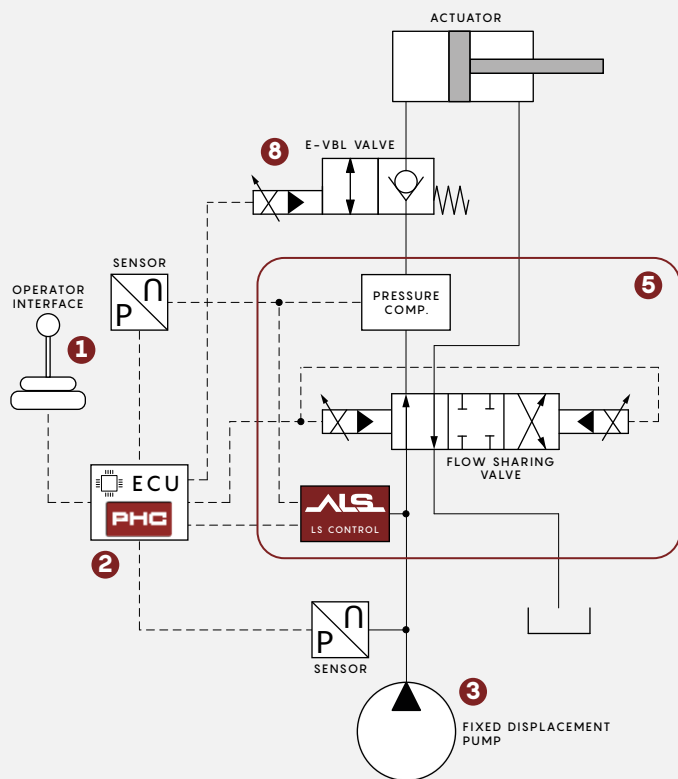

Architecture features

- Variable pump margin.
- Low energy idle.
- Flow regulation curve modelling.
- Retrofit.

Products example

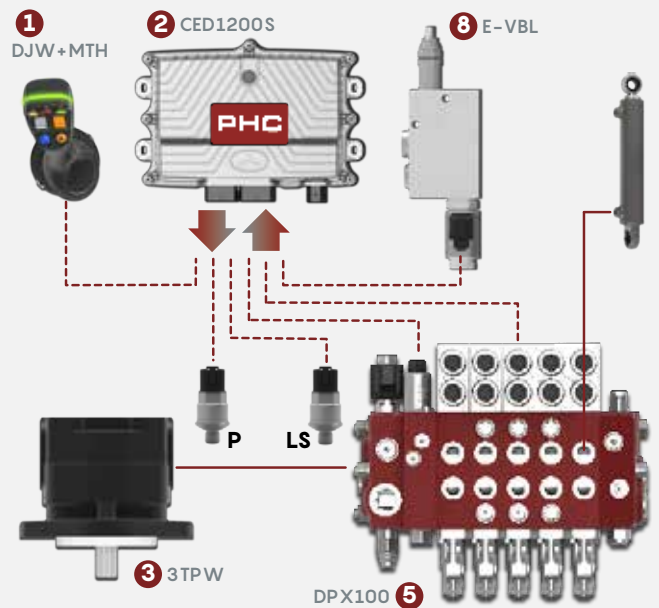



ELECTRONIC FLOW CONTROL

Load Sensing version

In case the DPX or EPX (CONCEPT DESIGN) valve is combined with a Variable Displacement pump, the ALS regulator with Flow Control is integrated into the pump which, with this solution, provides the defined flow rate, both according to the logic set by the operator and through the target values defined through the signals coming from the various sensors.

Architecture features

- Variable pump margin.
- Low energy idle.
- Flow regulation curve modelling.
- Torque/Power control.
- Energy saving.
- Priority function.
- Max flow function.
- Dynamic responsiveness.

Architecture example

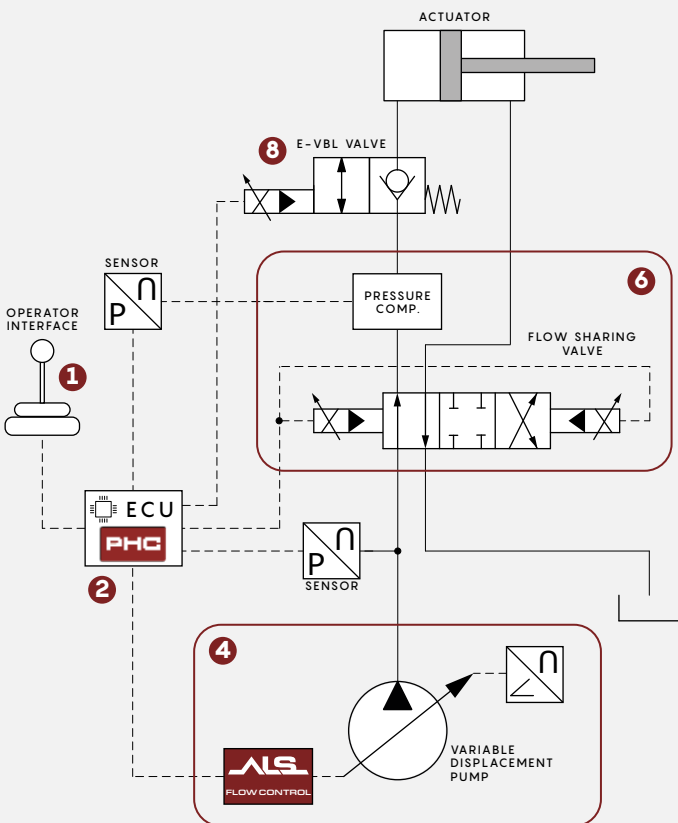

Products example

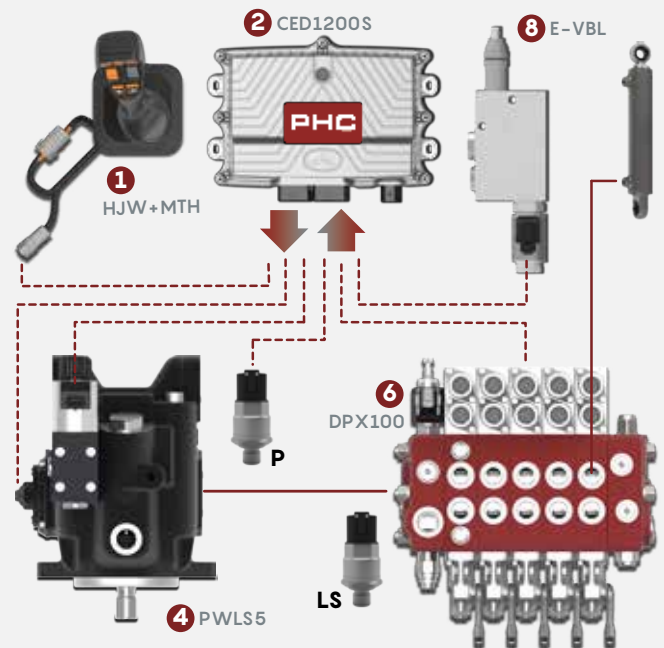



ELECTRONIC FLOW CONTROL

Open Center version

The special feature of this configuration is the combination of a normal electro-proportional Open Center directional control valve with the electronically controlled variable displacement pump equipped with ALS logic.

The Variable Displacement pump supplies the flow demand settled by the operator logic (dedicated software), accordingly with single or multiple operations. In this configuration the Flow on Demand Logic ensures better load metering and greater vehicle stability combined with a tangible reduction in fuel consumption.

The system is managed by an electronic control unit and specially developed software in the PHC STUDIO environment.

Architecture features

- Low energy idle.
- Torque/Power control.
- Energy saving.
- Max flow function.
- Dynamic responsiveness.

Architecture example

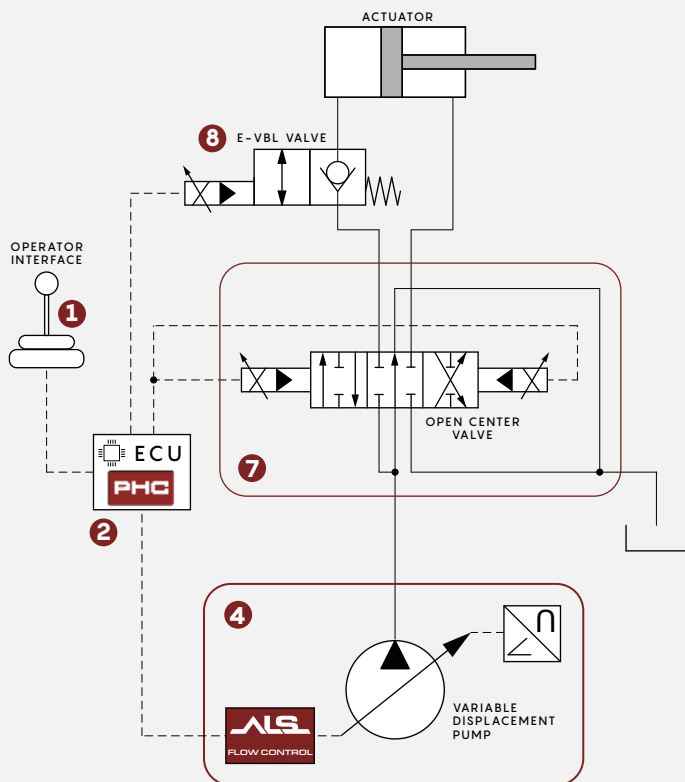

Products example

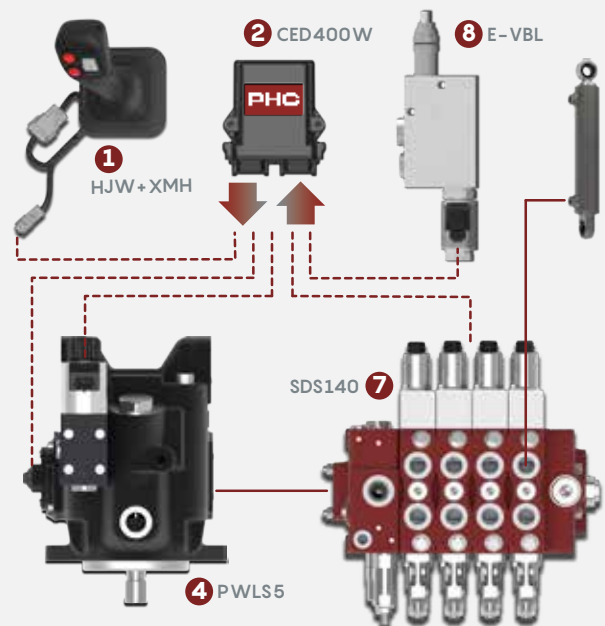



ELECTRIC POWER FLOW CONTROL

Where sustainability, energy saving, silence are the essential values, the partial or complete electrification of Mobile Machines becomes an increasingly appreciated solution.

The Electric Power Flow Control combines a Low Noise pump with a variable speed electric motor to obtain efficient and silent power management.

The operator interface and the Electronic Control Unit constantly communicate with the machine ECU; the required flow rate is controlled by AC motor speed regulation in a closed-loop control system that requires no additional sensors in the hydraulic system.

The Open Center valve completes the system in a simple and efficient way.

Architecture features

- Flow on demand
- Energy efficiency
- Simple integration into existing circuits.
- High flexibility.
- Less fluid heating.
- Less instability and oscillations.
- Low noise emission.

Architecture example

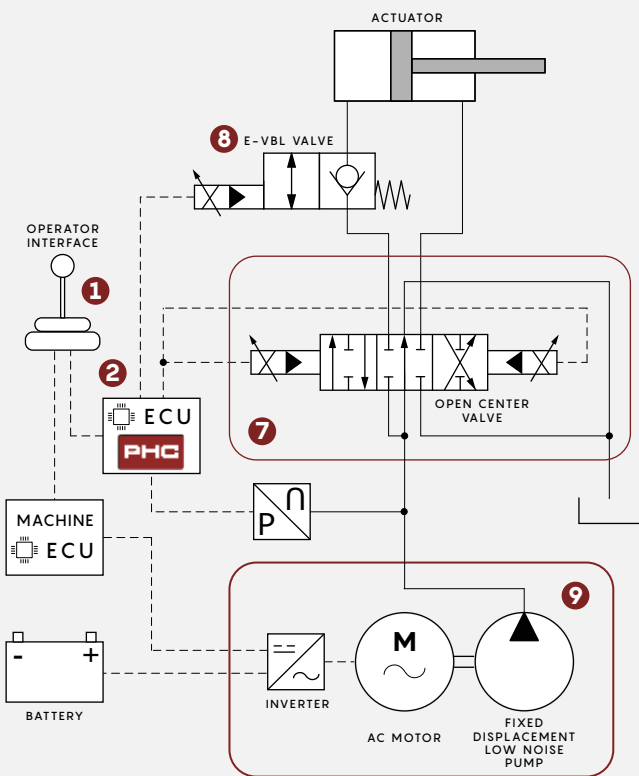

Products example

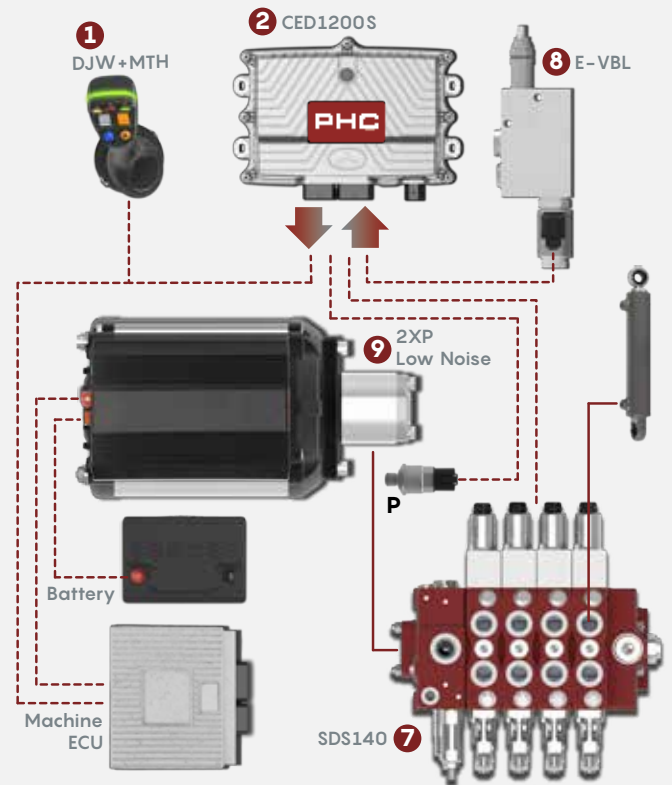



ARCHITECTURE FEATURES

Variable pump margin

The joint control of the hydraulic directional control valve and the pump makes it possible to cut down pressure drops due to the pressure margins of the metering system.

The software basically includes several automatic functions:

- Selection of the maximum efficiency conditions.
- Power limitation management to ensure full exploitation of the engine characteristic curve.
- Automatic reduction of stand-by pressure in the inactivity phases of the auxiliary functions.

The **Precision** function reduces the Pressure Margin value, allowing to improve the accuracy and sensitivity of operation.

The **Boost** function temporarily increases the Pressure Margin value for higher speeds and productivity, without the need to install larger pumps.

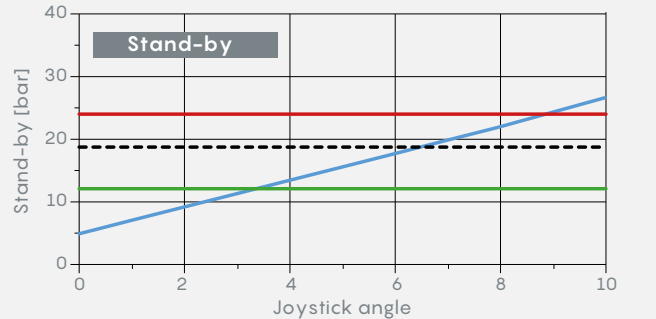

— Boost — Custom — Precision - - - Standard

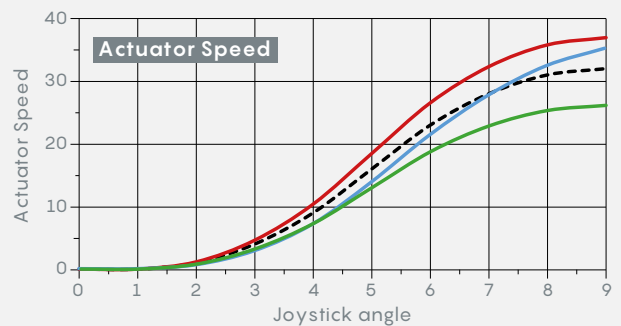

Low energy idle

Idle mode is activated by releasing Deadman push-button. When the machine is not operated the Stand By pressure is adjusted to a minimum value in order to save energy; during inactivity there is a reduction in energy consumption thanks to the adjustable ΔP .

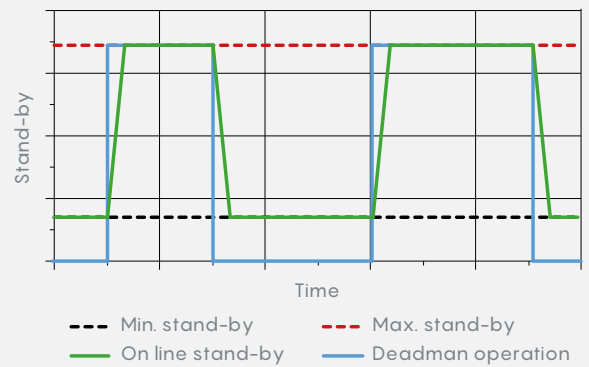

Torque control

A limit torque map can be uploaded in the ECU, contiously adjusted based on the engine RPM.

The electronic system is designed to control the instantaneous torque with a reasonable offset and it can perform a reliable power limitation function.

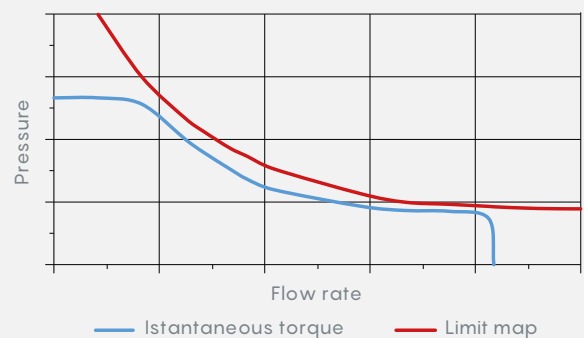



OPERATIVE FUNCTIONS

Priority function

A priority function can be defined through the ALS software. The delivered flow of the priority function is not affected by simultaneous secondary functions, also in case of pump saturation.

With priority function the operator can drive a predetermined actuator without any reduction in terms of speed. The reduction of the flowrate of the other functions is not fixed, but is based on the piloting of priority function and on total displacement available.

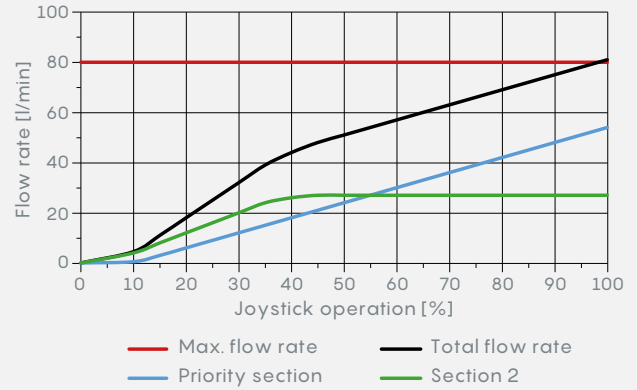

Max flow function

Through the ALS software it is possible to set the delivery curve of any function: the maximum flow can be set through a combination of adjustable Stand-By and valve spool stroke.

Via HMI it's possible to set a limit in terms of velocity of actuator.

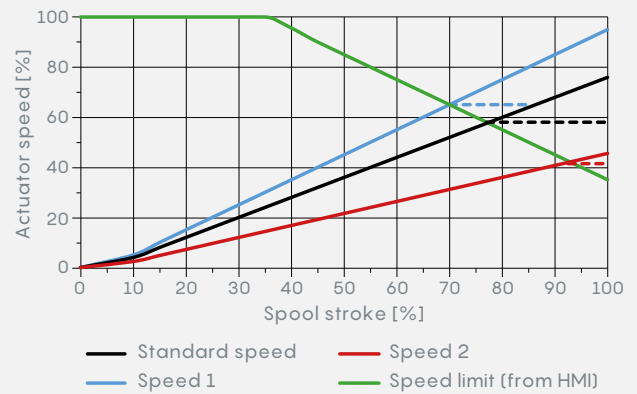

Dynamic responsiveness

The electronic displacement control allows to set different response times, in order to modify the dynamic of the actuators and the operator's feeling.

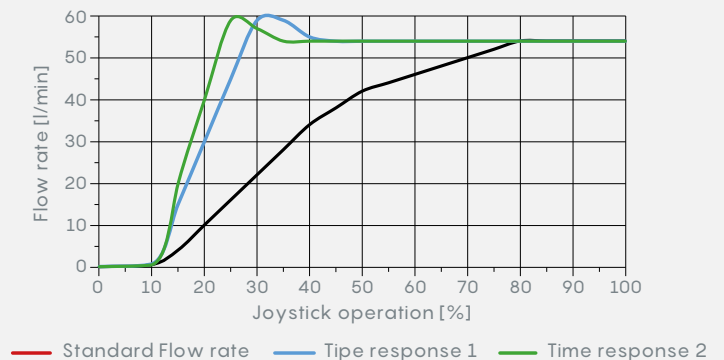

Flow on Demand

This function controls the flow rate or speed of the pump. The sum of the actuator flows corresponds to the target flow rate of the pump, which is directly converted into a speed.

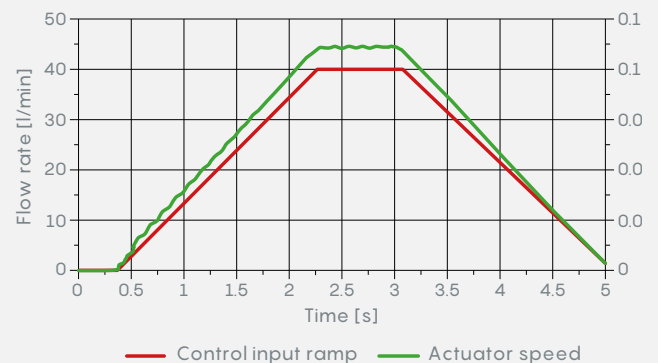

SYSTEMS AND PRODUCTS COMPATIBILITY SUMMARY

ALS main products combination		
Solutions	Pump type	Valve type
LS Electronic Control	Fixed Displacement pump	Flow Sharing Open Center valve EPX valve (CONCEPT DESIGN)
Electronic Flow Control	Variable Displacement pump	Flow Sharing Closed Center valve EPX valve (CONCEPT DESIGN) L.S. Pre-Compensated valve Open Center valve
Electric Power Flow Control	Fixed Displacement pump	Flow Sharing valve EPX valve (CONCEPT DESIGN) L.S. Pre-Compensated valve Open Center valve

