



walvoil

MOTION BY PEOPLE

Titan Series Gear Pumps & Motors



Titan

POWER



PHC



PUMPS & MOTORS

Titan Series introduction

3TPW pump and 3TMW motor configurations

New range of 3TPW Cast Iron Pumps and 3TMW Cast Iron Motors.

These pumps and motors are particularly suitable for all applications where traditional aluminum pumps and motors are used at the limit of their performance; eg. for installation on mobile equipment intended for heavy duty operating cycles, where pressures or mechanical stresses are typically higher.

- Long life expectancy.
- High efficiencies.
- High pressure limits.
- Reduced number of components.
- Reduced overall dimension.

The **Titan** Series two-piece construction allows an increase in pressures with P1 up to 300 bar (4350 psi) pressure on a wide displacement range from 23.9 to 79.8 cm³/rev (1.46 to 4.87 in³/rev).

The **Titan** Series completes the cast iron pump range. Thanks to a wide range of integrated valves, this pump is suitable for mobile applications in Agricultural and Construction/Earth Moving sectors (Skid Steer Loaders, Telehandlers and Backhoe Loaders).

The main features are:

- FEMALE SPLINE Compact Tandem Capability
- SAE B, SAE C and EUR front flanges
- HIGHER SHAFT DIAMETER; Ø32 mm (1.26 in), up to 900 Nm (664 lbft) and up to up to 500 Nm (369 lbft) between stages
- NEW SHAFTS SAE S15, 16/32 inch keyed
- REVERSIBLE SEALING
- Special configurations for DEALERS



Additional information

This catalogue shows the product in the most standard configurations. Please, contact Sales Dpt. for more detailed information or special requests.

WARNING!

All specifications of this catalogue refer to the standard product at this date. Walvoil, oriented to a continuous improvement, reserves the right to discontinue, modify or revise the specifications without notice.

WALVOIL IS NOT RESPONSIBLE FOR ANY DAMAGE CAUSED BY AN INCORRECT USE OF THE PRODUCT.

General Informations

Features	4
Technical information	6
Definitions	7
Ports position	8
Operative parameters	9
Working pressure definitions	9
Pressure and rotation speed	10
Flow and rotation speed	11
Torque and Power diagrams	12
Seal rings	15
3TPW/3TMW main dimensional data	16
Ports threading and connections	18

Single units

Description composition	page 20
Flange kits	22
Gear thrust plate kits	23
Driving gear shafts	24
Driven gears	27
Standard bodies	27
Special bodies	29

Tandem pumps

Tandem pumps general informations	page 32
Tandem kits and bodies specifications	33
Second stage dedicated driving gears	34
2XP/2XPW secondary stage	35
3TPW primary and secondary stage	39
Complete pumps ordering codes	page 42
Secondary stage ordering codes	44
Assembling screws ordering codes	45
Product identification	46

Features

Working conditions

This catalogue shows technical specifications and diagrams measured with mineral oil of 46 mm²/s (46 cSt) viscosity at 40°C (104°F) temperature.

Displacement		from 23.9 to 79.8 cm ³ /rev - from 1.46 to 4.87 in ³ /rev
Max continuous pressure	up to	300 bar - 4350 psi
Fluid		hydraulic mineral oil-based
Fluid temperature range	with NBR (buna N) seals	from -20 to +80 °C - from -4 to +176 °F
	with FPM (viton) seals	from -15 to +100 °C - from +5 to +212 °F
Viscosity	Recommended	from 15 to 92 mm ² /s (cSt)
	Permitted for starting	2000 mm ² /s (cSt)
Max level of contamination	Recommended for operating pressure > 150 bar (2150 psi)	20/18/15 ISO 4406 - class 9 (NAS 1638)
	Recommended for operating pressure < 150 bar (2150 psi)	21/19/16 ISO 4406 - class 10 (NAS 1638)

NOTE: for motor configuration please contact our Sales Department

Displacement

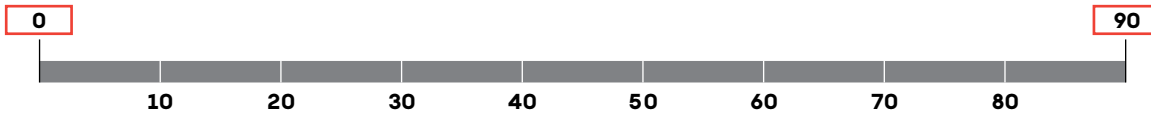

Group 3TPW/3TMW	Displacement	
	cm ³ /rev	in ³ /rev
230	23.9	1.46
280	28.0	1.71
320	32.2	1.96
390	39.7	2.42
430	43.8	2.67
470	47.9	2.92
520	52.0	3.18
560	56.8	3.47
600	60.9	3.72
650	65.0	3.97
710	71.6	4.37
790	79.8	4.87

Flanges range

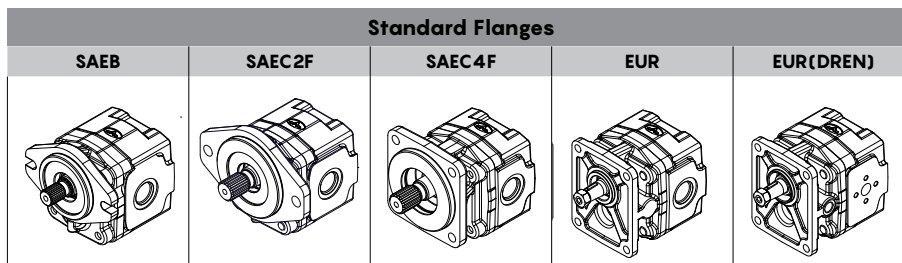

Shaft / flange combination

Shafts			Flanges			
Type	Description	Transmitted torque (max)	SAEB	SAEC2F	SAEC4F	EUR
10	Tapered 1:8	240 Nm - 178 lbft	-	-	-	•
13	SAEB parallel shaft	200 Nm - 148 lbft	•	•	-	-
S13	SAEB 13T splined	280 Nm - 207 lbft	•	•	-	-
S13N	SAEB 13T splined NS (increased torque)	300 Nm - 221 lbft	•	•	-	-
S14	SAEC 14T splined	900 Nm - 664 lbft	•	•	-	-
S14L	SAEC 14T splined L (long)	900 Nm - 664 lbft	-	-	•	-
S15	SAEBB 15T splined	400 Nm - 296 lbft	•	•	-	-
S15L	SAEBB 15T splined L (long)	400 Nm - 296 lbft	-	-	•	-

• = standard configuration - = non-standard configuration
 NOTE: for more informations please see dedicated pages (from 24 to 26)

Technical informations

Hydraulic fluid

It is advisable to use hydraulic oils of mineral origin with anti-foaming, antiwear, anti-oxidant and anti-corrosion characteristics and rapid air removal properties and a high viscosity index;

- Recommended viscosity 15÷92 mm²/s (15÷92 cSt)
- Start-up viscosity limit 2000 mm²/s (2000 cSt)
- Max. operating viscosity 750 mm²/s (700 cSt)

During normal operation, the oil temperature must be between 20°C (68°F) and 65°C (149°F) with limit values between -20°C (-4°F) and 80°C (176°F) with NBR seals and limit values between -15°C (5°F) and 100°C (212°F) with Viton seals.

Suction pressure

The allowed working pressure supplied must be in the range 0.7 - 2 bar (10.2 - 29 psi) [absolute].

For higher values (up to 30 bar / 435 psi), it is necessary to use sealing ring for high pressures.

Particular attention must be given to the sizing of rigid or flexible pipes, avoiding disproportionate lengths, sudden variations in inner diameter or small curvature radius, in any case selecting pipe inner diameter that guarantee an oil speed between 0.6 m/s (1.97 ft/s) and 2 m/s (6.56 ft/s).

Filtration

In order to eliminate any oil impurity and to guarantee a longer duration of the pump, the system must be equipped with effective filtration, whose operation must be periodically checked.

The recommended filtration levels are as follows:

$\Delta p < 150$ bar (2175 psi):

21/19/16 (ISO 4406) - class 10 (NAS 1638)

150 bar (2175 psi) < $\Delta p < 210$ bar (3050 psi):

20/18/15 (ISO 4406) - class 9 (NAS 1638)

$\Delta p > 210$ bar (3050 psi):

19/17/14 (ISO 4406) - class 8 (NAS 1638)

Installation notes

Before starting the system setting, some precautions are recommended:

- Check that the direction of rotation is consistent with the drive shaft one.
- Remove all dirt, chips and all foreign bodies from flanges connecting inlet and delivery ports.
- Protect the drive shaft sealing ring during pump painting; check that the contact area between ring and shaft is clean: dust or abrasive sediments could accelerate the wear and cause leakages.
- Check that there are no misalignments between the pump/motor shaft and the main shaft.
- Radial and/or axial loads on the pump shaft (such as when driving is carried out through pulleys or chains) are not admitted.
- The coupling joint between the spline shafts has to be properly lubricated, free to move axially and of a suitable length to cover both motor and pump shafts.

Notes:

- Do not start the system under load at low temperatures or after long stops.
- Check the whole system filling by bleeding off the whole air amount after few minutes of system working.
- Increase the pressure until you reach the operating values by keeping checked the fluid and the moving parts temperature and the rotation speed. Maintain the set values within the limits specified in this catalogue.

Pump wise rotation

The rotation wise is defined as **S** (counter-clockwise) or **D** (clockwise) by observing the shaft from the front. In case of counter-clockwise rotation **S** the suction will be to the right of the drive shaft while the delivery will be to your left; the opposite will be for monodirectional pump right **D**. When ordering, it is necessary to specify the required rotation; direction or it is possible to modify the internal structure as illustrated on the next page (reversal). **X** defines reversible pump rotation with internal drain.

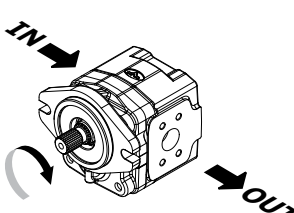
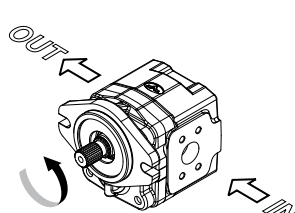
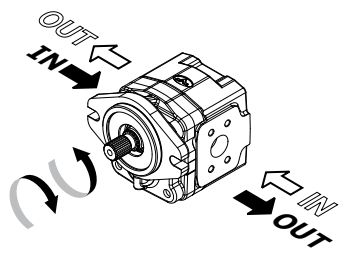
D	Clockwise rotation	S	Counter-clockwise rotation	X	Reversible rotation
	<p>Suction - low pressure</p>  <p>Delivery - high pressure</p>	<p>Delivery - high pressure</p>  <p>Suction - low pressure</p>			

Motor wise rotation

The rotation wise is defined by observing the shaft frontally: **S** (counter-clockwise) and **D** (clockwise). In case of **S** counter-clockwise rotation, outlet port will be the left of the shaft while inlet port to its right; the opposite layout is used in case of **D** clockwise rotation. When ordering please specify the required rotation wise of monodirectional motors, otherwise modify the internal assembly layout as indicated on the next page (otation reversal). **R** defines reversible motor rotation with external drain. **X** defines reversible pump rotation with internal drain.

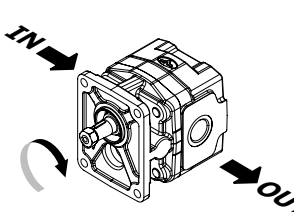
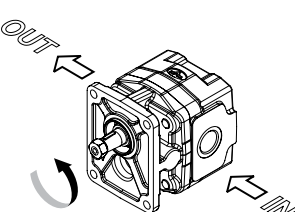
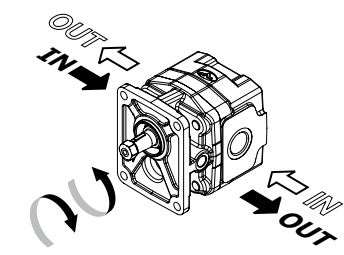
D	Clockwise rotation	S	Counter-clockwise rotation	R	X	Reversible rotation
	<p>Inlet - high pressure</p>  <p>Outlet - low pressure</p>	<p>Outlet - low pressure</p>  <p>Inlet - high pressure</p>				

Definitions

Pump/motor rotation reversal

How to invert the wise rotation:

- Disassemble the pump by unscrewing the screws **A** (allen wrench 12) and remove the flange **B**.
- Pull off the driving gear **C** with the upper thrust plate kit **D**; the lower thrust plate kit must remain in place.
- Remove the driven gear **E** and insert it into the driving gear seat, insert the driving gear **C** in the other seat.
- Insert the upper thrust plate kit **D** in the previous position.
- Unscrew the plug **F** on the flange **B** and screw it into the other threaded hole, then assemble the flange by rotating it 180°.
- Reassemble the pump by tightening the screws **A** with a torque of 160 Nm (118 lbf^t).

NOTE: the rotation reversal procedure is not applicable to reversible motors.

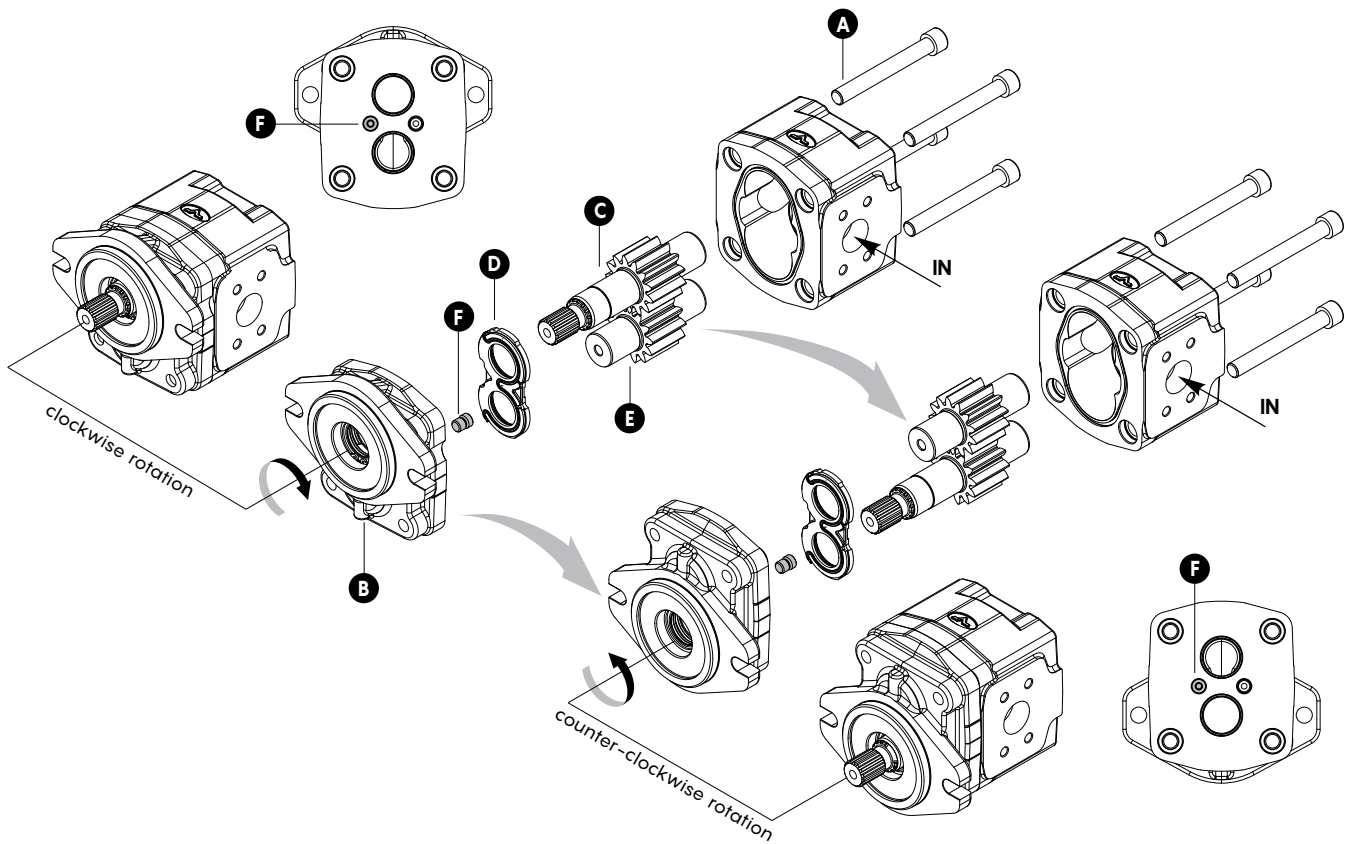

Ports position

Available connection positions			
0	1	3	4

Clockwise rotation - **D**
 Counter-clockwise rotation - **S**

Operative parameters

Hydraulic measures			Conversion factor	
Q	Flow	(l/min - USgpm)	1 l/min	0.2641 USgpm
M	Torque	(Nm - lbf ^t)	1 Nm	8.851 lbf ^t
P	Power	(kW - HP)	1 Nm	0.7375 lbf ^t
V	Displacement	(cm ³ /rev - in ³ /rev)	1 N	0.2248 lbf
n	Speed	(rpm - min ⁻¹)	1 kW	1.34 HP
Δp	Pressure	(bar - psi)	1 cm ³ /rev	0.061 in ³ /rev
η_v	Volumetric efficiency		1 bar	14.5 psi
η_m	Mechanical efficiency		1 mm	0.0394 in
η_t	Overall efficiency		1 kg	2.205 lbs

Working pressure definition

The pumps can be subjected to the P1, P2 or P3 pressures shown in the performance tables. The following diagram illustrates the definitions and applicability by respecting the included rotation speed limits.

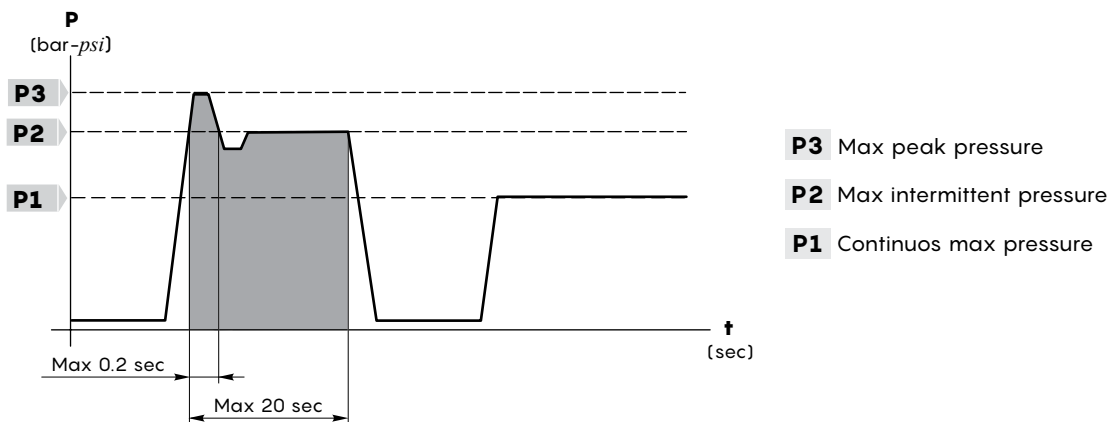

Pressure and rotation speed

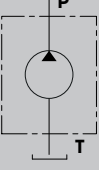
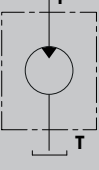
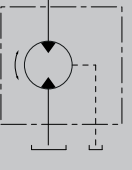
Symbol	Type	Displacement		P1 Max continuous pressure		P2 Max intermittent pressure		P3 Max peak pressure		Rotation speed		
		cm ³ /rev	in ³ /rev	bar	psi	bar	psi	bar	psi	max rpm	min rpm	
Unidirectional pump/motor type												
	3TPW/3TMW 230	23.9	1.46	300	4350	320	4650	330	4780	3000	500	
	3TPW/3TMW 280	28.0	1.71	300	4350	320	4650	330	4780	3000	500	
	3TPW/3TMW 320	32.2	1.96	300	4350	320	4650	330	4780	3000	500	
	3TPW/3TMW 390	39.7	2.42	300	4350	320	4650	330	4780	3000	500	
	3TPW/3TMW 430	43.8	2.67	300	4350	320	4650	330	4780	3000	500	
	3TPW/3TMW 470	47.9	2.92	290	4200	310	4490	320	4650	3000	500	
	3TPW/3TMW 520	52.0	3.18	290	4200	310	4490	320	4650	2800	500	
	3TPW/3TMW 560	56.8	3.47	290	4200	310	4490	320	4650	2500	500	
	3TPW/3TMW 600	60.9	3.72	270	3910	290	4200	300	4350	2500	500	
	3TPW/3TMW 650	65.0	3.97	250	3620	270	3910	280	4050	2500	500	
	3TPW/3TMW 710	71.6	4.37	230	3330	250	3620	260	3770	2500	500	
	3TPW/3TMW 790	79.8	4.87	210	3050	230	3330	240	3480	2500	500	
	Reversible motor type											
		3TMW 230	23.9	1.46	300	4350	320	4650				
3TMW 280		28.0	1.71	300	4350	320	4650					
3TMW 320		32.2	1.96	300	4350	320	4650					
3TMW 390		39.7	2.42	300	4350	320	4650					
3TMW 430		43.8	2.67	300	4350	320	4650					
3TMW 470		47.9	2.92	290	4200	310	4490					
3TMW 520		52.0	3.18	290	4200	310	4490					
3TMW 560		56.8	3.47	290	4200	310	4490					
3TMW 600		60.9	3.72	270	3910	290	4200					
3TMW 650		65.0	3.97	250	3620	270	3910					
3TMW 710		71.6	4.37	230	3330	250	3620					
3TMW 790		79.8	4.87	210	3050	230	3330					

Flow and rotation speed

3TPW Pumps

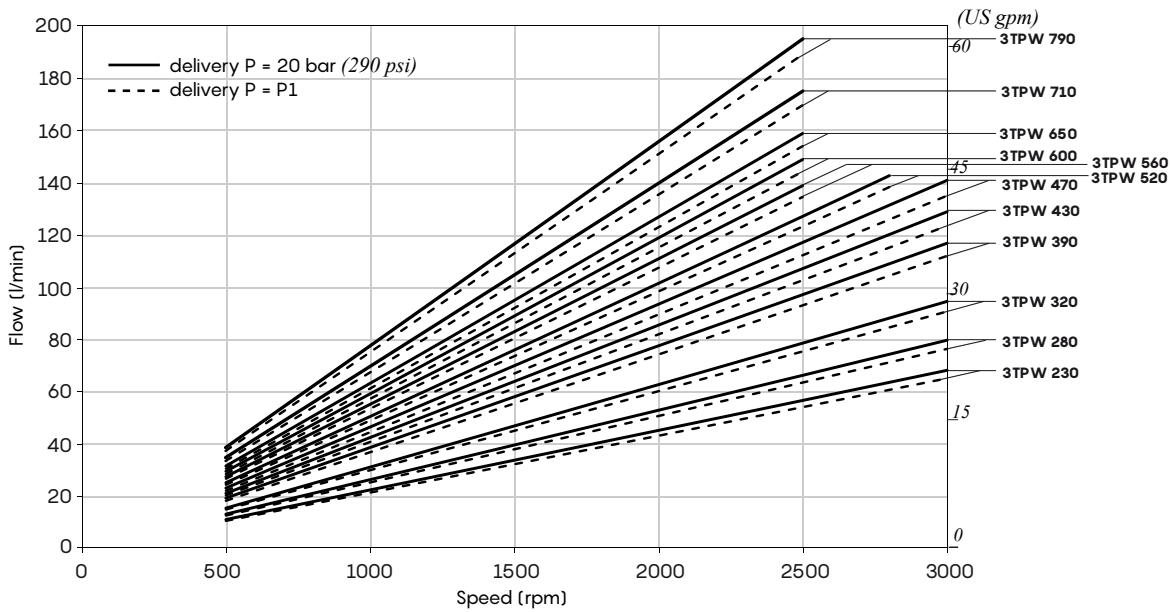

Reference values*
 $\eta_v \approx 0.97$
 $\eta_m \approx 0.88$
 $\eta_t = \eta_v \cdot \eta_m \approx 0.85$

3TMW Motors

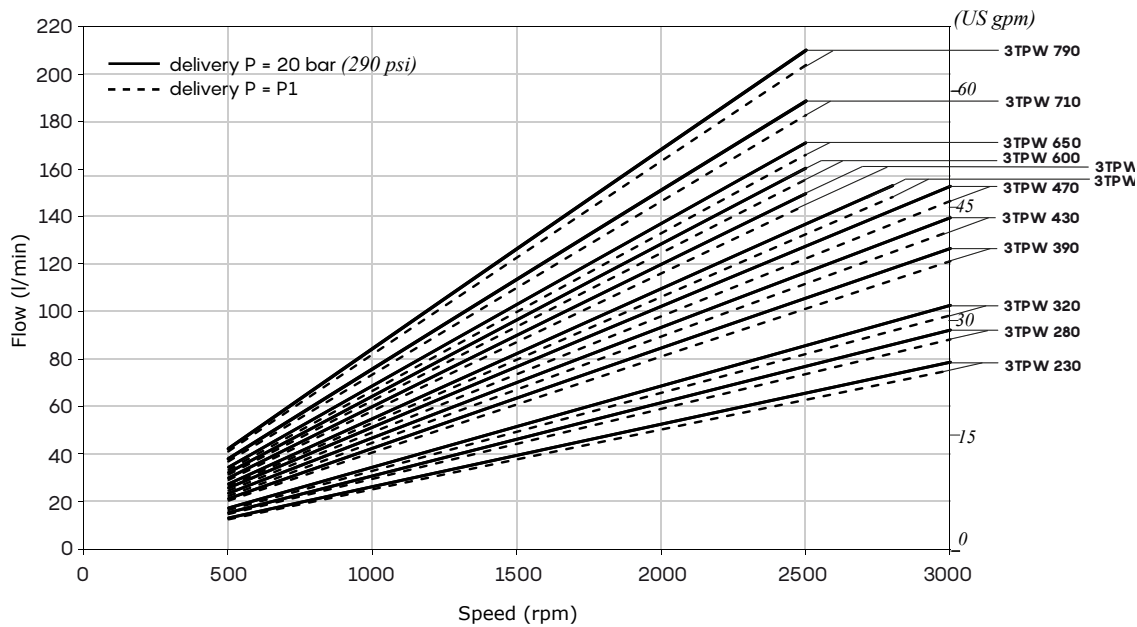

Reference values*
 $\eta_v \approx 0.96$
 $\eta_m \approx 0.85$
 $\eta_t = \eta_v \cdot \eta_m \approx 0.82$

Hydraulic measures		
Q =	$V \cdot \eta_v \cdot n / 1000$	(l/min)
	$V \cdot \eta_v \cdot n / 231$	(USgpm)
M =	$\Delta p \cdot V$	(Nm)
	$62.83 \cdot \eta_m$	
	$\Delta p \cdot V$	(lfb.in)
	$2 \cdot 3.14 \cdot \eta_m$	

Hydraulic measures		
P =	$\Delta p \cdot V \cdot n$	(kW)
	$600 \cdot 1000 \cdot \eta_t$	
	$\Delta p \cdot V \cdot n$	(HP)
	$395934 \cdot \eta_t$	

NOTE: (*)@1500 rpm with ISO VG46 Oil @40°C (104 °F)

Torque and Power diagrams

3TPW pumps

3TPW 230

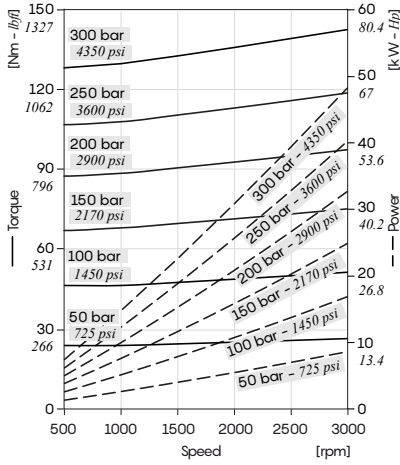

3TPW 280

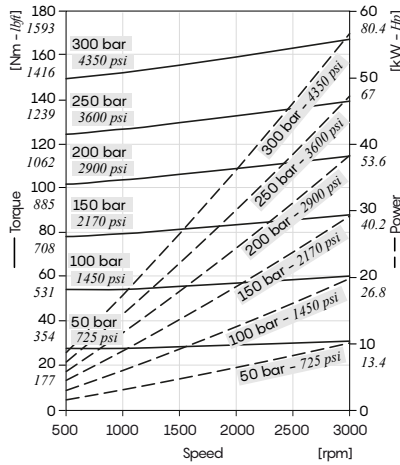

3TPW 320

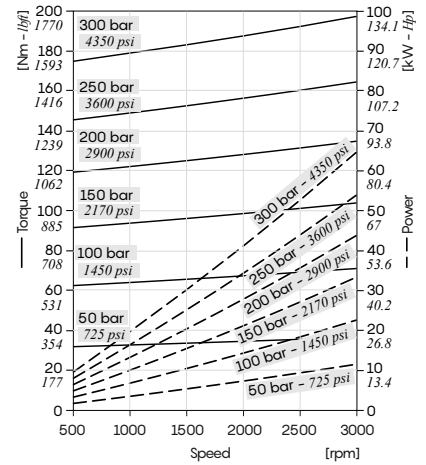

3TPW 390

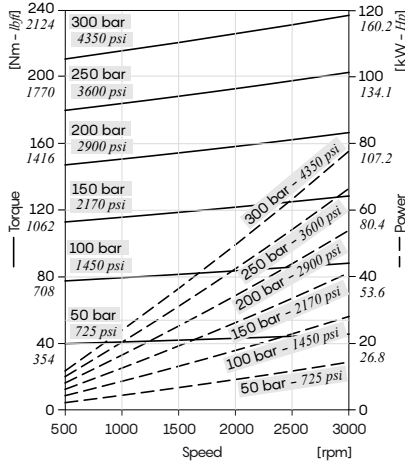

3TPW 430

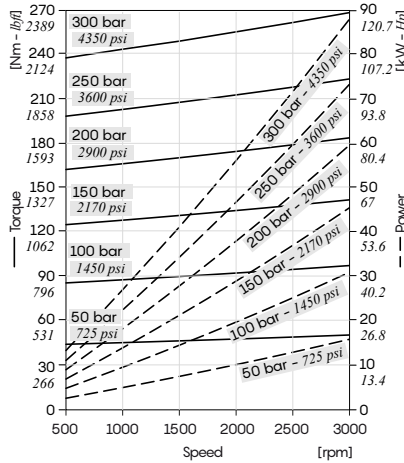

3TPW 470

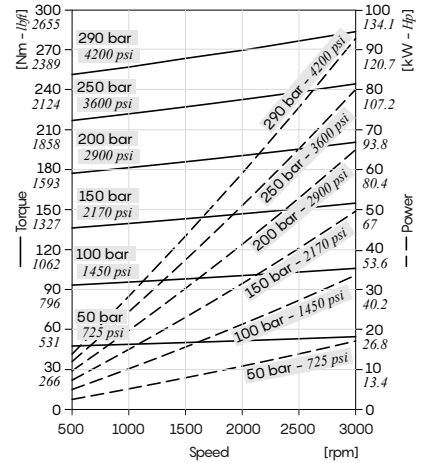

3TPW 520

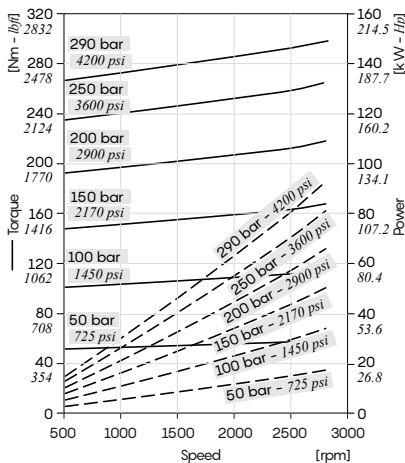

3TPW 560

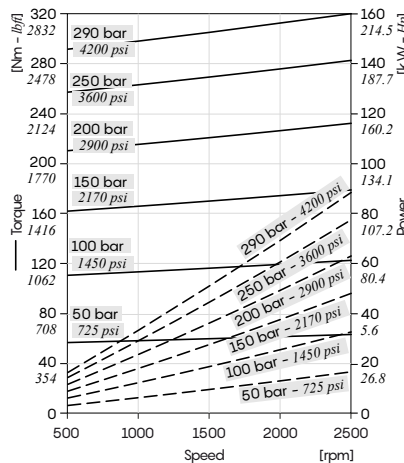

3TPW 600

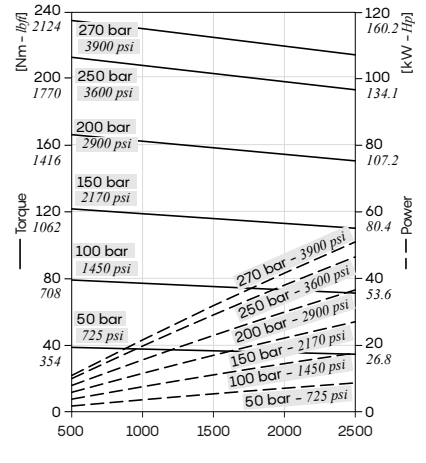

3TPW pumps

3TPW 650

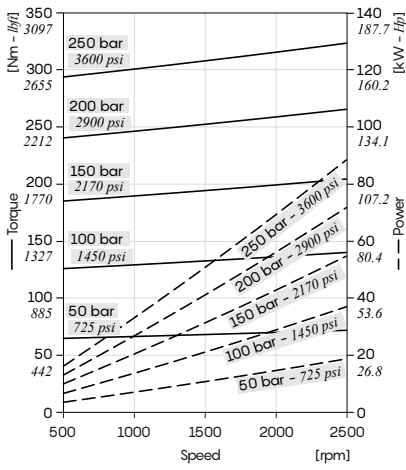

3TPW 710

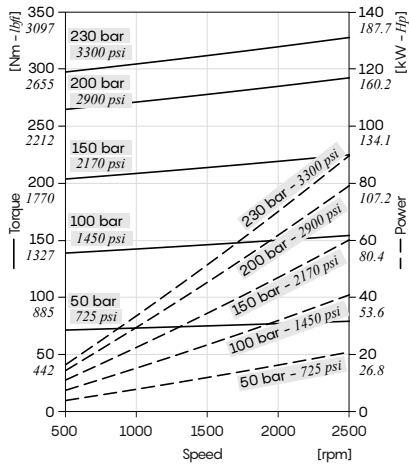

3TPW 790

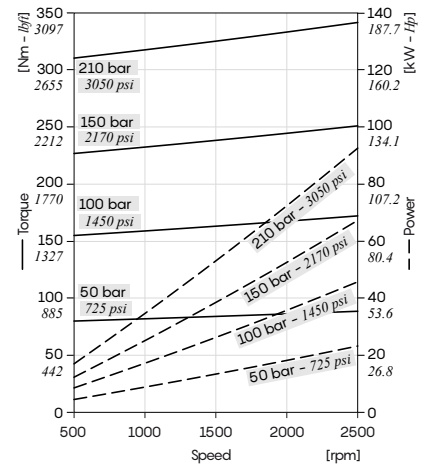

3TMW motors

3TMW 230

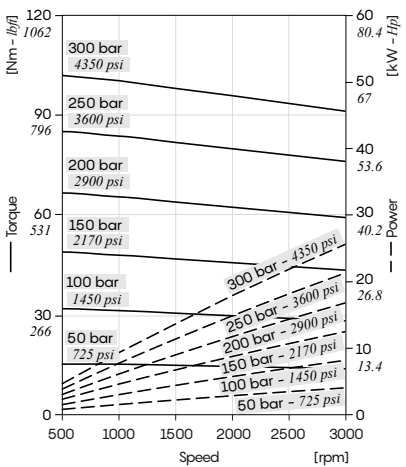

3TMW 280

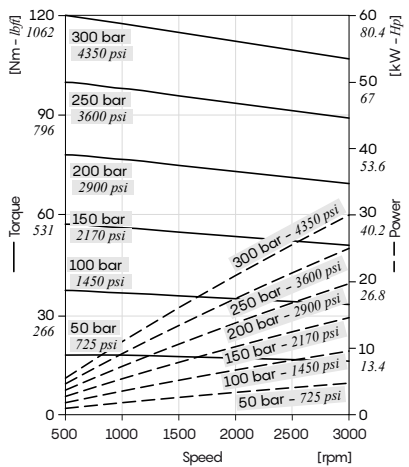

3TMW 320

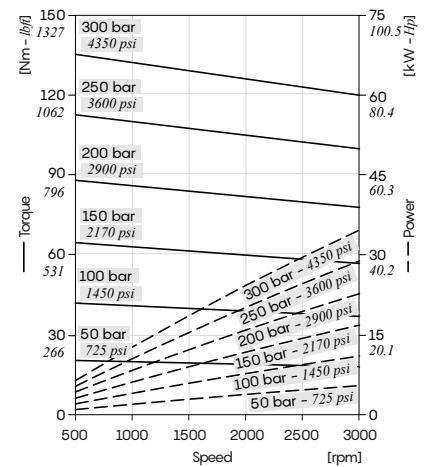

Torque and Power diagrams

3TMW motors

3TMW 390

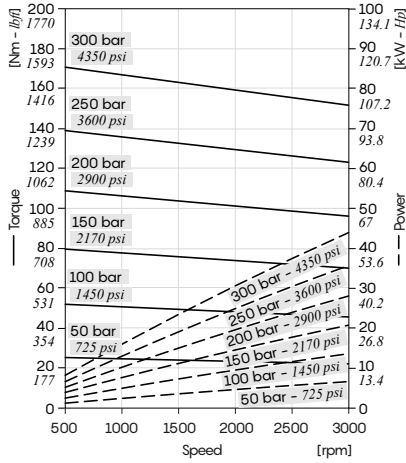

3TMW 430

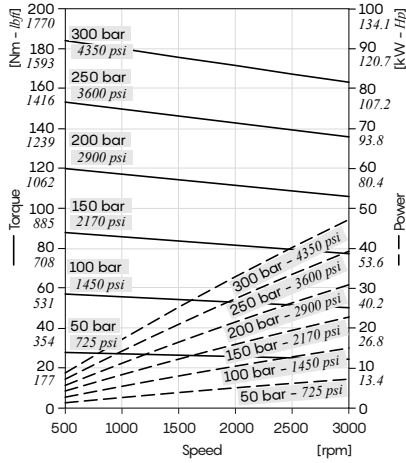

3TMW 470

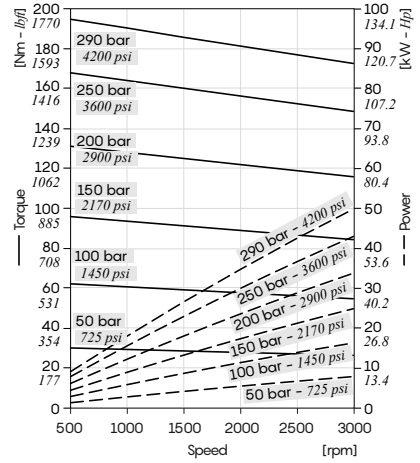

3TMW 520

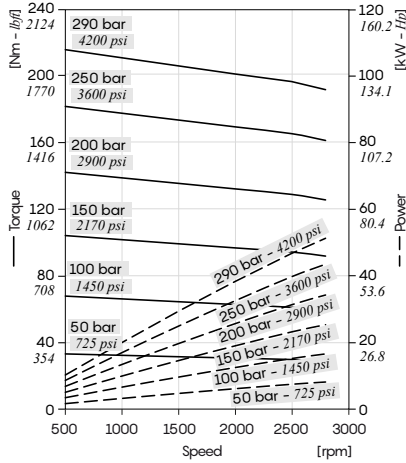

3TMW 560

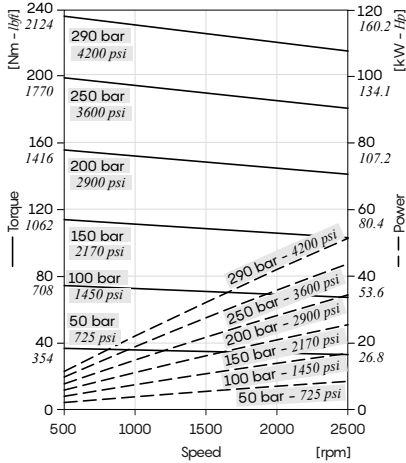

3TMW 600

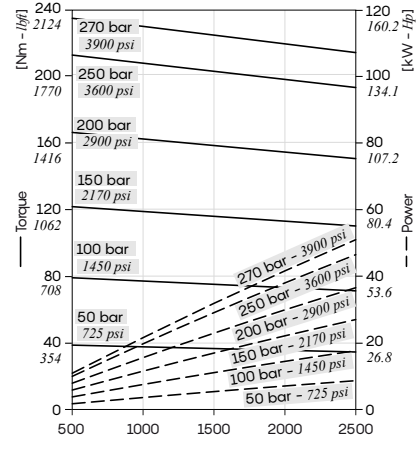

3TMW 650

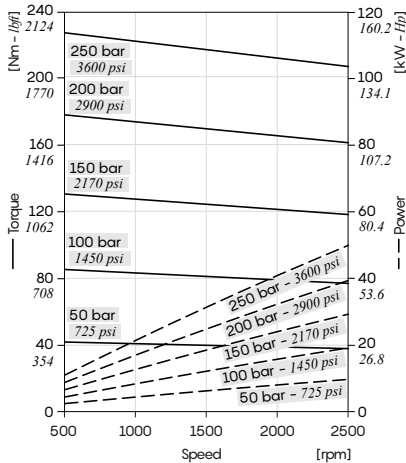

3TMW 710

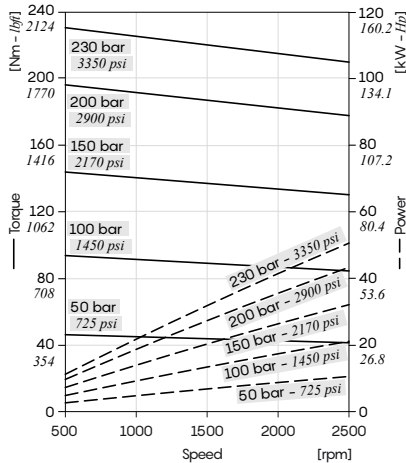

3TMW 790

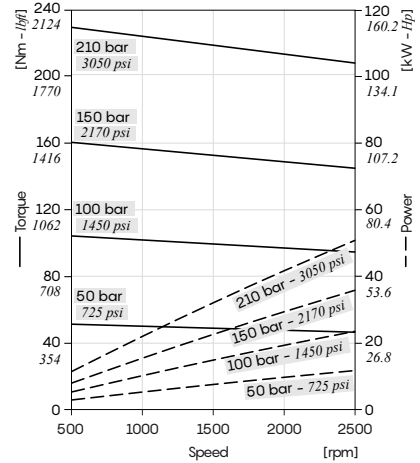

Shaft sealing (main sealing)

Shaft seal configuration	Pressure code	
	B Pumps	K Motors
Without shaft seal	-	-
Standard: with shaft seal Type 2: with double shaft seal (or shaft seal+dust seal)	Max pressure up to 3 bar (43.5 psi) @ 500 rpm 0.7 bar (10.1 psi) @ 3000 rpm	Max pressure up to 30 bar (435 psi) @ 500 rpm 8 bar (116 psi) @ 3000 rpm

"-" = not available

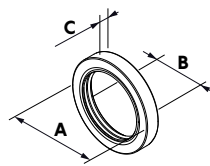

Shaft seals dimensions		
	mm	in
ØA	45	1.77
ØB	32	1.26
C	7	0.276

With shaft seal: standard flange kit
Flange example: EUR
3TPW-G0-230-D-EUR-B-N-10-0-G1G34

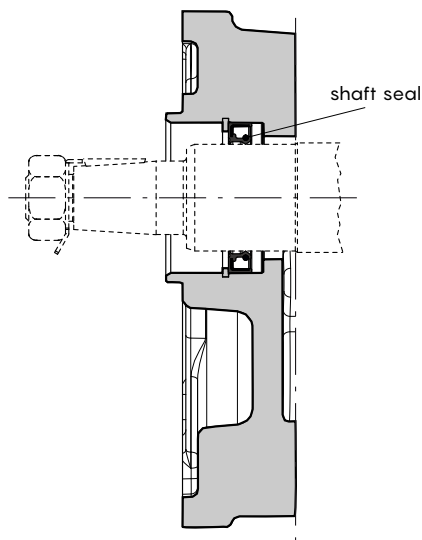

With double shaft seal (or shaft seals+ dust seals)
Flange example: EUR
3TPW-G0-230-D-EUR2-BB-N-10-0-G1G34

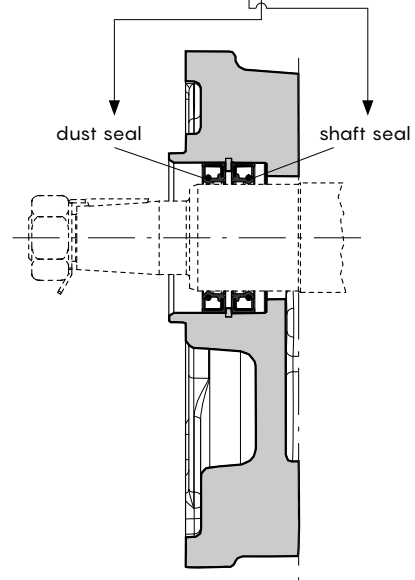

NOTES

NBR and FPM sealing types are available; for other materials and further information please contact our Sales Dpt.
High pressure shaft seal are available on request; please contact our Sales Dpt.

3TPW/3TMW main dimensional data

Pump description example

3TPW-G0-650-D-SAEB-B-N-S13-O-G114G1

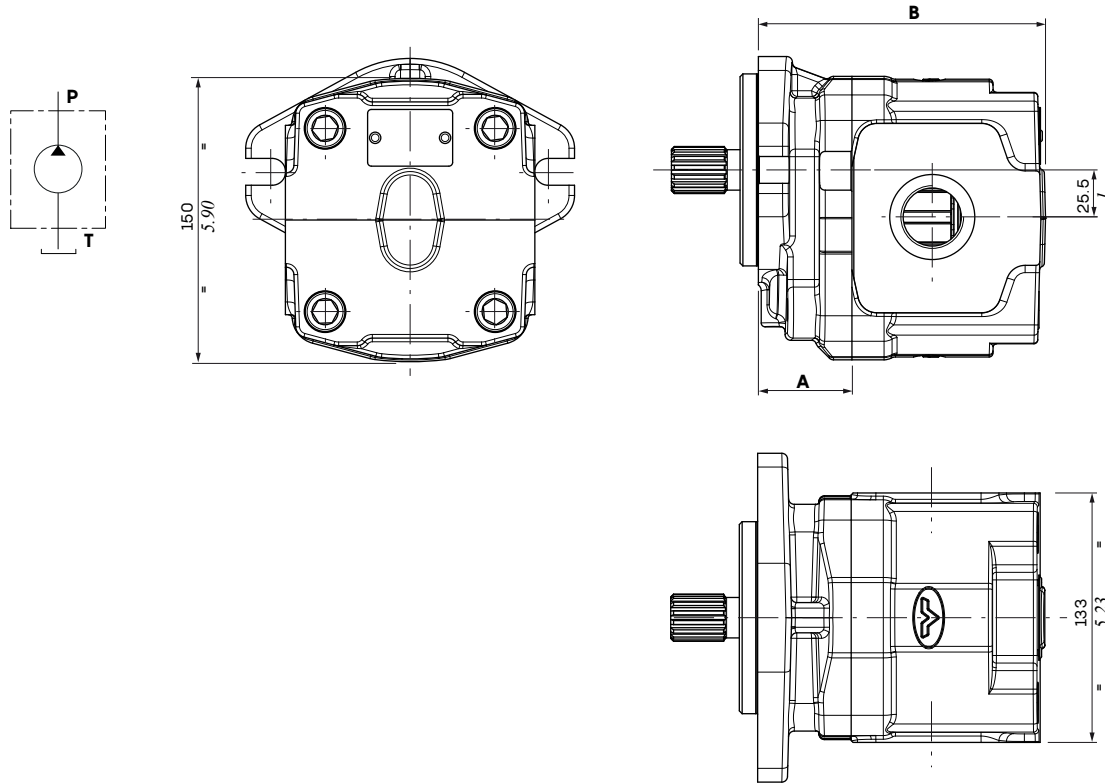

Flange type								
Dimension A								
EUR		SAEB		SAEC2F		SAEC4F		
mm	in	mm	in	mm	in	mm	in	
66	1.33	49.5	1.95	49.5	1.95	82	3.23	
Displacement	Dimension B							
	EUR		SAEB		SAEC2F		SAEC4F	
	mm	in	mm	in	mm	in	mm	in
230	144.5	5.69	128	5.04	128	5.04	160.5	6.32
280	147.5	5.81	131	5.16	131	5.16	163.5	6.44
320	150.5	5.93	134	5.28	134	5.28	166.5	6.56
390	156	6.14	139.5	5.49	139.5	5.49	172	6.77
430	159	6.26	142.5	5.61	142.5	5.61	175	6.89
470	162	6.38	145.5	5.73	145.5	5.73	178	7.01
520	165	6.50	148.5	5.85	148.5	5.85	181	7.13
560	168.5	6.63	152	5.98	152	5.98	184.5	7.26
600	171.5	6.75	155	6.10	155	6.10	187.5	7.38
650	174.5	6.87	158	6.22	158	6.22	190.5	7.5
710	179.5	7.07	163	6.42	163	6.42	195.5	7.70
790	185.5	7.30	169	6.65	169	6.65	201.5	7.93

NOTE: for flanges dimensions see pages 22/23.

3TPW/3TMW main dimensional data

Motor description example

3TMW-G0-430-R-EUR(DREND)-K-N-10-0-N27N27-DRENG38

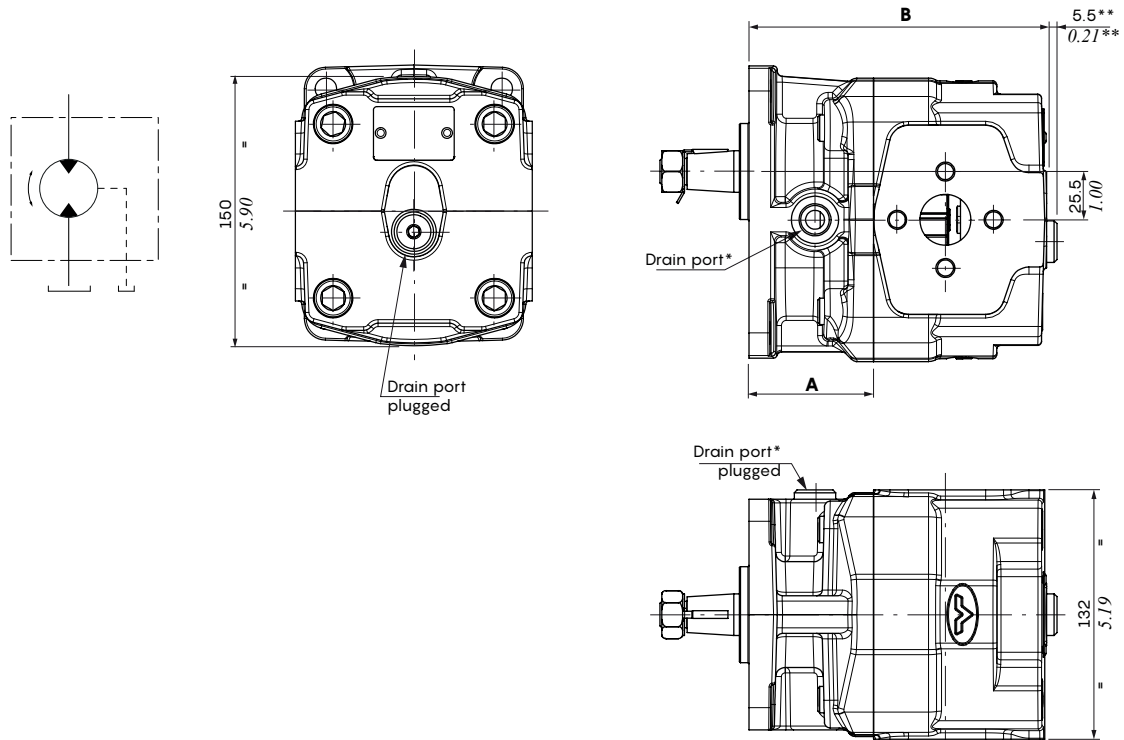

(*): only for EUR flange
(**): referred to BSP thread

		Flange type									
		Dimension A									
		EUR		SAEB		SAEC2F		SAEC4F			
mm		in		mm		in		mm		in	
		66	1.33	49.5	1.95	49.5	1.95	82	3.23		
Displacement	Dimension B										
	EUR		SAEB		SAEC2F		SAEC4F				
mm		in		mm		in		mm		in	
230	143	5.63	126.5	4.98	126.5	4.98	159	6.26			
280	146	5.75	129.5	5.10	129.5	5.10	162	6.38			
320	149	5.87	132.5	5.22	132.5	5.22	165	6.50			
390	154.5	6.08	138	5.43	138	5.43	170.5	6.72			
430	157.5	6.20	141	5.55	141	5.55	173.5	6.83			
470	160.5	6.32	144	5.67	144	5.67	176.5	6.95			
520	163.5	6.44	147	5.79	147	5.79	179.5	7.07			
560	167	6.57	150.5	5.93	150.5	5.93	183	7.20			
600	170	6.69	153.5	6.04	153.5	6.04	186	7.32			
650	173	6.81	156.5	6.16	156.5	6.16	189	7.44			
710	178	7.01	161.5	6.36	161.5	6.36	194	7.64			
790	184	7.24	167.5	6.59	167.5	6.59	200	7.87			

NOTE: for flanges dimensions see pages 22/23.

Ports threading and connections

G (BSP) port threading

Displ.	Side ports - Rear drain				
	Pumps and unidir. motors		Reversible motors		
	LP**	HP**	LP**	HP**	DRAIN
230	G1	G34	G34	G34	G38
280	G1	G34	G34	G34	G38
320	G114	G1	G1	G1	G38
390	G114	G1	G1	G1	G38
430	G114	G1	G1	G1	G38
470	G114	G1	G1	G1	G38
520	G114	G1	G1	G1	G38
560	G114	G1	G1	G1	G38
600	G114	G1	G1	G1	G38
650	G114	G1	G1	G1	G38
710	G112	G1	G1	G1	G38
790	G112	G1	G1	G1	G38

(**) LP = Low presure / HP = High Pressure

	Thread dimension												
	A *	B		C (Ø)		D		LP**		HP**		DRAIN	
		mm	in	mm	in	mm	in	Nm	lbft	Nm	lbft	Nm	lbft
G38	G 3/8"	12	0.47	25	0.98	0.5	0.020	-	-	-	-	15	11
G34	G 3/4"	18	0.71	36	1.48	0.5	0.020	30	22	90	66.4	-	-
G1	G 1"	20	0.79	45	1.77	0.5	0.020	50	37	130	96	-	-
G114	G 1"1/4	20	0.79	60	2.36	0.5	0.020	60	44	170	125	-	-
G112	G1"1/2	22	0.87	60	2.36	0.5	0.020	70	51.5	210	155	-	-

(*) threading according to ISO 228/1 - (**) LP = Low presure / HP = High Pressure

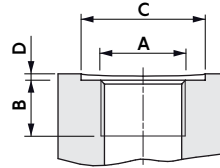

U (UN-UNF) port threading

Displ.	Side ports - Rear drain				
	Pumps and unidir. motors		Reversible motors		
	LP**	HP**	LP**	HP**	DRAIN
230	U16	U12	U12	U12	U06
280	U16	U12	U12	U12	U06
320	U20	U16	U16	U16	U06
390	U20	U16	U16	U16	U06
430	U20	U16	U16	U16	U06
470	U20	U16	U16	U16	U06
520	U20	U16	U16	U16	U06
560	U20	U16	U16	U16	U06
600	U20	U16	U16	U16	U06
650	U20	U16	U16	U16	U06
710	U20	U16	U16	U16	U06
790	U20	U16	U16	U16	U06

(**) LP = Low presure / HP = High Pressure

	Thread dimension												
	A *	B		C (Ø)		D		LP**		HP**		DRAIN	
		mm	in	mm	in	mm	in	Nm	lbft	Nm	lbft	Nm	lbft
U06	9/16-18 (SAE6)	13	0.51	23	0.91	0.5	0.020	-	-	-	-	15	11
U12	1 1/16-12 (SAE12)	20	0.79	41	1.61	0.5	0.020	40	30	120	88	-	-
U16	1 5/16-12 (SAE16)	20	0.79	49	1.97	0.5	0.020	60	44	170	125	-	-
U20	1 5/8-12 (SAE20)	20	0.79	58	2.28	0.5	0.020	70	51.5	200	147	-	-

(*) threading according to ISO 262 - ANSI B1.1 - (**) LP = Low presure / HP = High Pressure

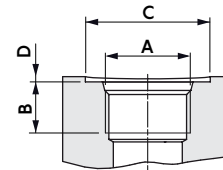

T (GERMAN flange) port connection

Displ.	Side ports - Rear drain				
	Pumps and unidir. motors		Reversible motors		
	LP**	HP**	LP**	HP**	DRAIN
230	T27	T19	T19	T19	G38
280	T27	T19	T19	T19	G38
320	T27	T19	T19	T19	G38
390	T27	T19	T19	T19	G38
430	T27	T19	T27	T27	G38
470	T27	T19	T27	T27	G38
520	T27	T19	T27	T27	G38
560	T27	T19	T27	T27	G38
600	T27	T19	T27	T27	G38
650	T27	T19	T27	T27	G38
710	T27	T19	T27	T27	G38
790	T27	T19	T27	T27	G38

(**) LP = Low presure / HP = High Pressure

	Thread dimension										
	A (Ø)		B (Ø)		C	D		LP**		HP**	
	mm	in	mm	in		mm	in	Nm	lbft	Nm	lbft
T19	19	0.75	55	2.17	M8	17	0.67	20	15	20	15
T27	27	1.06	55	2.17	M8	17	0.67	20	15	20	15

(**) LP = Low presure / HP = High Pressure

NOTE: for drain connection tightening torque see G port threading tables.

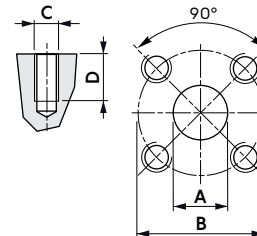

Ports threading and connections

N (EUROPEAN flange) port connection

Displ.	Side ports - Rear drain				
	Pumps and unidir. motors		Reversible motors		
	LP**	HP**	LP**	HP**	DRAIN
230	N27	N19	N19	N19	G38
280	N27	N19	N19	N19	G38
320	N27	N19	N19	N19	G38
390	N27	N19	N19	N19	G38
430	N27	N19	N27	N27	G38
470	N27	N19	N27	N27	G38
520	N27	N19	N27	N27	G38
560	N27	N19	N27	N27	G38
600	N27	N19	N27	N27	G38
650	N27	N19	N27	N27	G38
710	N27	N19	N27	N27	G38
790	N27	N19	N27	N27	G38

	Thread dimension										
	A (Ø)		B (Ø)		C	D		LP**		HP**	
	mm	in	mm	in		mm	in	Nm	lbf ^t	Nm	lbf ^t
N13	13	0.51	30	1.18	M6	15	0.59	9.8	7.2	9.8	7.2
N19	19	0.75	40	1.57	M8	15	0.59	20	15	20	15

NOTE: for drain connection tightening torque see G port threading tables.(**) LP = Low pressure / HP = High Pressure

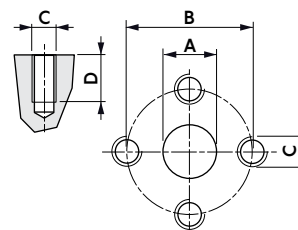

(**) LP = Low pressure / HP = High Pressure

F port connection: dimensions according to SAE J518-1 / ISO 6162-1

Port connection FU with UN-UNF screws and SAE drain port are available on request

Displ.	Side ports - Rear drain				
	Pumps and unidir. motors		Reversible motors		
	LP**	HP**	LP**	HP**	DRAIN
230	F25	F19	F19	F19	U6
280	F25	F19	F19	F19	U6
320	F32	F19	F19	F19	U6
390	F32	F19	F19	F19	U6
430	F32	F25	F25	F25	U6
470	F39	F25	F25	F25	U6
520	F39	F25	F25	F25	U6
560	F39	F32	F32	F32	U6
600	F39	F32	F32	F32	U6
650	F39	F32	F32	F32	U6
710	F39	F32	F32	F32	U6
790	F39	F32	F32	F32	U6

	Thread dimension													
	A (Ø)		B		C		D		E		LP**		HP**	
	mm	in	mm	in	mm	in	mm	in	mm	in	Nm	lbf ^t	Nm	lbf ^t
F19	19	0.78	22.3	0.88	47.6	1.87	M10	18	0.71	30	22	30	22	
F25	25	0.98	26.2	1.03	52.4	2.06	M10	18	0.71	30	22	30	22	
F32	32	1.26	30.2	1.19	58.7	2.31	M10	18	0.71	30	22	30	22	
F39	39	1.54	35.7	1.41	69.9	2.75	M12	23	0.91	42	31	42	31	

NOTES: for drain connection tightening torque see U port threading tables. (**) LP = Low pressure / HP = High Pressure

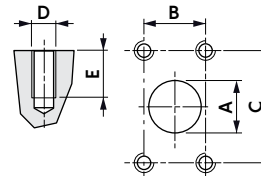

(**) LP = Low pressure / HP = High Pressure

B port arrangement: only pre-drilling

This option is available only for pumps with GOD body configuration; see page 31.

Displacement	Side ports	
	Pumps and unidir. motors	
	LP**	HP**
230	B13	B19
280	B13	B19
320	B19	B27
390	B19	B27
430	B19	B27
470	B19	B27
520	B19	B27
560	B19	B27
600	B19	B27
650	B19	B33
710	B27	B33
790	B27	B33

	Bore dimension	
	A (Ø)	
	mm	in
B13	13	0.51
B19	19	0.75
B27	27	1.06
B33	33	1.30

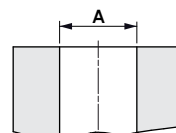

(**) LP = Low pressure / HP = High Pressure

Description composition

3TPW pump configuration example

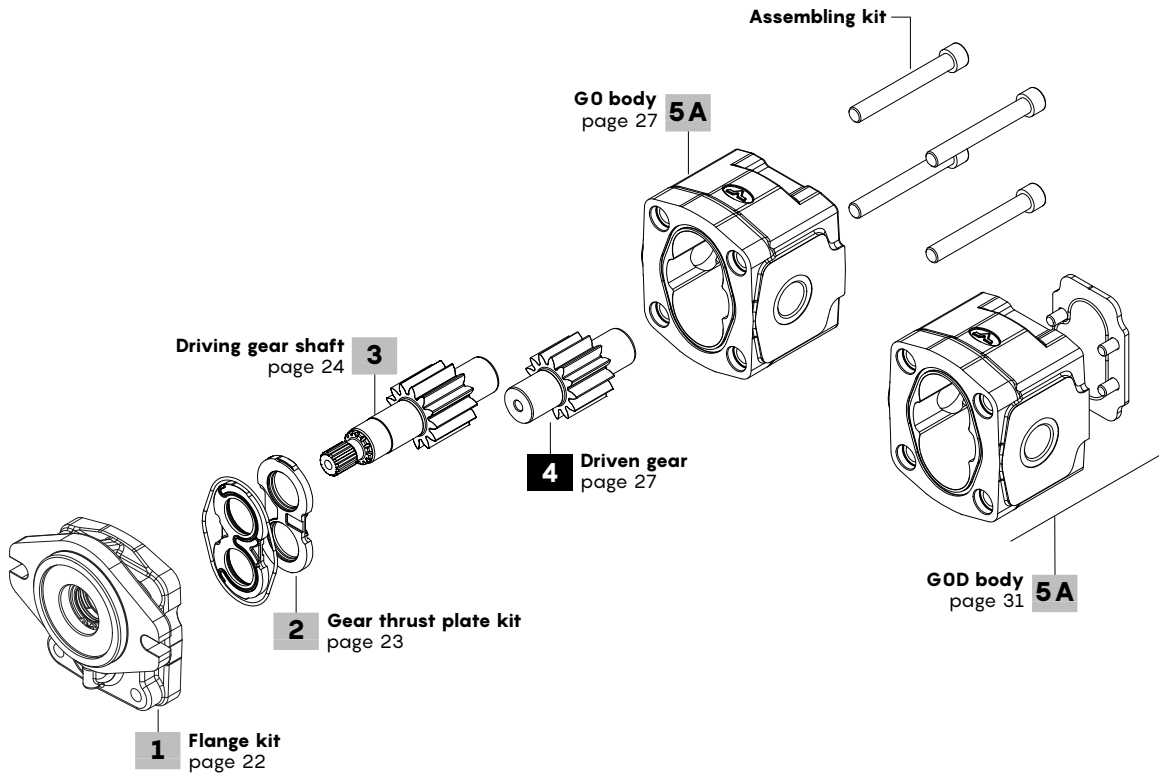
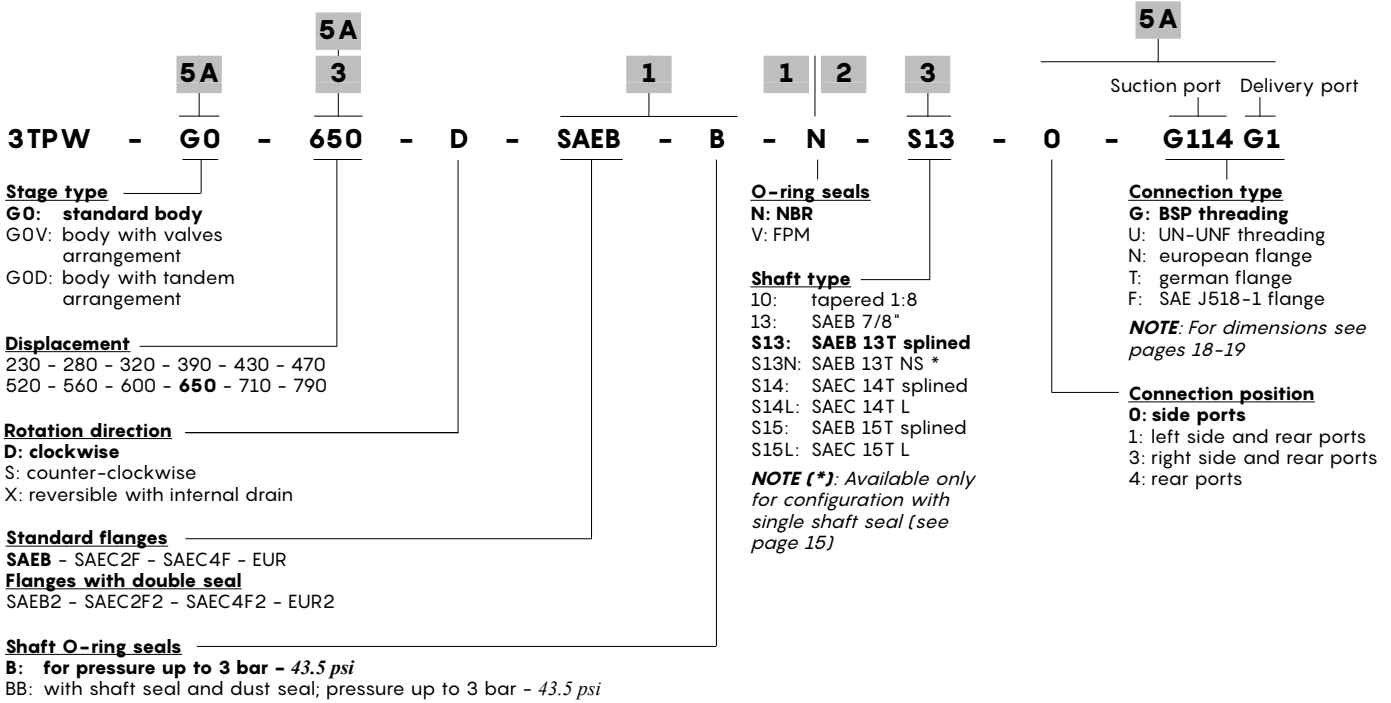

3TMW motor configuration example

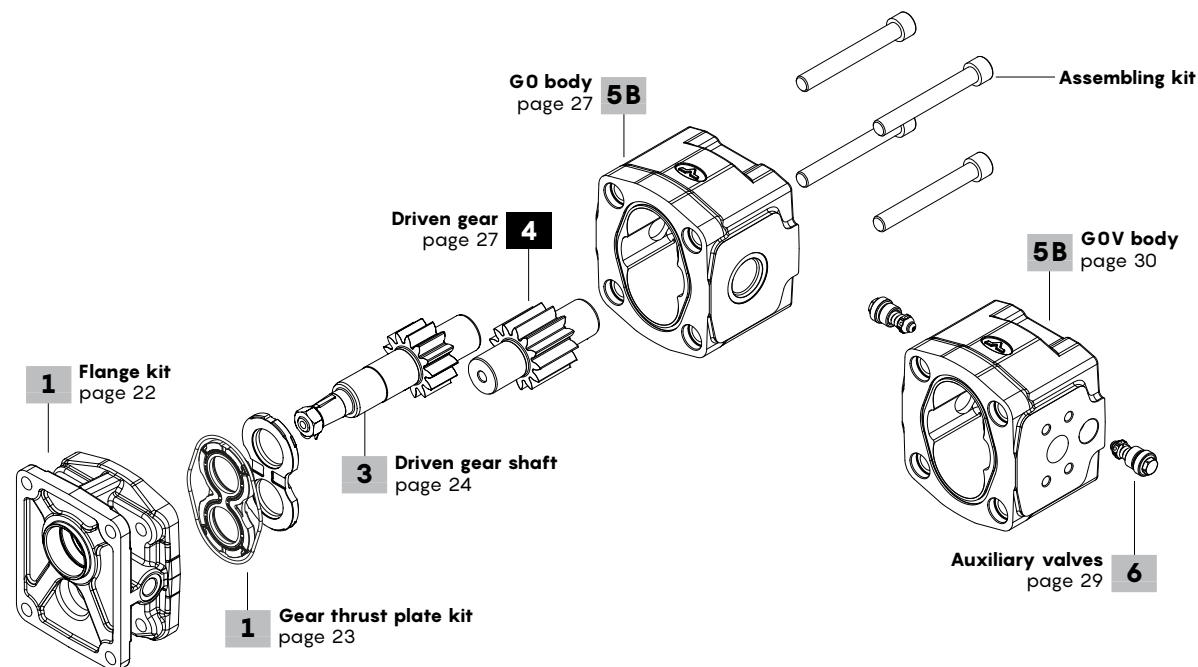
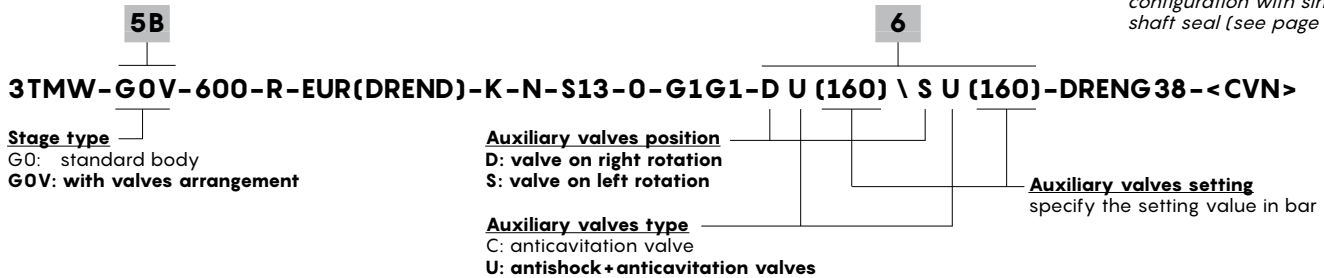
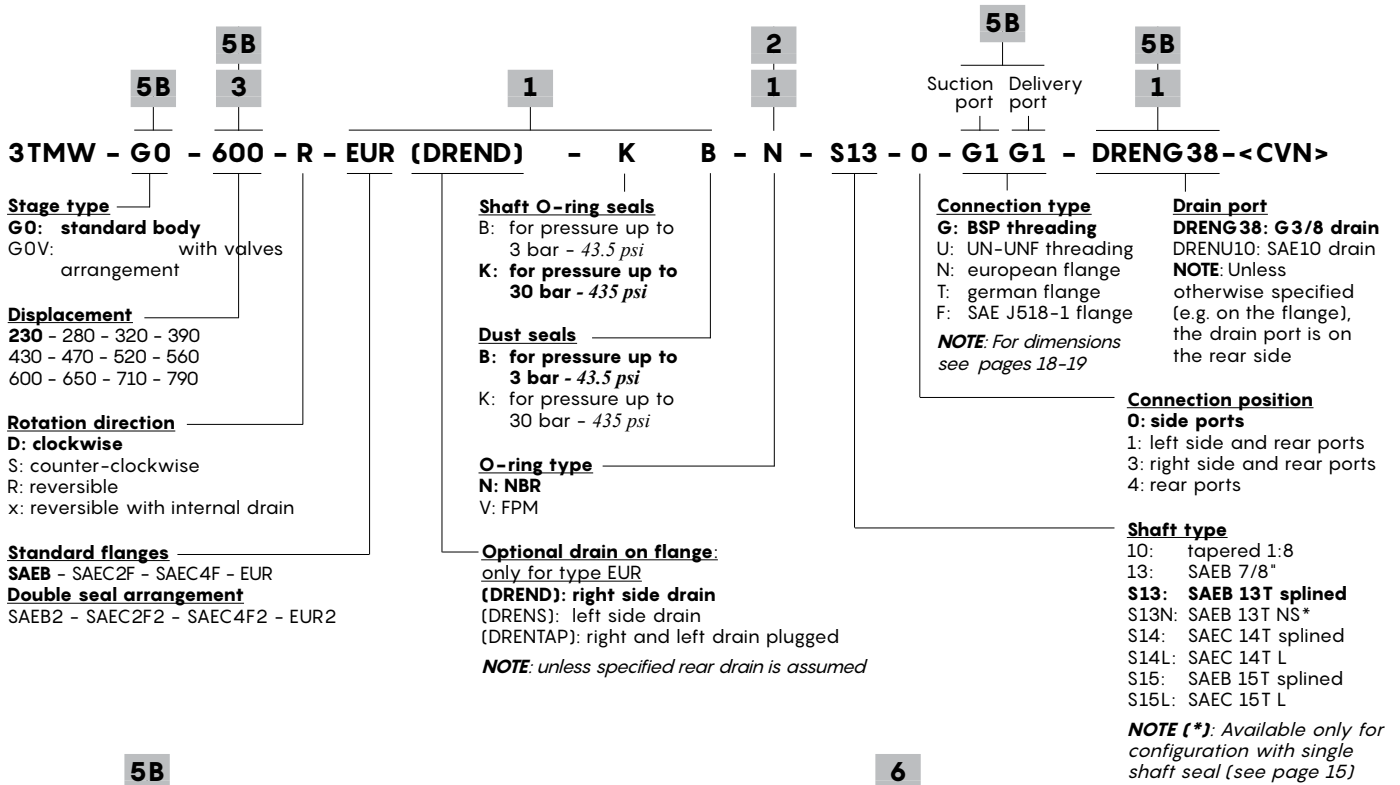

Flanges kits

SAEB type dimensions

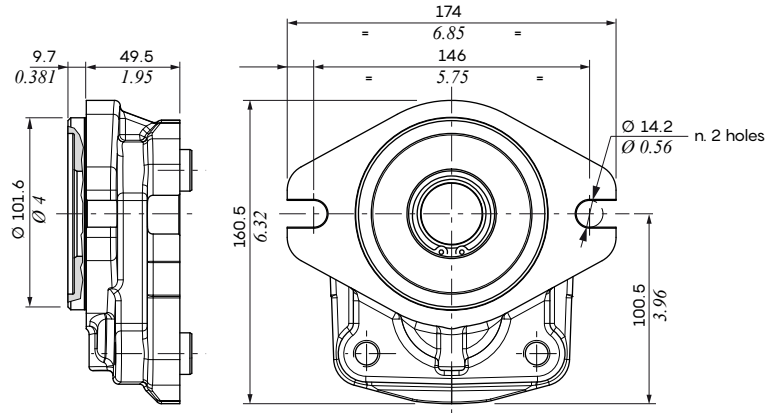

SAEC2F type dimensions

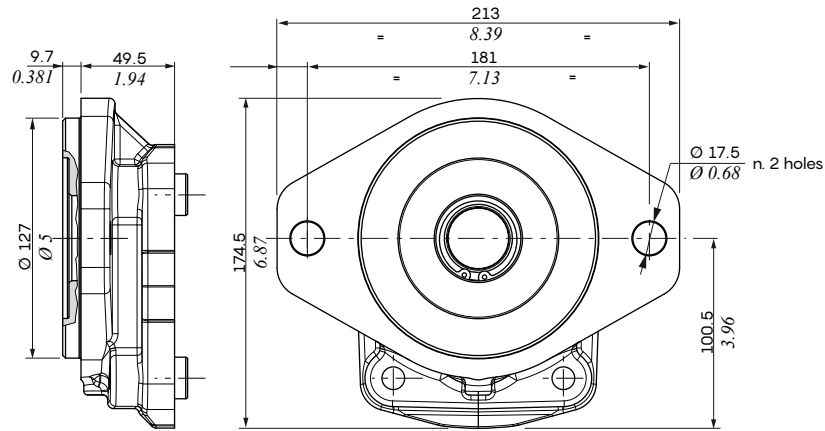

SAEC4F type dimensions

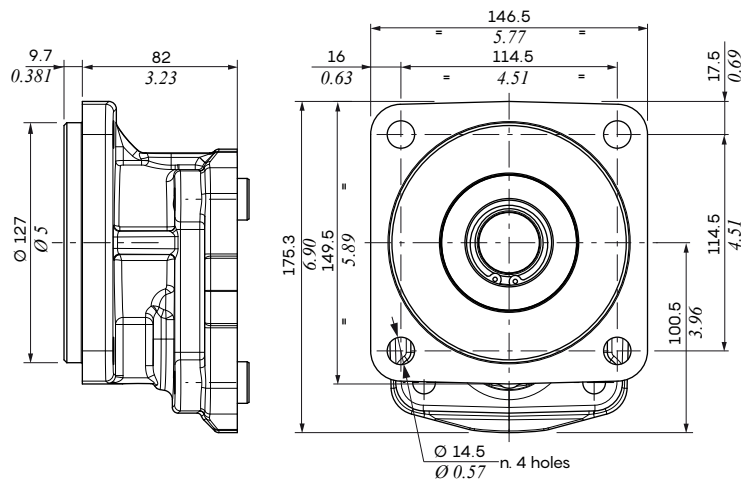

EUR type dimensions

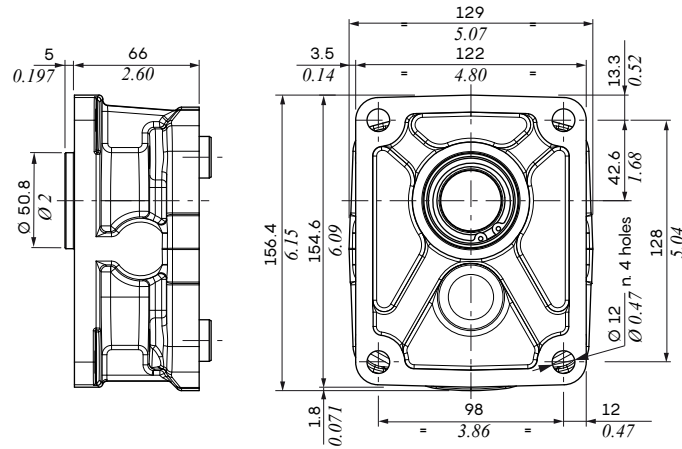

EUR(DREN) type dimensions

This configuration is available only for 3TMW motors; the position of the open port depends on the direction of rotation. For dimensions see EUR flange. The drain port is G3/8; for different threads contact Sales department.

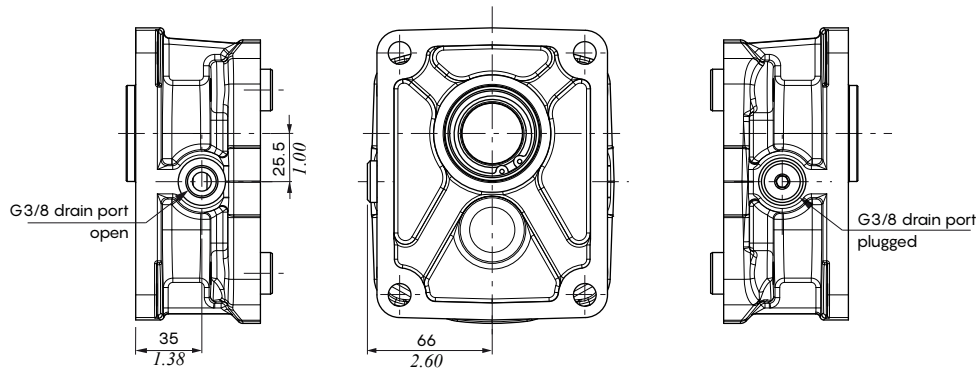

Gear thrust plate kits

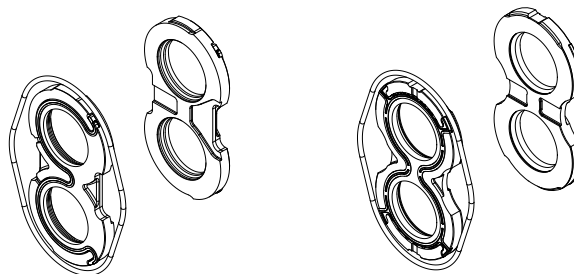

Ordering codes		
Seals material		
	Pumps and unidirectional motors	Reversible motors
NBR	N	5GKR3T0000
FPM	V	5GKR3T0001
		5GKR3T1000
		5GKR3T1001

Driving gear shafts

Type 10: tapered 1:8 shaft

Flange	Shaft dimension			
	A		B	
	mm	in	mm	in
EUR	47	1.85	32.6	1.28

Ordering codes	
Displacement	Codes
230	010043359399
280	010043447099
320	010043359299
390	010043359199
430	010043359099
470	010043358999
520	010043358899
560	010043358799
600	010043358699
650	010043358599
710	010043358499
790	010043358399
Shaft locking kit	003BG-10

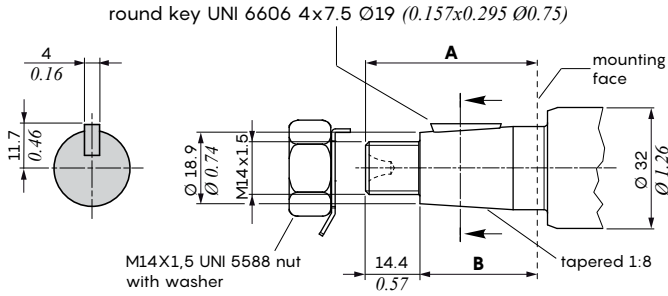

Max transmittable torque = 240 Nm - 178 lbft
 Nut tightening torque (M14x1.5) = 70 Nm - 51.6 lbft

Type 13: SAEB 13 parallel shaft

Flange	Shaft dimension			
	A		B	
	mm	in	mm	in
SAEB	41.2	1.62	33.3	1.31
SAEC2F	41.2	1.62	33.3	1.31

Ordering codes	
Displacement	Codes
230	010043439399
280	010043447199
320	010043439299
390	010043439199
430	010043439099
470	010043438999
520	010043438899
560	010043438799
600	010043438699
650	010043438599
710	010043438499
790	010043438399
Shaft key	010092715199

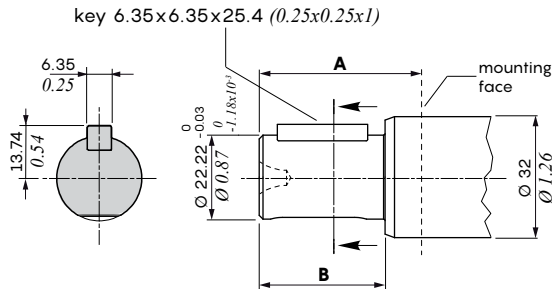

Max transmittable torque = 200 Nm - 148 lbft

Type S13: SAEB 13T splined shaft

Flange	Shaft dimension			
	A		B	
	mm	in	mm	in
SAEB	41	1.60	33	1.30
SAEC2F	41	1.60	33	1.30

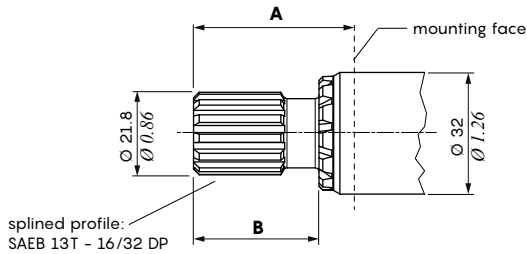

Ordering codes	
Displacement	Codes
230	010043354999
280	010043446599
320	010043354899
390	010043354799
430	010043354699
470	010043354599
520	010043354499
560	010043354399
600	010043354299
650	010043354199
710	010043354099
790	010043353999

Max transmittable torque = 280 Nm - 207 lbft

Type S13N: SAEB 13T splined NS shaft (increased torque)

This shaft is available only for configuration with single shaft seal (see page 15).

Flange	Shaft dimension			
	A		B	
	mm	in	mm	in
SAEB	41	1.60	33	1.30
SAEC2F	41	1.60	33	1.30

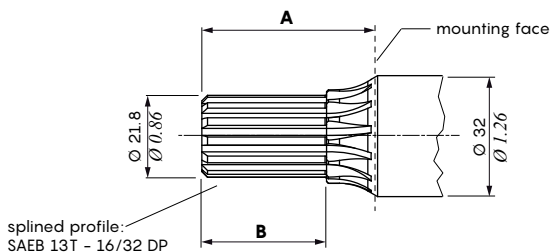

Ordering codes	
Displacement	Codes
230	010043360499
280	010043446699
320	010043360399
390	010043360299
430	010043360199
470	010043360099
520	010043359999
560	010043359899
600	010043359799
650	010043359699
710	010043359599
790	010043359499

Max transmittable torque = 300 Nm - 221 lbft

Driving gear shafts

Type S14 - S14L (long): SAEC 14T splined shaft

Shaft type	Flange	Shaft dimension			
		A		B	
		mm	in	mm	in
S14	SAEB	56	2.20	48	1.89
	SAEC2F	56	2.20	48	1.89
S14L	SAEC4F	56	2.20	48	1.89

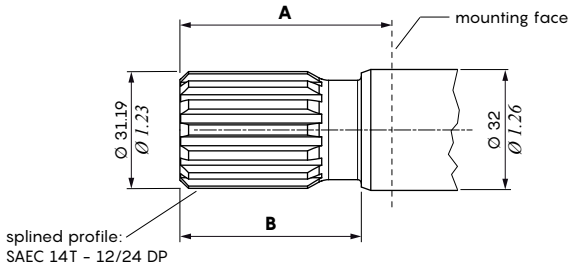

Max transmittable torque = 900 Nm - 664 lbft

Displacement	Ordering codes	
	Shaft type S14	Shaft type S14L
230	010043357199	010043358299
280	010043446899	010043446999
320	010043357099	010043358199
390	010043356999	010043358099
430	010043356899	010043357999
470	010043356799	010043357899
520	010043356699	010043357799
560	010043356599	010043357699
600	010043356499	010043357599
650	010043356399	010043357499
710	010043356299	010043357399
790	010043356199	010043357299

Type S15 - S15L (long): SAEC 15T splined shaft

Shaft type	Flange	Shaft dimension			
		A		B	
		mm	in	mm	in
S15	SAEB	46	1.81	38	1.50
	SAEC2F	46	1.81	38	1.50
S15L	SAEC4F	46	1.81	38	1.50

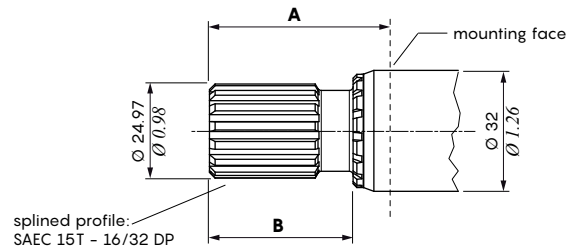

Max transmittable torque = 400 Nm - 269 lbft

Displacement	Ordering codes	
	Shaft type S15	Shaft type S15L
230	010043356099	010043362599
280	010043439799	010043446799
320	010043355999	010043362499
390	010043355899	010043362399
430	010043355799	010043362299
470	010043355699	010043362199
520	010043355599	010043362099
560	010043355499	010043361999
600	010043355399	010043361899
650	010043355299	010043361799
710	010043355199	010043361699
790	010043355099	010043361599

Ordering codes					
Displacement	Codes	Displacement	Codes	Displacement	Codes
230	010053367399	430	010053367099	600	010053366699
280	010053439899	470	010053366999	650	010053366599
320	010053367299	520	010053366899	710	010053366499
390	010053367199	560	010053366799	790	010053366399

Type G0

For ports dimensions see pages 18/19.

For pumps and unidirectional motors

Connection position 0 - side port

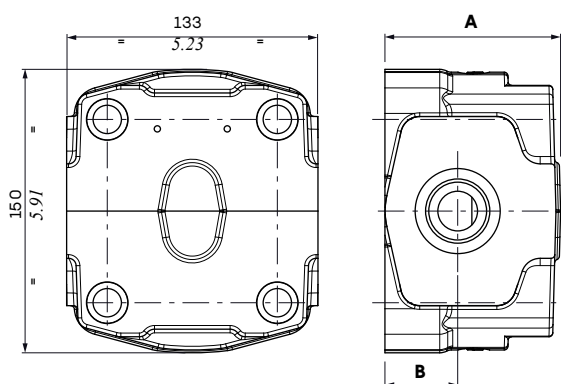

Displacement	Body dimension and port position								
	A		B						
	mm	in	Available connection ports*						
				type G-U-F		type N		type T	
		mm	in	mm	in	mm	in	mm	in
230	78.5	3.09	27	1.06	35	1.38	33	1.30	
280	81.5	3.21	30	1.18	35	1.38	33	1.30	
320	84.5	3.33	32	1.26	36	1.42	34	1.34	
390	90	3.54	36	1.42	37	1.45	36	1.41	
430	93	3.66	38.5	1.52	38	1.50	38.5	1.51	
470	96	3.78	41	1.61	39	1.54	41	1.51	
520	99	3.90	41	1.61	40	1.57	41	1.61	
560	102.5	4.04	42.5	1.67	40	1.57	42.5	1.67	
600	105.5	4.15	43.5	1.71	40	1.57	43.5	1.71	
650	108.5	4.27	44.5	1.76	44	1.73	44.5	1.76	
710	113.5	4.47	46	1.81	49	1.93	46	1.81	
790	119.5	4.70	52	2.05	50	1.97	52	2.05	

(*) G (BSP) - U (UN-UNF) - F (SAE flange) - N (European flange)
T (German flange)

Connection position 4 - rear port

Only for porting type G (BSP) - U (UN-UNF)

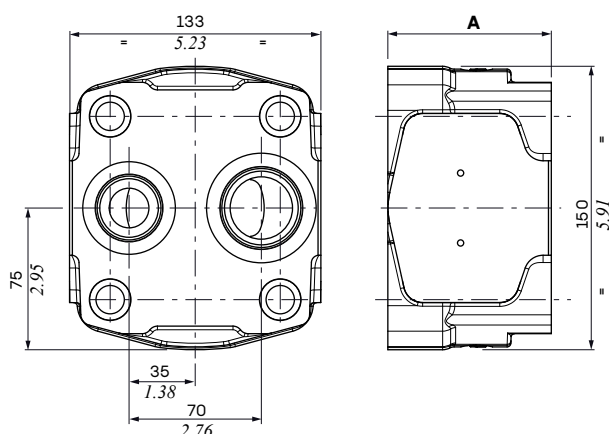

Displacement	Body dimension	
	A	
	mm	in
230	72	2.83
280	75	2.95
320	78	3.07
390	83.5	3.29
430	86.5	3.41
470	89.5	3.52
520	92.5	3.64
560	96	3.78
600	99	3.90
650	102	4.02
710	107	4.21
790	113	4.45

Standard bodies

Type G0

For ports dimensions see pages 18/19.

For reversible motors

Connection position 0 - side port

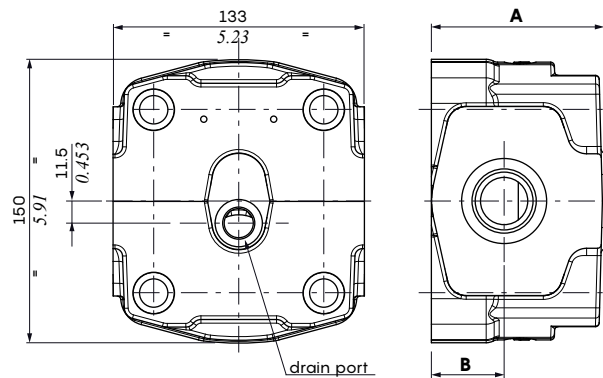

Displacement	Body dimension and port position							
	A		B					
			Available connection ports*					
	mm	in	type G-U-F		type N		type T	
	mm	in	mm	in	mm	in	mm	in
230	77	3.03	27	1.06	35	1.38	33	1.30
280	80	3.15	30	1.18	35	1.38	33	1.30
320	83	3.27	32	1.26	36	1.42	34	1.34
390	88.5	3.48	36	1.42	37	1.46	36	1.42
430	91.5	3.60	38.5	1.52	38	1.50	38.5	1.52
470	94.5	3.72	41	1.61	39	1.54	41	1.61
520	97.5	3.84	41	1.61	40	1.57	41	1.61
560	101	3.98	42.5	1.67	40	1.57	42.5	1.67
600	104	4.09	43.5	1.71	40	1.57	43.5	1.71
650	107	4.21	44.5	1.75	44	1.73	44.5	1.76
710	112	4.41	46	1.81	49	1.93	46	1.81
790	118	4.65	52	2.05	50	1.97	52	2.05

(*): G (BSP) - U (UN-UNF) - F (SAE flange) - N (European flange) - T (German T flange)

Type GOV - with auxiliary valves arrangement

Body with two valves arrangement, on left and right sides.
The GOV body is only available with F porting.

For reversible motors

Connection position 0 - side port

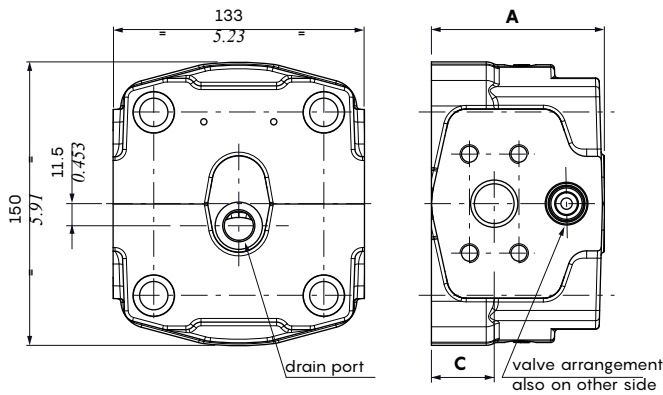

Displacement	Connection position 0 - side ports			
	A		C	
	mm	in	Available connection ports* type F	
	mm	in	mm	in
230	77	3.03	24.5	0.96
280	80	3.15	26.5	1.04
320	83	3.27	29.5	1.16
390	88.5	3.48	32	1.26
430	91.5	3.60	35	1.38
470	94.5	3.72	38	1.50
520	97.5	3.84	41	1.61
560	101	3.98	42.5	1.67
600	104	4.09	43.5	1.71
650	107	4.21	44.5	1.75
710	112	4.41	46	1.81
790	118	4.65	52	2.05

(*): F (SAE flange) - for different connection contact Sales Department

Description example:

3TMW- GOV -390-R-EUR(DREND)-K-N-10-0-F19F19- D C \ S U (160) - DRENG38-<CVN>

Stage type
GOV: with valves arrangement

Auxiliary valves position
D: valve on clockwise rotation
S: valve on counter-clockwise rotation

Auxiliary valves type
C: anticavitation valve
U: antishock+ anticavitation valves

Auxiliary valves setting
specify the setting value in bar

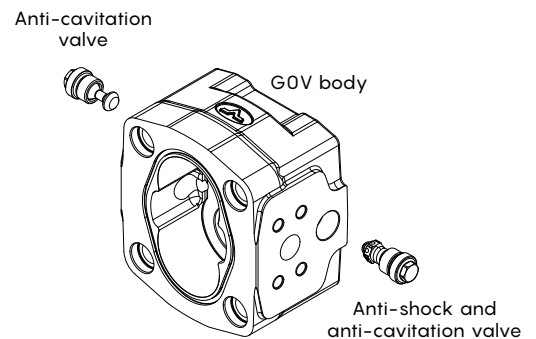
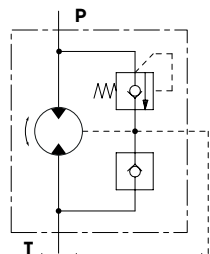
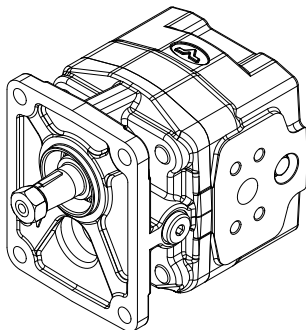

Special bodies

Type GOV - with auxiliary valves arrangement

Valves ordering codes				
Valve type	CODE	SYMBOL	DESCRIPTION	Tightening
TAP	XTAP522260F		Seat plug	Wrench 13 24 Nm (17.7 lbft)
	XTAP522441* XTAP522441V**		Valve blanking plug	Wrench 13 24 Nm (17.7 lbft)
C	5KIT410000* 5KIT410000V**		Anti-cavitation valve	Wrench 13 24 Nm (17.7 lbft)
U(...) setting (bar)	5KIT332...* 5KIT332...V** setting (bar)		Fixed setting anti-shock and anti-cavitation valves with pressure relief function Setting (bar - psi): 25 bar (363 psi) 30 bar (435 psi) 40 bar (580 psi) 50 bar (725 psi) 63 bar (914 psi) 80 bar (1150 psi) 100 bar (1450 psi) 110 bar (1590 psi) 125 bar (1800 psi) 140 bar (2050 psi) 150 bar (2150 psi) 160 bar (2300 psi) 175 bar (2550 psi) 190 bar (2750 psi) 200 bar (2900 psi) 210 bar (3050 psi) 220 bar (3190 psi) 230 bar (3350 psi) 240 bar (3500 psi) 250 bar (3600 psi) 260 bar (3750 psi) 270 bar (3900 psi) 280 bar (4050 psi) 290 bar (4200 psi) 300 bar (4350 psi) 310 bar (4500 psi) 320 bar (4650 psi) 340 bar (4950 psi) 360 bar (5200 psi) 400 bar (5800 psi) 420 bar (6100 psi)	Wrench 13 24 Nm (17.7 lbft)

NOTE: (*) code is referred to valve with NBR O-ring seals. (**) code is referred to valve with FPM O-ring seals.

Auxiliary valves characteristics

Anti-shock plus anti-cavitation valves setting example

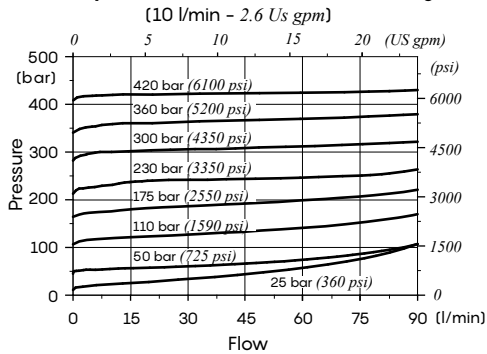

Anti-shock plus anti-cavitation valves pressure drop

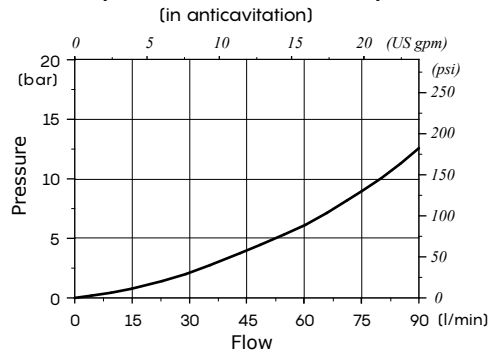

Anti-cavitation valve pressure drop

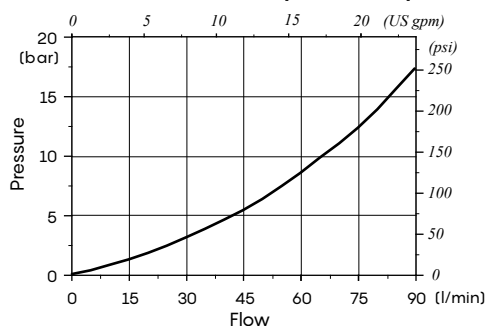

Type GOD - with tandem arrangement

This body option is the solution if you need a single pump but you want to have the possibility of transforming it into a multiple pump with common suction.

The body is dedicate for clockwise (**D**) or counter-clockwise (**S**) rotation and it can be configured with type **B** connection (only with ports pre-drilling)

For ports dimensions see pages 18/19, except for type **N**; with this porting all ports are **N19** dimension.

For pumps

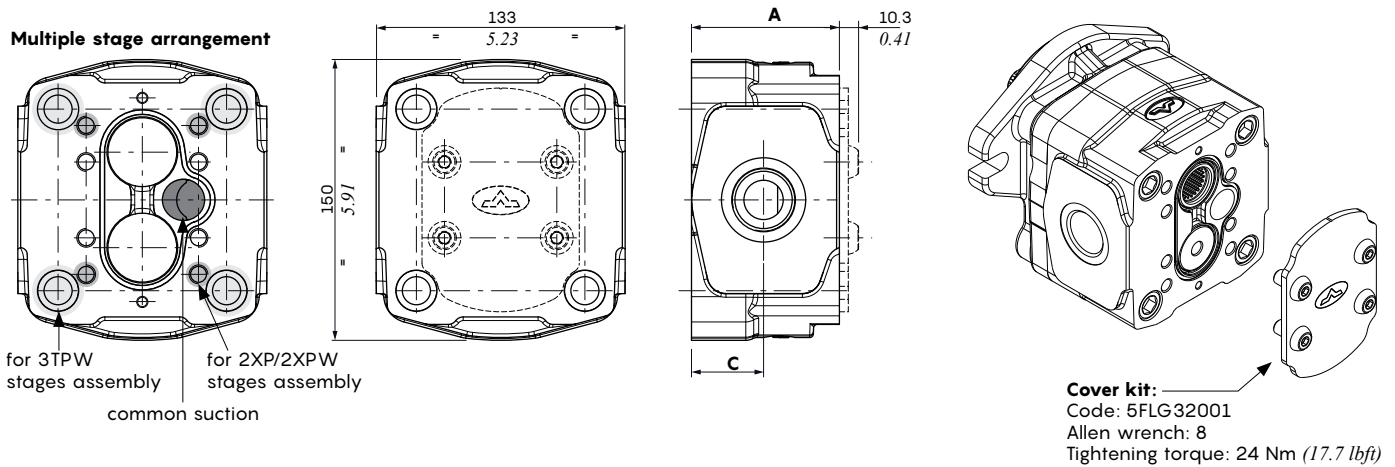

Displacement	Connection position 0 - side ports									
	A		C							
	mm	in	Available connection ports*							
			type G-U-F		type N		type T		type B	
			mm	in	mm	in	mm	in	mm	in
230	64.5	2.54	27	1.06	32	1.26	33	1.30	32	1.26
280	67.5	2.66	30	1.18	32	1.26	33	1.30	32	1.26
320	70.5	2.78	32	1.26	36	1.42	34	1.34	36	1.42
390	76	2.99	36	1.42	37	1.46	36	1.42	37	1.46
430	79	3.11	38.5	1.52	38	1.50	38.5	1.52	38	1.50
470	82	3.23	41	1.61	39	1.54	41	1.61	39	1.54
520	85	3.35	41	1.61	40	1.57	41	1.61	40	1.57
560	88.5	3.48	42.5	1.67	43	1.69	42.5	1.67	43	1.69
600	91.5	3.60	43.5	1.71	44	1.73	43.5	1.71	44	1.73
650	94.5	3.72	44.5	1.75	44	1.73	44.5	1.75	44	1.73
710	99.5	3.92	46	1.81	49	1.93	46	1.81	49	1.93
790	105.5	4.15	52	2.05	55	2.17	52	2.05	55	2.17

(*): **G** (BSP) - **U** (UN-UNF) - **F** (SAE flange) - **N** (European flange) - **T** (German flange)
B (ports arrangement, only initial bore)

Tandem pumps general informations

Walvoil allows tandem kit assembly in several different conditions.

As general indications:

- It is necessary to assemble the units from the largest to the smallest, in terms of power and torque required;
- Maximum rotation speed of multiple pump is equal to the unit with lowest maximum admissible speed.

When using and sizing a tandem pump there are two key points to consider:

1) Torque

Each tandem kit allows the transmission of maximum torque between stages.

It is important to check that the maximum transmitted torque remains below the value allowed by each tandem kit and main shaft.

The torque M of each stage can be calculated with the formula:

$$M = \frac{\Delta p \cdot V}{62.83 \cdot \eta_m}$$

Δp is the maximum pressure created by the circuit on each stage, V is the displacement and η_m is the mechanical efficiency.

As example consider a triple pump with shaft type S13N
3TPW430/TK/3TPW320/TK/3TPW230.

The maximum pressure peaks that the system can produce at the same time are: 150 bar (2150 psi), 200 bar (29600 psi), 120 bar (1750 psi)

In this working condition each required torque must be evaluated (an efficiency of 90% is considered).

Stage type	Working pressure		Torque		
	bar	psi	Formula	Nm	lbf·ft
3TPW430	150	2150	$M1 = \frac{150 \cdot 43.8}{62.83 \cdot 0.9}$	116	31.3
3TPW320	200	2600	$M2 = \frac{200 \cdot 32.2}{62.83 \cdot 0.9}$	114	18.8
3TPW230	120	1750	$M3 = \frac{120 \cdot 23.9}{62.83 \cdot 0.9}$	51	9.4

The main shaft shall transmit a torque **M1+M2+M3** (281 Nm - 207 lbf·ft) which must be lower than the limit of shaft type S13N (300 Nm - 221 lbf·ft).

The first tandem kit shall transmit a torque **M2+M3** (165 Nm - 122 lbf·ft) which shall be lower than the limit of the kit TK (500 Nm - 73.8 lbf·ft); in this case it is acceptable.

The second tandem kit shall transmit a torque **M3** (51 Nm - 37.6 lbf·ft) which shall be lower than the limit of the kit TK (500 Nm - 73.8 lbf·ft); in this case it is acceptable.

2) Suction

The tandem is always possible with separate suction; in this case each pump uses its own suction pipe.

A common suction feature is available with Walvoil gear pumps.

In the case of common suction, two main conditions must be met:

- Sizing of the common inlet.

In the suction pipe it is recommended to have a cross section that ensures an oil speed between 0.6 and 2 m/s.

- Internal connection between stages.

Each kit has a recommended maximum flow.

For example, the **3TPW+2XP** double stage pump with **TN** tandem kit allows a max flow of 24 l/min (6.3 US gpm) shared between the stages. This value is provided for each tandem kit and is valid under recommended service conditions.

In case one of the 2 above conditions is not met the pump can cavitate, reducing the life of the components.

3TPW+2XP/2XPW common drain pumps tandem

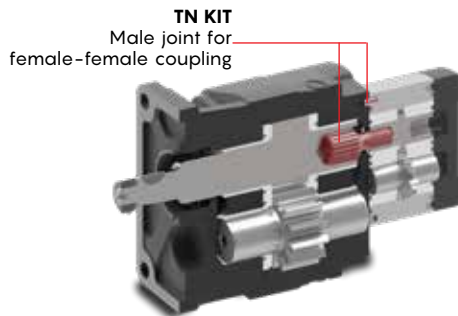

3TPW+3TPW common drain pumps tandem

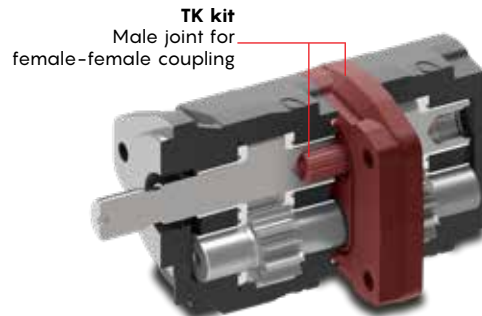

Tandem kits and bodies specifications

3TPW as primary stage, as 2X_ secondary stage

Xtreme Series pumps used as secondary stage.

3TPW + 2X_ tandem kits										
Primary stage + Secondary stage	Suction type	Kit type	CODE	Max. suction flow between stages		Max. transmittable torque		Drain connection	2 nd stage shaft type	Note
				l/min	US gpm	Nm	lbft			
3TPW(G2-0)+2XP/2XPW	separate	TN	5GKTN3200	-	-	100	73.8	Si	18F	
3TPW(G0D)+2XP/2XPW	separate	TK	5GKTK3200	-	-	100	73.8	Si	18F	
3TPW(G2-0U)+2XP(LAU)	common	TN	5GKTN3200	28	7.4	100	73.8	Si	18F	Secondary 2XP stage without suction port
3TPW(G2-0U)+2XPW	common	TN	5GKTN3200	28	7.4	100	73.8	Si	18F	Secondary 2XPW stage with suction port plugged
3TPW(G0D)+2XP(LAU)	common	TK	5GKTK3201	23	6.1	100	73.8	Si	18F	Secondary 2XP stage without suction port
3TPW(G0D)+2XPW	common	TK	5GKTK3201	23	6.1	100	73.8	Si	18F	Secondary 2XPW stage with suction port plugged

3TPW primary and secondary stage

Titan Series pumps can be used as primary and secondary stage.

3TPW + 2X_ tandem kits										
Primary stage + Secondary stage	Suction type	Kit type	CODE	Max. suction flow between stages		Max. transmittable torque		Drain connection	2 nd stage shaft type	Note
				l/min	US gpm	Nm	lbft			
3TPW(G3-0)+3TPW(G0)	separate	TN	5GKTK3300	-	-	500	369	Si	18F	
3TPW(G3-0U)+3TPW(G0)	common	TK	5GKTK3301	125	33	500	369	Si	18F	
3TPW(G0D)+3TPW(G0D)	common	TKD	5GKTK3302	70	18,5	500	369	Si	18F	2 nd stage body fitted with spacer kit

Dedicated 3TPW primary stage tandem bodies

Type G3-0

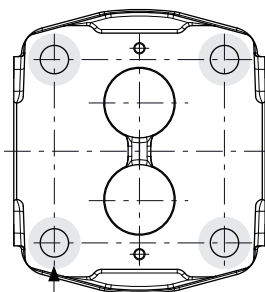

for 3TPW stages assembly

Type G3-0U

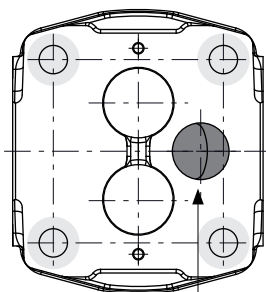

common suction

Type G2-0

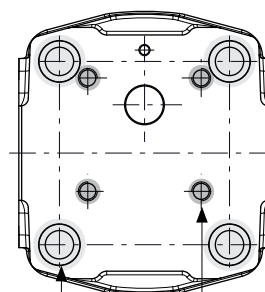

for 3TPW stages assembly for 2XP/2XPW stages assembly

Type G2-0U

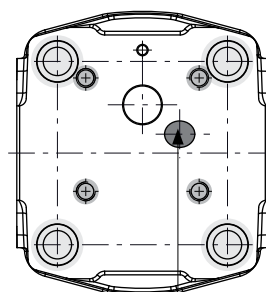

common suction

Type G0D

clockwise rotation

anti-clockwise rotation

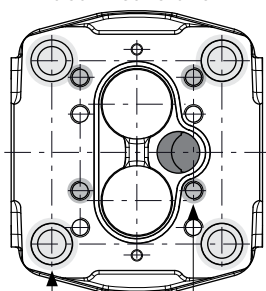

for 3TPW stages assembly for 2XP/2XPW stages assembly

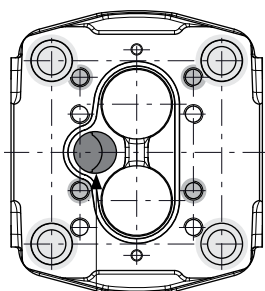

common suction

3TPW second stage dedicated driving gears

Type 18F

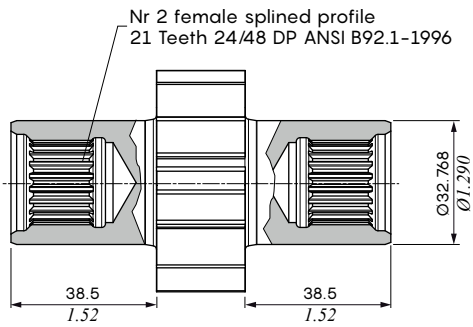

Driving gear shaft kit			
Displacement	Ordering codes	Displacement	Ordering codes
230	010043353899	520	010043353399
280	010043447299	560	010043353299
320	010043353799	600	010043353199
390	010043353699	650	010043353099
430	010043353599	710	010043352999
470	010043353499	790	010043352899

Max transmitted torque = 500 Nm - 369 lbf_t

2XP/2XPW secondary stage

Separate suction

Type TN tandem

This tandem consists of the first stage type 3TPW with G2-0 body and second standard stage 2XP or 2XPW.

NOTE: In order to install TN coupling kit it's necessary to disassembly the 3TPW main shaft.

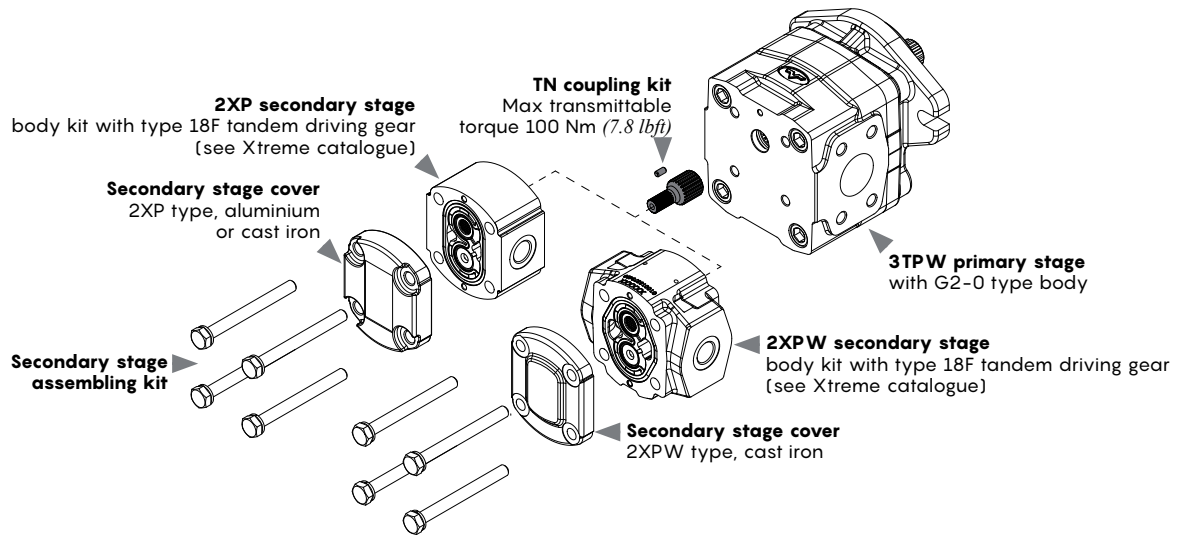

Description examples: 3TPW - **G2** - 650-D - SAEB-B-N-13- **0** - G114G1/2XP-A-140- **0** - G12G12

Stage body
Separate suction
Side suction and delivery ports

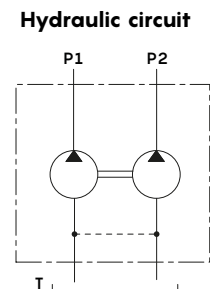
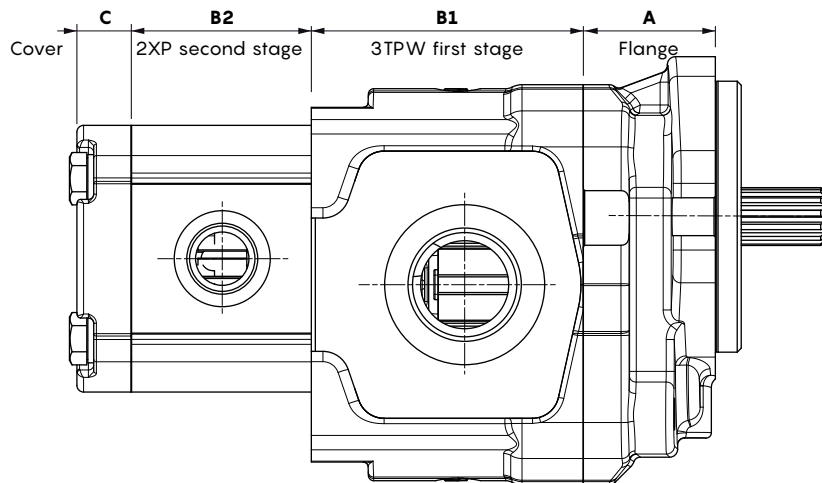

3TPW flange			3TPW(G2-0) body						2XP/2XPW body						2XP/2XPW cover			
Type	A		Displ.	B1		Displ.	B1		Displ.	B2		Displ.	B2		Port configuration	C		
	mm	in		mm	in		mm	in		mm	in		mm	in		mm	in	
SAEB	49.5	1.95	230	72	2.83	520	92.5	3.64	040*	50.8	2	190	76.6	3.01	0	aluminium*	20.5	0.81
SAEC-2F	49.5	1.95	280	75	2.99	560	96	3.78	060*	54.1	2.13	220	81.6	3.21		cast iron	18	0.71
SAEC-4F	82	3.23	320	78	3.07	600	99	3.90	080*	58.3	2.29	260	87.4	3.44	1 / 3 / 4	aluminium*	30	1.18
EUR	66	2.60	390	83.5	3.29	650	102	4.02	110	62.4	2.46	290	90.7	3.57		cast iron	29	0.97
			430	86.5	3.41	710	107	4.21	140	67.4	2.65	310	95.8	3.77				
			470	89.5	3.52	790	113	4.45	160	71.6	2.82							

(*) available only for 2XP type pump

2XP/2XPW secondary stage

Seperate suction

Type TK tandem

The configuration requires a tandem consisting of GOD type body for 3TPW first stage, the TK kit and standad second stage type 2XP or 2XPW.

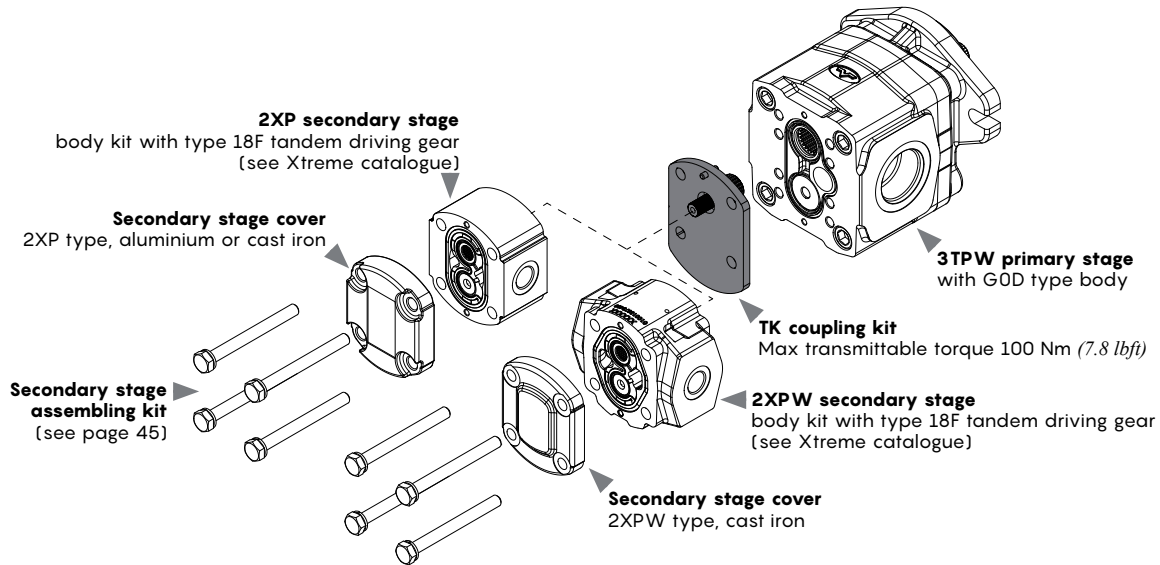

Description example: 3TPW- **GOD** -650-D-SAEB-B-N-10- **0** -G114G1/ **TK** /2XP-A-140- **0** -G34G12

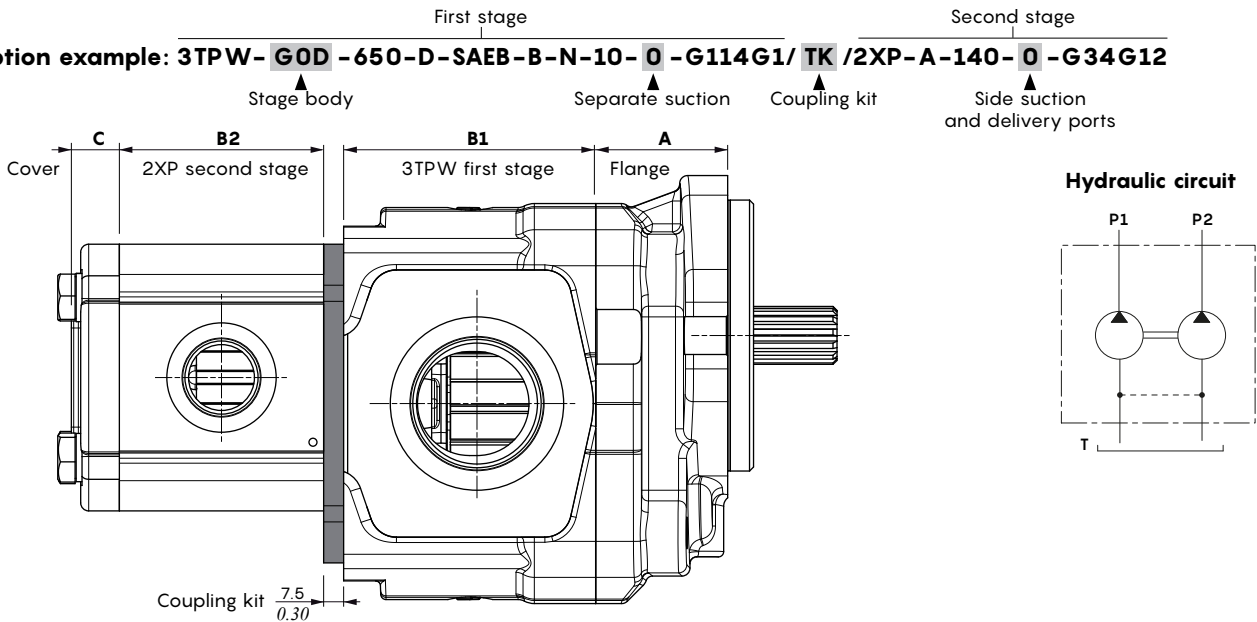

3TPW flange			3TPW-GOD body						2XP/2XPW body						2XP/2XPW cover				
Type	A		Displ.	B1		Displ.	B1	Displ.	B2		Displ.	B2		Port configuration	C				
	mm	in		mm	in				mm	in		mm	in		mm	in			
SAEB	49.5	1.95	230	64.5	2.54	520	85	3.35	040*	50.8	2	190	76.6	3.01	0	aluminium*	20.5	0.81	
SAEC-2F	49.5	1.95	280	67.5	2.66	560	88.5	3.48	060*	54.1	2.13	220	81.6	3.21		cast iron	18	0.71	
SAEC-4F	82	3.23	320	70.5	2.78	600	91.5	3.60	080*	58.3	2.29	260	87.4	3.44		1 / 3 / 4	aluminium*	30	1.18
EUR	66	2.60	390	76	2.99	650	94.5	3.72	110	62.4	2.46	290	90.7	3.57			cast iron	29	0.97
			430	79	3.11	710	99.5	3.92	140	67.4	2.65	310	95.8	3.77					
			470	82	3.23	790	105.5	4.15	160	71.6	2.82								

(*) available only for 2XP type pump

2XP/2XPW secondary stage

Common suction

Type TN tandem

This tandem consists of the first stage type 3TPW with G2-0U body, TN couplig kit, and second stage 2XP with LAU type body or 2XPW standard; max flow approx up to 28 l/min (7.4 US gpm).

NOTE: In order to install TN coupling kit it's necessary to disassembly the 3TPW main shaft.

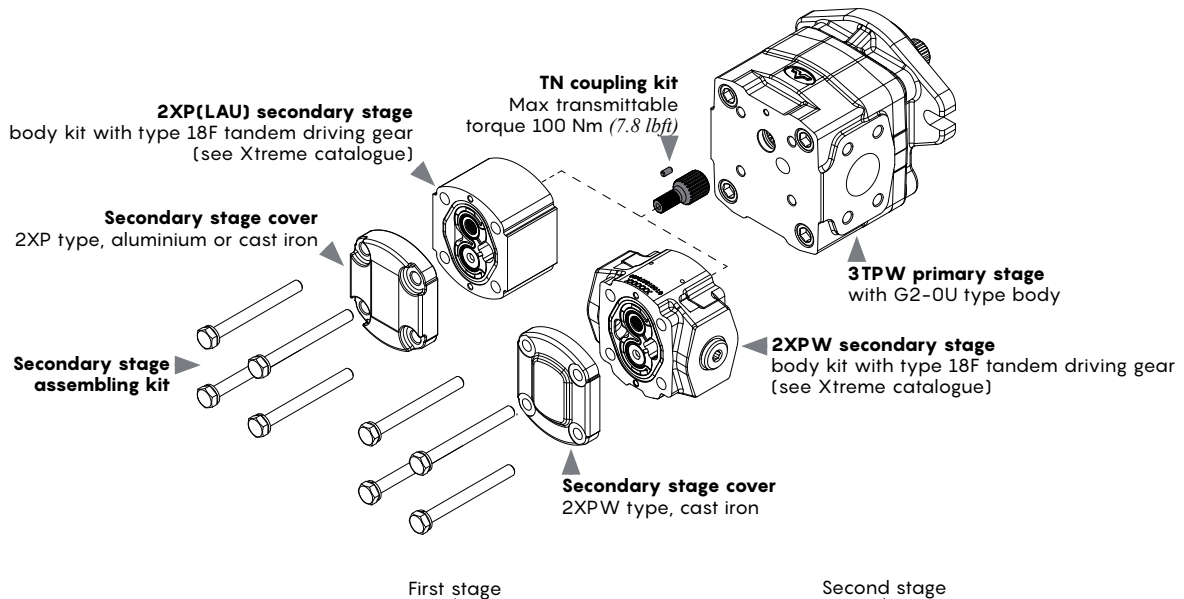

Description example: 3TPW- G2 - 650-D-SAEB-B-N-13- 0U -G114G1/2XP-A-140- OM -G12

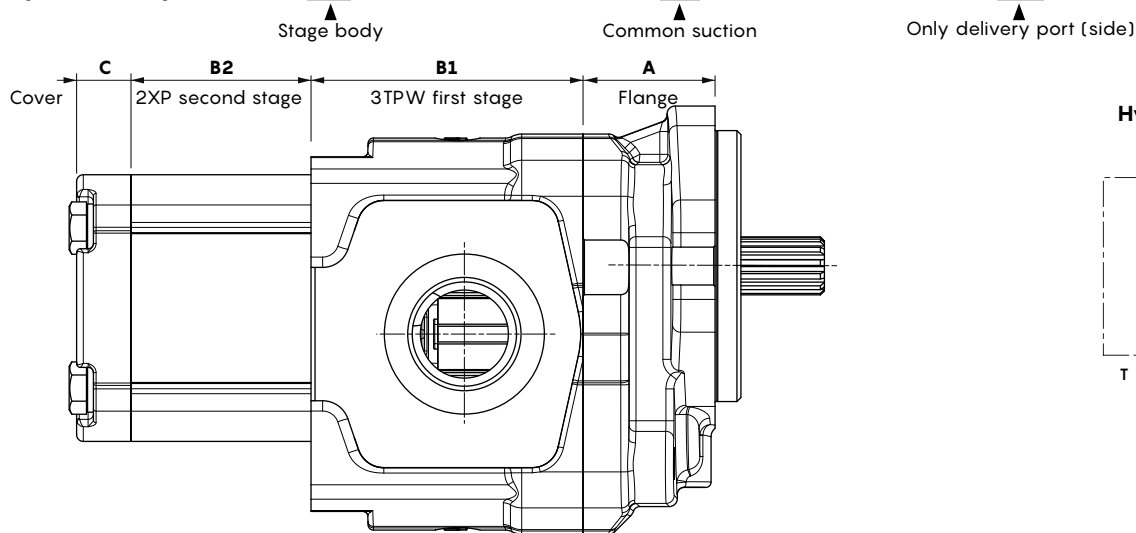

3TPW flange			3TPW(G2-0U) body						2XP(LAU)/2XPW body						2XP/2XPW cover			
Type	A		Displ.	B1		Displ.	B1		Displ.	B2		Displ.	B2		Port configuration	C		
	mm	in		mm	in		mm	in		mm	in		mm	in		mm	in	
SAEB	49.5	1.95	230	72	2.83	520	92.5	3.64	040*	50.8	2	190	76.6	3.01	0	aluminium*	20.5	0.81
SAEC-2F	49.5	1.95	280	75	2.99	560	96	3.78	060*	54.1	2.13	220	81.6	3.21		cast iron	18	0.71
SAEC-4F	82	3.23	320	78	3.07	600	99	3.90	080*	58.3	2.29	260	87.4	3.44	1 / 3 / 4	aluminium*	30	1.18
EUR	66	2.60	390	83.5	3.29	650	102	4.02	110	62.4	2.46	290	90.7	3.57		cast iron	29	0.97
			430	86.5	3.41	710	107	4.21	140	67.4	2.65	310	95.8	3.77				
			470	89.5	3.52	790	113	4.45	160	71.6	2.82							

(*) available only for 2XP type pump

2XP/2XPW secondary stage

Common suction

Type TK tandem

This tandem requires GOD type body with TKU kit and second stage type 2XP with LAU type body or 2XPW standard: max flow is 23 l/min (6.1 US gpm).

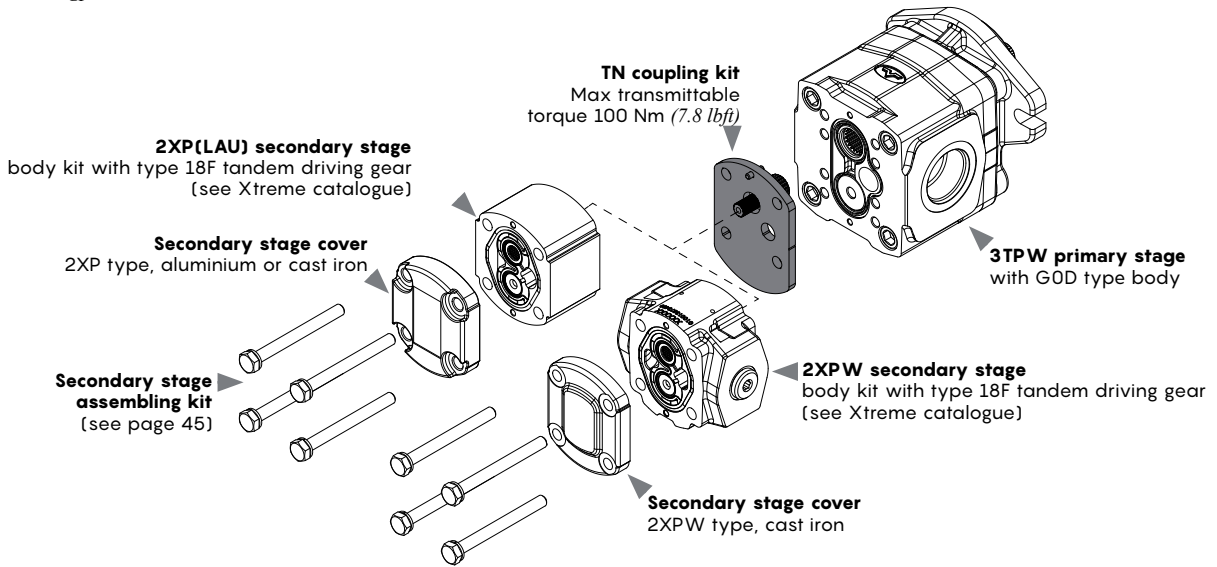

Description example: 3TPW-**GOD**-650-D-SAEB-B-N-10-**OU**-G114G1/**TK**/2XPW-G-110-**OM**-G12

Stage body Common suction Coupling kit Only delivery port (side)

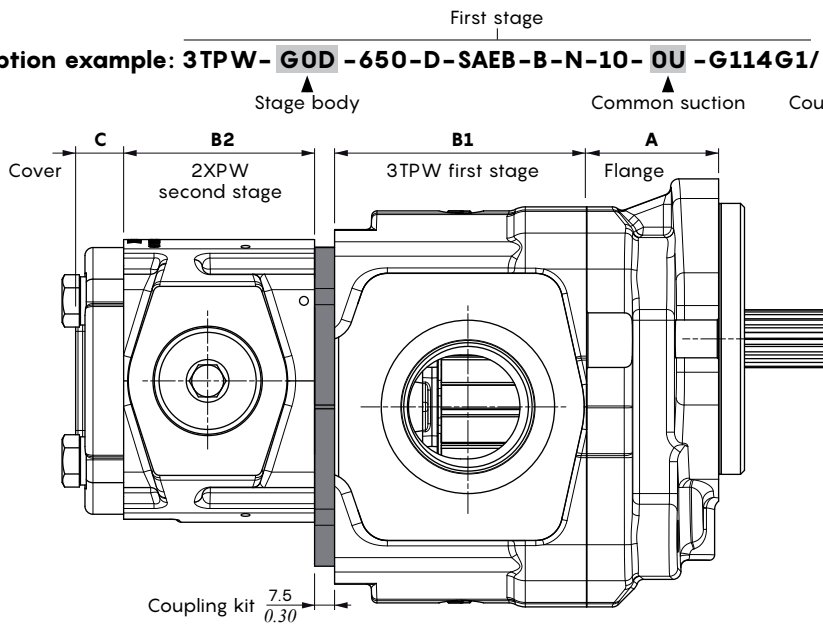

Hydraulic circuit

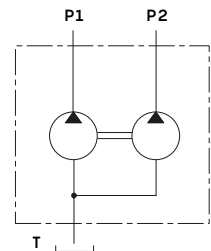

3TPW flange			3TPW-GOD body						2XP(LAU)/2XPW body						2XP/2XPW cover				
Type	A		Displ.	B1		Displ.	B1		Displ.	B2		Displ.	B2		Port configuration	C			
	mm	in		mm	in		mm	in		mm	in		mm	in		mm	in		
SAEB	49.5	1.95	230	64.5	2.54	520	85	3.35	040*	50.8	2	190	76.6	3.01	0	aluminium*	20.5	0.81	
SAEC-2F	49.5	1.95	280	67.5	2.66	560	88.5	3.48	060*	54.1	2.13	220	81.6	3.21		cast iron	18	0.71	
SAEC-4F	82	3.23	320	70.5	2.78	600	91.5	3.60	080*	58.3	2.29	260	87.4	3.44		1 / 3 / 4	aluminium	30	1.18
EUR	66	2.60	390	76	2.99	650	94.5	3.72	110	62.4	2.46	290	90.7	3.57			cast iron	29	0.97
			430	79	3.11	710	99.5	3.92	140	67.4	2.65	310	95.8	3.77					
			470	82	3.23	790	105.5	4.15	160	71.6	2.82								

(*) available only for 2XP type pump

3TPW primary and secondary stage

Separate suction

Type TK tandem

This tandem requires G3-0 type body for 3TPW first stage, G0 type body for 3TPW second stage and TK tandem kit between stages.

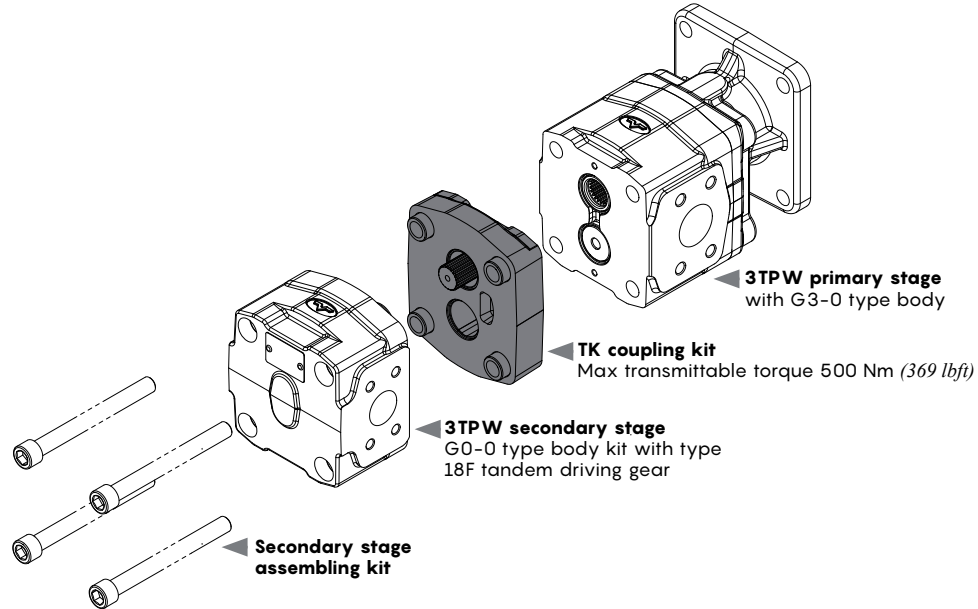

Description example: 3TPW- **G3** -710-D-SAEC4F-B-N-S14L- **0** -F39F32/ **TK** /3TPW- **G0** -320- **0** -F3219

Stage body Separate suction Coupling kit Stage body Suction and delivery ports (side)

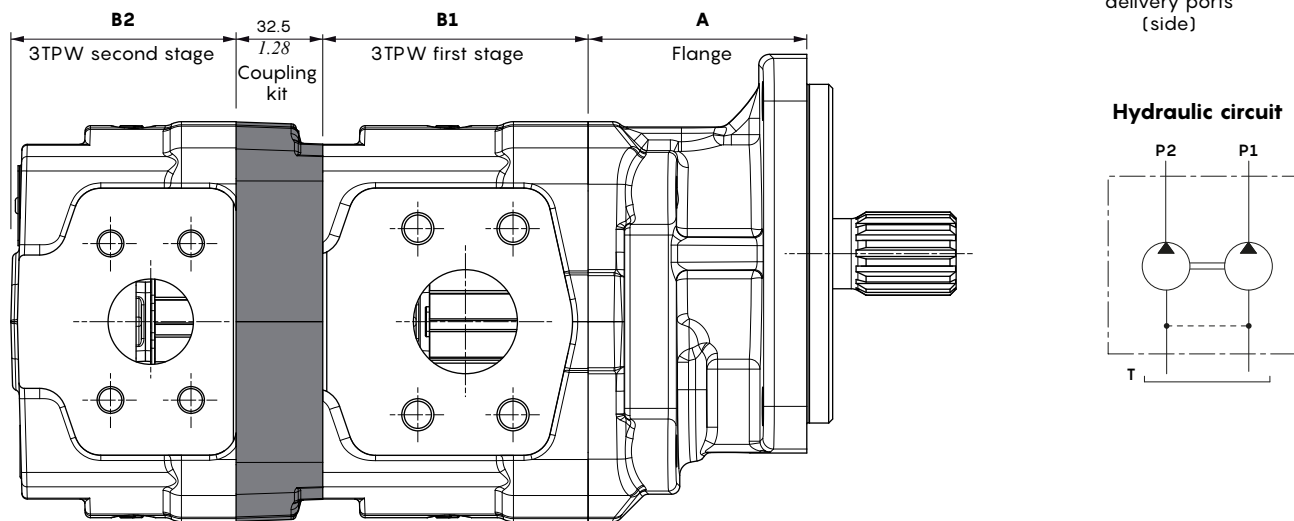

3TPW flange			3TPW(G3-0) body						3TPW-G0 body					
Type	A		Displ.	B1		Displ.	B1		Displ.	B2		Displ.	B2	
	mm	in		mm	in		mm	in		mm	in		mm	in
SAEB	49.5	1.95	230	64.5	2.54	520	85	3.35	230	78.5	3.09	520	99	3.90
SAEC-2F	49.5	1.95	280	67.5	2.66	560	88.5	3.48	280	81.5	3.21	560	102.5	4.04
SAEC-4F	82	3.23	320	70.5	2.78	600	91.5	3.60	320	84.5	3.33	600	105.5	4.15
EUR	66	2.60	390	76	2.99	650	94.5	3.72	390	90	3.54	650	108.5	4.27
			430	79	3.11	710	99.5	3.92	430	93	3.66	710	113.5	4.47
			470	82	3.23	790	105.5	4.15	470	96	3.80	790	119.5	4.70

3TPW primary and secondary stage

Common suction

Type TK tandem

This tandem requires G3-0U type body for 3TPW first stage, G0-0M type body for 3TPW second stage and TK tandem kit between stages.: max flow is 125 l/min (33 US gpm).

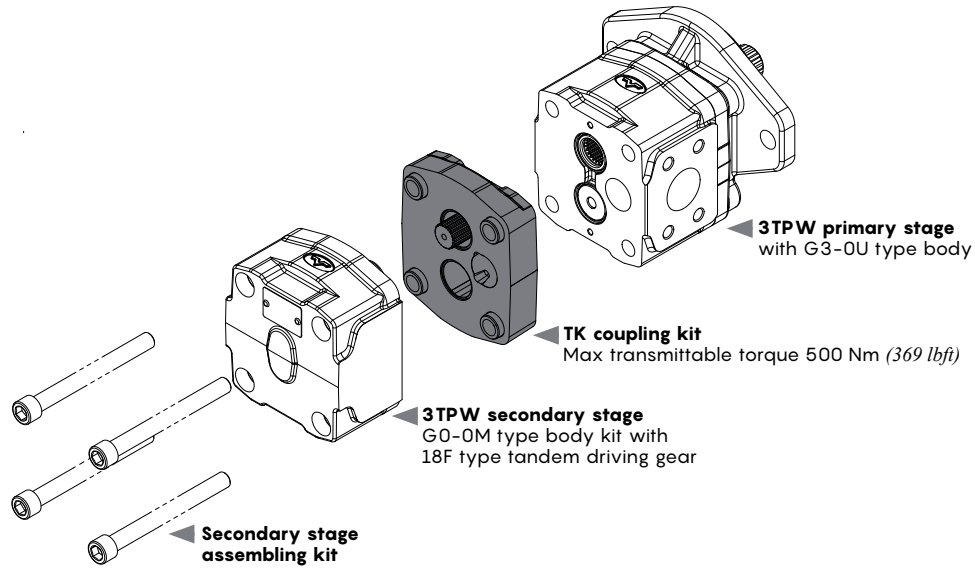

Description example: 3TPW- **G3** -710-D-SAEC4F-B-N-S14L- **OU** -F39F32/ **TK** /3TPW- **G0** -320- **OM** -F19

Stage body Common suction Coupling kit Stage body Only delivery port (side)

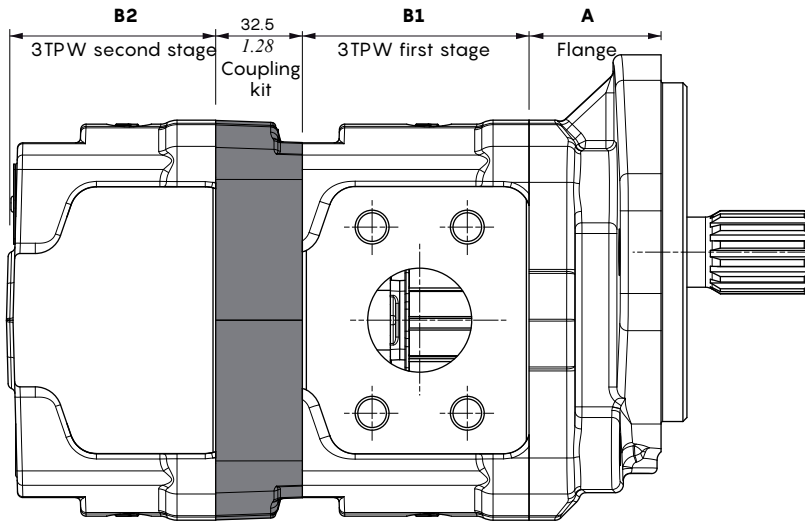

Hydraulic circuit

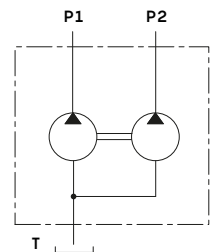

3TPW flange			3TPW(G3-0U) body						3TPW(G0-0M) body					
Type	A		Displ.	B1		Displ.	B1		Displ.	B2		Displ.	B2	
	mm	in		mm	in		mm	in		mm	in		mm	in
SAEB	49.5	1.95	230	64.5	2.54	520	85	3.35	230	78.5	3.09	520	99	3.90
SAEC-2F	49.5	1.95	280	67.5	2.66	560	88.5	3.48	280	81.5	3.21	560	102.5	4.04
SAEC-4F	82	3.23	320	70.5	2.78	600	91.5	3.60	320	84.5	3.33	600	105.5	4.15
EUR	66	2.60	390	76	2.99	650	94.5	3.72	390	90	3.54	650	108.5	4.27
			430	79	3.11	710	99.5	3.92	430	93	3.66	710	113.5	4.47
			470	82	3.23	790	105.5	4.15	470	96	3.80	790	119.5	4.70

Complete pumps ordering codes

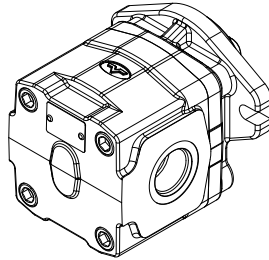

3TPW single stage pumps - Type G0 body

Flange type	Shaft type	Displacement	Code	Description	Notes		
SAEB	S13	230	1GP30010906	3TPW-G0-230-D-SAEB-B-N-S13-0-G1G34			
		280	1GP30011110	3TPW-G0-280-D-SAEB-B-N-S13-0-G1G34			
		320	1GP30010907	3TPW-G0-320-D-SAEB-B-N-S13-0-F32F19			
		390	1GP30010908	3TPW-G0-390-D-SAEB-B-N-S13-0-F32F19	- SAE flange ports		
		430	1GP30010909	3TPW-G0-430-D-SAEB-B-N-S13-0-F32F25	- NBR seals		
		470	1GP30010910	3TPW-G0-470-D-SAEB-B-N-S13-0-F39F25	- Type B shaft sealing		
		520	1GP30010911	3TPW-G0-520-D-SAEB-B-N-S13-0-F39F25	- Clockwise rotation		
		560	1GP30011294	3TPW-G0-560-D-SAEB-B-N-S13-0-F39F32			
		600	1GP30010913	3TPW-G0-600-D-SAEB-B-N-S13-0-F39F32			
		650	1GP30010914	3TPW-G0-650-D-SAEB-B-N-S13-0-G114G1			
		710	1GP30010915	3TPW-G0-710-D-SAEB-B-N-S13-0-G114G1	- BSP thread ports		
		790	1GP30010916	3TPW-G0-790-D-SAEB-B-N-S13-0-G114G1	- Other features are the same of previous codes		
		EUR	10	230	1GP30011206	3TPW-G0-230-D-EUR-B-N-10-0-G1G34	
				280	1GP30011207	3TPW-G0-280-D-EUR-B-N-10-0-G1G34	
320	1GP30011208			3TPW-G0-320-D-EUR-B-N-10-0-G14G1			
390	1GP30011079			3TPW-G0-390-D-EUR-B-N-10-0-G14G1			
430	on request			3TPW-G0-430-D-EUR-B-N-10-0-G14G1			
470	1GP30011209			3TPW-G0-470-D-EUR-B-N-10-0-G14G1	- BSP thread ports		
520	1GP30011210			3TPW-G0-520-D-EUR-B-N-10-0-G14G1	- NBR seals		
560	1GP30011054			3TPW-G0-560-D-EUR-B-N-10-0-G14G1	- Type B shaft sealing		
600	1GP30011211			3TPW-G0-600-D-EUR-B-N-10-0-G14G1	- Clockwise rotation		
650	1GP30011201			3TPW-G0-650-D-EUR-B-N-10-0-G114G1			
710	1GP30011212			3TPW-G0-710-D-EUR-B-N-10-0-G114G1			
790	1GP30011053	3TPW-G0-790-D-EUR-B-N-10-0-G114G1					

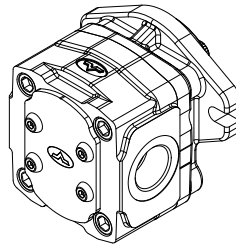

3TPW single stage pumps – Type GOD body					
Flange type	Shaft type	Displacement	Code	Description	Notes
SAEB	S13	230	1GP30011275	3TPW-GOD-230-D-SAEB-B-N-S15-0-F25F19	
		280	1GP30011276	3TPW-GOD-280-D-SAEB-B-N-S15-0-F25F19	
		320	1GP30011277	3TPW-GOD-320-D-SAEB-B-N-S15-0-F32F19	
		390	1GP30011278	3TPW-GOD-390-D-SAEB-B-N-S15-0-F32F19	- SAE flange ports
		430	1GP30011279	3TPW-GOD-430-D-SAEB-B-N-S15-0-F32F25	- NBR seals
		470	1GP30011302	3TPW-GOD-470-D-SAEB-B-N-S15-0-F39F25	- Type B shaft sealing
		520	1GP30011281	3TPW-GOD-520-D-SAEB-B-N-S15-0-F39F25	- Clockwise rotation
		560	1GP30011282	3TPW-GOD-560-D-SAEB-B-N-S15-0-F39F32	
		600	1GP30011274	3TPW-GOD-600-D-SAEB-B-N-S15-0-F39F32	
		650	on request	3TPW-GOD-650-D-SAEB-B-N-S15-0-G114G1	- BSP thread ports
		710	on request	3TPW-GOD-710-D-SAEB-B-N-S15-0-G114G1	- Other features are the same of previous codes
SAEB	S13N	320	1GP30011062	3TPW-GOD-320-D-SAEB-B-N-S13N-0-G114G1	
		430	1GP30011063	3TPW-GOD-430-D-SAEB-B-N-S13N-0-G114G1	- BSP thread ports
		520	1GP30011064	3TPW-GOD-520-D-SAEB-B-N-S13N-0-G114G1	- NBR seals
		600	1GP30011065	3TPW-GOD-600-D-SAEB-B-N-S13N-0-G114G1	- Type B shaft sealing
		710	1GP30011066	3TPW-GOD-710-D-SAEB-B-N-S13N-0-G114G1	- Clockwise rotation
SAEB	13	230	1GP30011141	3TPW-GOD-230-D-SAEB-B-N-13-0-B19B13	
		280	1GP30011175	3TPW-GOD-280-D-SAEB-B-N-13-0-B19B13	
		320	1GP30011142	3TPW-GOD-320-D-SAEB-B-N-13-0-B27B19	
		390	on request	3TPW-GOD-390-D-SAEB-B-N-13-0-B27B19	
		430	1GP30011144	3TPW-GOD-430-D-SAEB-B-N-13-0-B27B19	
		470	on request	3TPW-GOD-470-D-SAEB-B-N-13-0-B27B19	- Port arrangement
		520	1GP30011146	3TPW-GOD-520-D-SAEB-B-N-13-0-B27B19	- NBR seals
		560	1GP30011147	3TPW-GOD-560-D-SAEB-B-N-13-0-B27B19	- Type B shaft sealing
		600	1GP30011148	3TPW-GOD-600-D-SAEB-B-N-13-0-B27B19	- Clockwise rotation
		650	1GP30011149	3TPW-GOD-650-D-SAEB-B-N-13-0-B19B13	
EUR	10	230	1GP30011119	3TPW-GOD-230-D-EUR-B-N-10-0-G1G34	
		280	1GP30011058	3TPW-GOD-280-D-EUR-B-N-10-0-G1G34	
		320	1GP30011120	3TPW-GOD-320-D-EUR-B-N-10-0-G114G1	
		390	1GP30011060	3TPW-GOD-390-D-EUR-B-N-10-0-G114G1	
		430	1GP30011121	3TPW-GOD-430-D-EUR-B-N-10-0-G114G1	
		470	1GP30011059	3TPW-GOD-470-D-EUR-B-N-10-0-G114G1	- BSP thread ports
		520	1GP30011122	3TPW-GOD-520-D-EUR-B-N-10-0-G114G1	- NBR seals
		560	1GP30011123	3TPW-GOD-560-D-EUR-B-N-10-0-G114G1	- Type B shaft sealing
		600	1GP30011124	3TPW-GOD-600-D-EUR-B-N-10-0-G114G1	- Clockwise rotation
		650	1GP30011125	3TPW-GOD-650-D-EUR-B-N-10-0-G114G1	
		710	1GP30011126	3TPW-GOD-710-D-EUR-B-N-10-0-G114G1	
		790	1GP30011061	3TPW-GOD-790-D-EUR-B-N-10-0-G114G1	

Secondary stage ordering codes

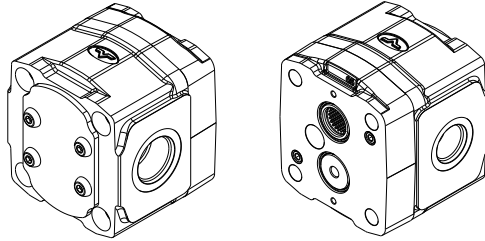

3TPW pumps secondary stage - Type GOD body				
Ports type	Shaft type	Displacement	Code	Description
BSP thread	18F	230	5GKBP3T012	3TPW-G0D-230-D-TKD-N-18F-0-G1G34 Stage
		280	5GKBP3T013	3TPW-G0D-280-D-TKD-N-18F-0-G1G34 Stage
		320	5GKBP3T014	3TPW-G0D-320-D-TKD-N-18F-0-G114G1 Stage
		390	5GKBP3T015	3TPW-G0D-390-D-TKD-N-18F-0-G114G1 Stage
		430	5GKBP3T016	3TPW-G0D-430-D-TKD-N-18F-0-G114G1 Stage
		470	5GKBP3T017	3TPW-G0D-470-D-TKD-N-18F-0-G114G1 Stage
		520	5GKBP3T018	3TPW-G0D-520-D-TKD-N-18F-0-G114G1 Stage
		560	5GKBP3T019	3TPW-G0D-560-D-TKD-N-18F-0-G114G1 Stage
		600	5GKBP3T020	3TPW-G0D-600-D-TKD-N-18F-0-G114G1 Stage
		650	5GKBP3T021	3TPW-G0D-650-D-TKD-N-18F-0-G114G1 Stage
		710	5GKBP3T022	3TPW-G0D-710-D-TKD-N-18F-0-G114G1 Stage
		790	5GKBP3T023	3TPW-G0D-790-D-TKD-N-18F-0-G114G1 Stage
SAE flange	18F	280	5GKBP3T073	3TPW-G0D-280-D-TKD-N-18F-0-F25F19 Stage
		320	5GKBP3T074	3TPW-G0D-320-D-TKD-N-18F-0-F32F19 Stage
		390	5GKBP3T075	3TPW-G0D-390-D-TKD-N-18F-0-F32F19 Stage
		430	5GKBP3T076	3TPW-G0D-430-D-TKD-N-18F-0-F32F19 Stage
		470	5GKBP3T077	3TPW-G0D-470-D-TKD-N-18F-0-F39F25 Stage
		520	5GKBP3T078	3TPW-G0D-520-D-TKD-N-18F-0-F39F25 Stage

Assembling screws ordering codes

The length of the screws indicated in the tables below refers to tandem pumps/motors configured with **G0D** body; for different configuration contact our Sales Department.

To correctly order the assembly screws it is necessary to calculate the tandem length as shown in the picture.

3TPW+2XP/2XPW tandem

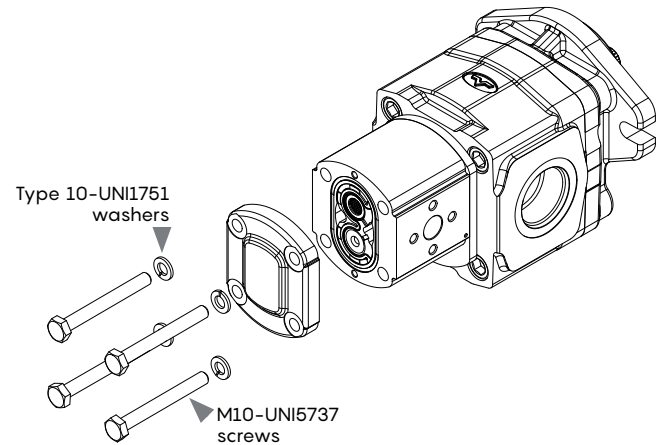
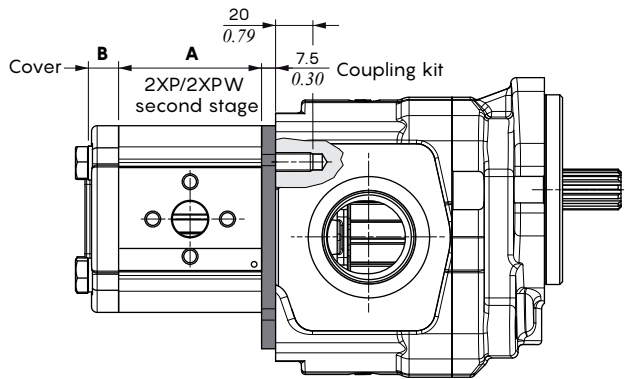

2XP/2XPW body			2XP/2XPW cover (washer dimension included)		
Displacement	A		Port configuration	B	
	mm	in		mm	in
040*	50.8	2	0	aluminium*	16.4 0.65
060*	54.1	2.13		cast iron	16.2 0.64
080*	58.3	2.29	1 / 3 / 4	aluminium*	16.4 0.65
110	62.4	2.46		cast iron	18.2 0.72
140	67.4	2.65	For special covers see Xtreme Series catalogue		
160	71.6	2.82	(*) available only for 2XP type pump		
190	76.6	3.01			
220	81.6	3.21			
260	87.4	3.44			
290	90.7	3.57			
310	95.8	3.77			

UNI 5737-10.9 screws ordering codes	
Length mm (in)	Code
M10x85 (3.35)	107010085
M10x90 (3.54)	107010090
M10x95 (3.74)	107010095
M10x100 (3.94)	107010100
M10x105 (4.13)	107010105
M10x110 (4.33)	107010110
M10x115 (4.53)	107010115
M10x120 (4.72)	107010120
M10x125 (4.92)	107010125
M10x130 (5.12)	107010130
Type 10-UNI1751 washer	4RS2102201

Assembling screws ordering codes

3TPW+3TPW tandem

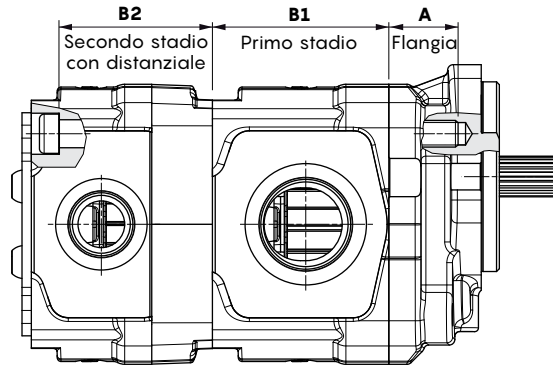

3TPW flange		
Type	A	
	mm	in
SAEB	37	1.46
SAEC-2F	37	1.46
SAEC-4F	33	1.30
EUR	26.2	1.03

3TPW-GOD bodies						
Displacement	B1				B2	
	mm	in	mm	in	mm	in
230	64.5	2.54	82	3.23		
280	67.5	2.66	85	3.35		
320	70.5	2.78	88	3.46		
390	76	2.99	93.5	3.68		
430	79	3.11	96.5	3.80		
470	82	3.23	99.5	3.92		
520	85	3.35	102.5	4.04		
560	88.5	3.48	106	4.17		
600	91.5	3.60	109	4.29		
650	94.5	3.72	112	4.41		
710	99.5	3.92	117	4.61		
790	105.5	4.15	123	4.84		

UNI 5931-12.9 screws ordering codes	
Lenght mm (in)	Code
M14x175 (6.89)	4VT2721750
M14x180 (7.09)	4VT2721800
M14x185 (7.28)	4VT2721850
M14x190 (7.48)	4VT2721901
M14x195 (7.68)	4VT2721950
M14x200 (7.87)	4VT2722001
M14x205 (8.07)	4VT2722050
M14x210 (8.27)	4VT2722101
M14x215 (8.46)	4VT2722151
M14x220 (8.66)	4VT2722201
M14x225 (8.86)	4VT2722250
M14x230 (9.06)	4VT2722301
M14x235 (9.25)	4VT2722351
M14x240 (9.45)	4VT2722401
M14x245 (9.65)	4VT2722451
M14x250 (9.84)	4VT2722501
M14x255 (10.04)	4VT2722550
M14x260 (10.24)	4VT2722601

Product identification



WALVOIL NEL MONDO | WALVOIL WORLDWIDE

WALVOIL S.P.A.

DIREZIONE E COORDINAMENTO INTERPUMP GROUP S.P.A.

Sede principale, Filiali e Uffici di rappresentanza
Headquarters, Subsidiaries and Representative Offices

WALVOIL S.P.A. SEDE PRINCIPALE | HEADQUARTERS

Via Adige, 13/D. 42124 Reggio Emilia. Italy
TEL. +39 0522 932411
info@walvoil.com | www.walvoil.com

AUSTRALASIA | AUSTRALASIA

WALVOIL FLUID POWER AUSTRALASIA PTY LTD

6 Leonard Avenue. Toukley NSW 2263. Sydney. Australia
TEL. +61 413 739 938
australasia@walvoil.com

BRASILE | BRAZIL

INTERPUMP HYDRAULICS BRASIL LTDA | WALVOIL DIVISION

Rua Gilberto de Zorzi, 525. Bairro Forqueta 95115-730
Caxias do Sul (RS)
TEL. +55 54 3289 7000
infobrasil@walvoil.com

CANADA | CANADA

WALVOIL CANADA INC.

3100, Rue Jacob Jordan. Terrebonne. Qc J6X 4J6. Canada
TEL. +1 450 477 1076 Ext:225
info@walvoilcanada.com | www.walvoilcanada.com

CINA | CHINA

WALVOIL FLUID POWER (DONGGUAN) CO. LTD

1st Floor, the Third Factory Area, Sijia, Shijie Town, Dongguan City
Guangdong province. China.
TEL. +86 769 81816189-8020
info@walvoil.com.cn | www.walvoil.com.cn

COREA DEL SUD | SOUTH KOREA

WALVOIL FLUID POWER KOREA LTD.

(17818)80-15, Oseongsandan 1Ro, Oseong-myun,
Pyeongtaek-si Gyeonggi-do
Republic of Korea 451-872
TEL. +82 31 682 6030
info@walvoil.co.kr | www.walvoil.co.kr

FRANCIA | FRANCE

WALVOIL FLUID POWER FRANCE

362 rue de La Jaunais. Vritz. 44540 Vallons-de-l'Erdre
TEL. +33 2 41 94 41 06
france@walvoil.com

INDIA | INDIA

WALVOIL FLUID POWER (INDIA) PVT. LTD.

No. 1, 2nd Cross, 2nd Main, KIADB Industrial Area, Attibele, Anekal Taluk
Bangalore - 562107.
TEL. +91 80 0614 24000
info@walvoil.co.in | www.walvoil.co.in

MESSICO | MEXICO

WALVOIL FLUID POWER MEXICO S.A. DE C.V.

Calle Julian Sepulveda Davila #109
CP. 66640. Apodaca
Nuevo León. Mexico

U.S.A. | U.S.A.

WALVOIL FLUID POWER CORP. | HEADQUARTERS

4111 North Garnett Tulsa, OK 74116, USA
TEL. +1 918 858 7100
info@walvoilusa.com | www.walvoilusa.com

WALVOIL FLUID POWER CORP

1109, Technology Drive. Red Wing. MN 55066. U.S.A.
TEL. +1 651 212 6400
info@walvoilusa.com | www.walvoilusa.com



D2WWEM03A
1st edition May 2026

