



SDM 102

MONOBLOCK
DIRECTIONAL CONTROL VALVE



 **walvoil**
HYDRAULIC CONTROL SYSTEMS

Features

Simple, compact and heavy duty designed 2 sections monoblock valve are used in Front Loader application with open center and closed center hydraulic systems.

H Parallel circuit.

H Fitted with a main pressure relief valve and a load check valve on every working section.

H Available with manual and remote with flexible cables spool control kits.

H Diameter 16 mm - 0.63 in interchangeable spools.

H Available with service valve prearrangement.

H Optional power beyond port.

Additional information

This catalog shows the product in the most standard configurations.

Please contact Customer Service Dpt. for more detailed information or special request.

WARNING!

All specifications of this catalog refer to the standard product at this date.

Walvoil, oriented to a continuous improvement, reserves the right to discontinue, modify or revise the specifications, without notice.

WALVOIL IS NOT RESPONSIBLE FOR ANY DAMAGE CAUSED BY AN INCORRECT USE OF THE PRODUCT.

3rd edition December 2000:

This edition supercedes all prior documents.

Contents

Working conditions	4
Dimensional data	5
Hydraulic circuit	6
Performance data	7
Ordering codes	8
Inlet relief options	10
Spool options	11
"A" side spool positioners	14
"B" side options	15
Port relief options	18
Outlet conversion port options	20
Installation and maintenance	21

Working conditions

This catalog shows technical specifications and diagrams measured with mineral oil of 46 mm²/s - 46 cSt viscosity at 40°C - 104°F temperature.

Nominal flow rating		45 l/min	12 US gpm
Operating pressure (maximum)		250 bar	3600 psi
Max. back pressure	on outlet port T	25 bar	360 psi
Internal leakage A(B)→T	$\Delta p=100 \text{ bar} - 1450 \text{ psi}$ fluid and valve at 40°C - 104°F	3 cm ³ /min	0.18 in ³ /min
Fluid		Mineral oil	
Fluid temperature range	with NBR (BUNA-N) seals	from -20° to 80°C	from -4° to 176°F
	with FPM (VITON) seals	from -20° to 100°C	from -4° to 212°F
Viscosity	operating range	from 15 to 75 mm ² /s	from 15 to 75 cSt
	min.	12 mm ² /s	12 cSt
	max.	400 mm ² /s	400 cSt
Max level of contamination		19/16 - ISO 4406	NAS 1638 - class10
Ambient temperature range		from -40° to 60°C	from -40° to 140°F

NOTE - For different conditions please contact Customer Service.

Production batch :
 P00 = production year (2000)
 00001 = progressive number

WALVOIL
P0000001
102020002
MADE IN ITALY

Valve code

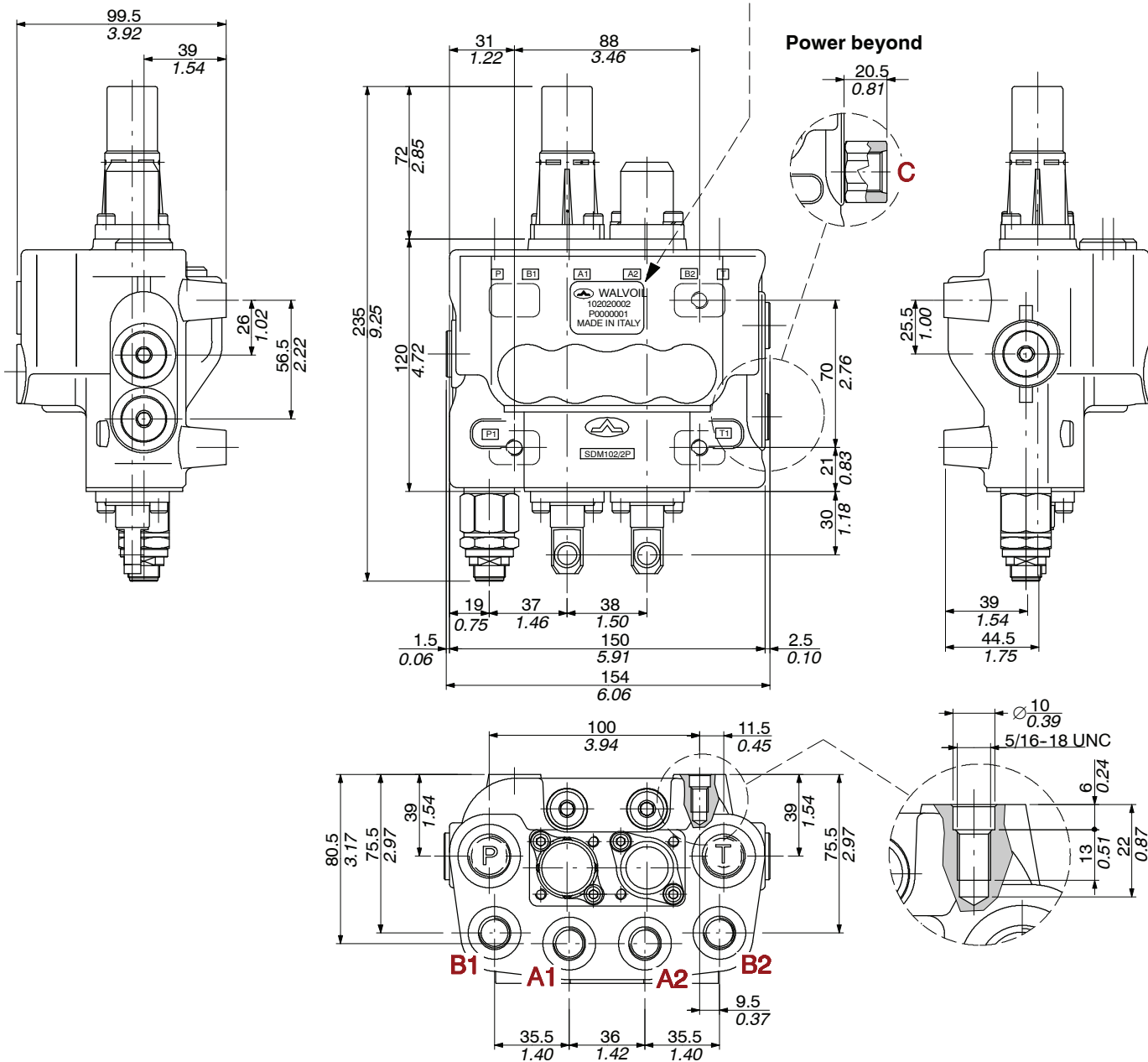

Standard threads

PORTS	BSP (ISO 228/1)	UN-UNF (ISO 11926-1)	METRIC (ISO 262)
Inlet P and power beyond C		3/4-16 UNF-2B (SAE 8)	
A and B ports	G 3/8	9/16-18 UNF-2B (SAE 6)	M18x1.5
Outlet T		3/4-16 UNF-2B (SAE 8)	

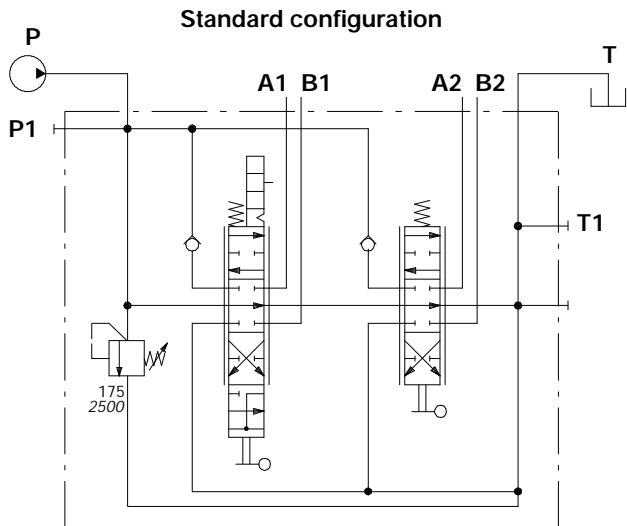
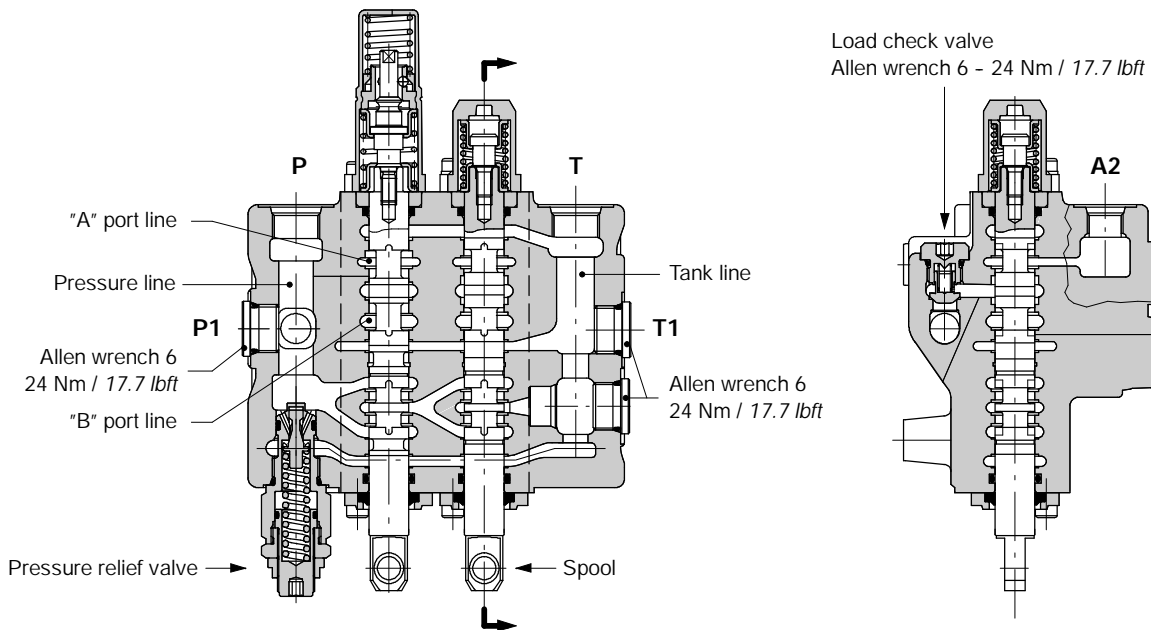

Ex.:
SDM102/2-P(TG3-175)/513RSLP/18MCSLP/
AET-PSC-<CVN>

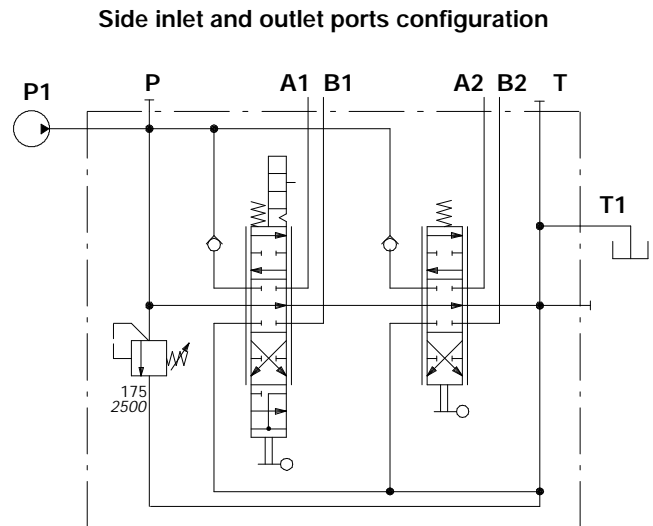

Ex.:
SDM102/2-P(TG3-175)/513RSLP/18MCSLP/
AET-PSL-<CVN>

Performance data (pressure drop vs. flow)

Open center

From cap side inlet to outlet (PSC configuration).

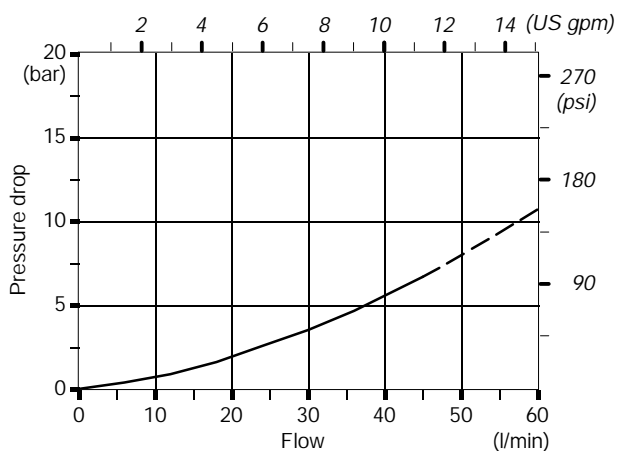
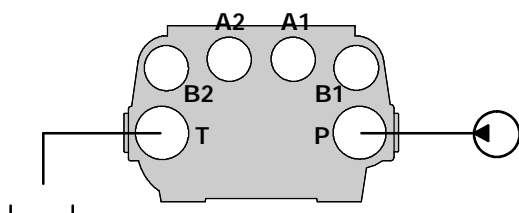

Inlet to work port

From cap side inlet to A port (spool in position 1) or B port (spool in position 2).

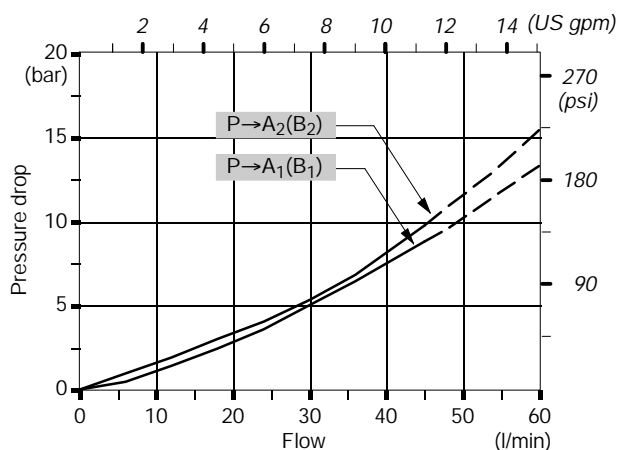
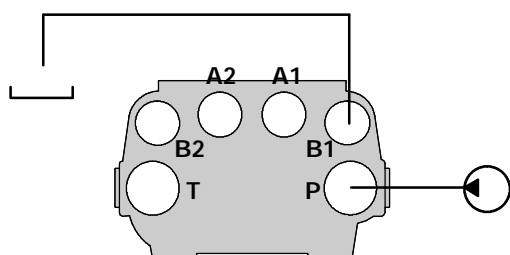

Work port to outlet

From A port (spool in position 2) or B port (spool in position 1) to outlet

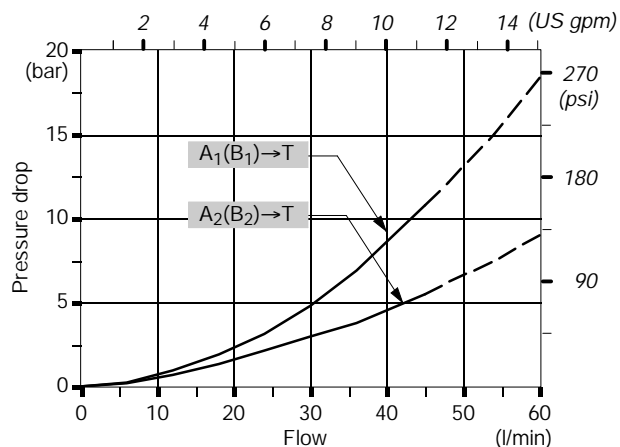
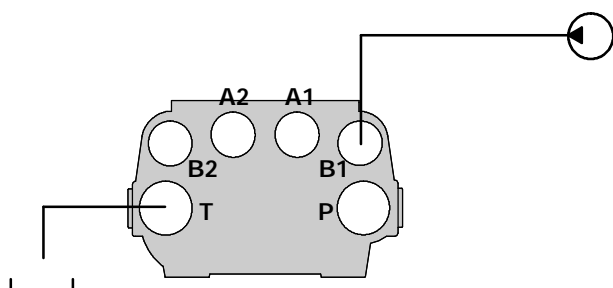

NOTE - Measured with spools type 1 and 5 (standard configuration)

Ordering codes

Description example:

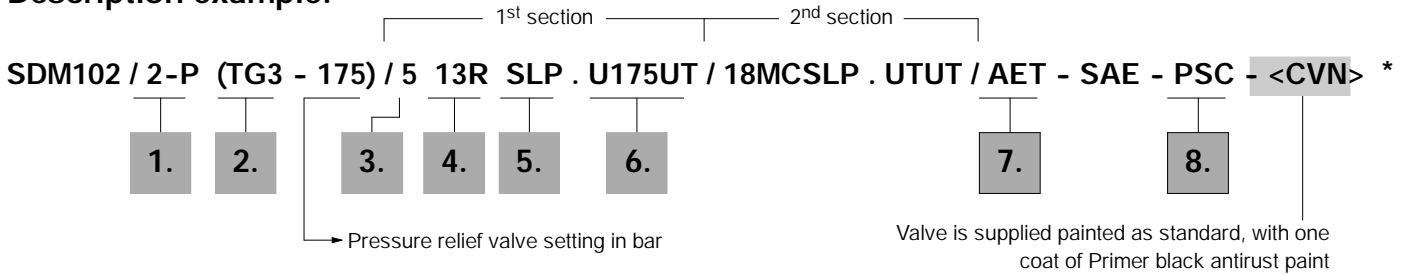

1. Body kit *

TYPE	CODE	DESCRIPTION
2-P	5KC1858000	2 section, without valve prearrangement
2-P	5KC1858001	2 section, with valve prearrangement on each section

Include body, seals, rings and load check valve.

2. Inlet relief options page 10

TYPE	CODE	DESCRIPTION
<u>VMD080 direct pressure relief valve type T</u>		
(TG2-80)	X162121080	Range 63 to 125 bar / 900 to 1800 psi standard setting 80 bar / 1150 psi
(TG3-175)	X162121175	Range 100 to 200 bar / 1450 to 2900 psi standard setting 175 bar / 2500 psi
(TG4-250)	X162121250	Range 160 to 250 bar / 2300 to 3600 psi standard setting 250 bar / 3600 psi

Standard setting is referred to 10 l/min - 2.6 US gpm flow.

SV	XTAP524340	Relief valve blanking plug
----	------------	----------------------------

3. Spool options page 11

TYPE	CODE	CIRCUIT DESCRIPTION
J 1	3CU5210100	Double acting, 3 positions, with A and B closed in neutral position
5	3CU5242100	Double acting, 4 positions, with A and B to tank in 4 th position (float)
F 8	3CU5262100	Double acting, 4 positions, with regenerative in 4 th position

4. "A" side spool positioners page 14

TYPE	CODE	DESCRIPTION
J 8MC	5V08205000	With spring return in neutral position
13R	5V13306010	With detent in position 3, spring return in neutral position
F 13F	5V13505100	With spring return in neutral position and reduced stroke

5. "B" side options page 15

TYPE	CODE	DESCRIPTION
SLP	5COP107000	Without lever, with dust-proof plate
LG	5LEV107805	Cast iron lever box
TQ	5TEL107100	Prearranged for cable remote control
LCB	5CLO202000	Mechanical joystick

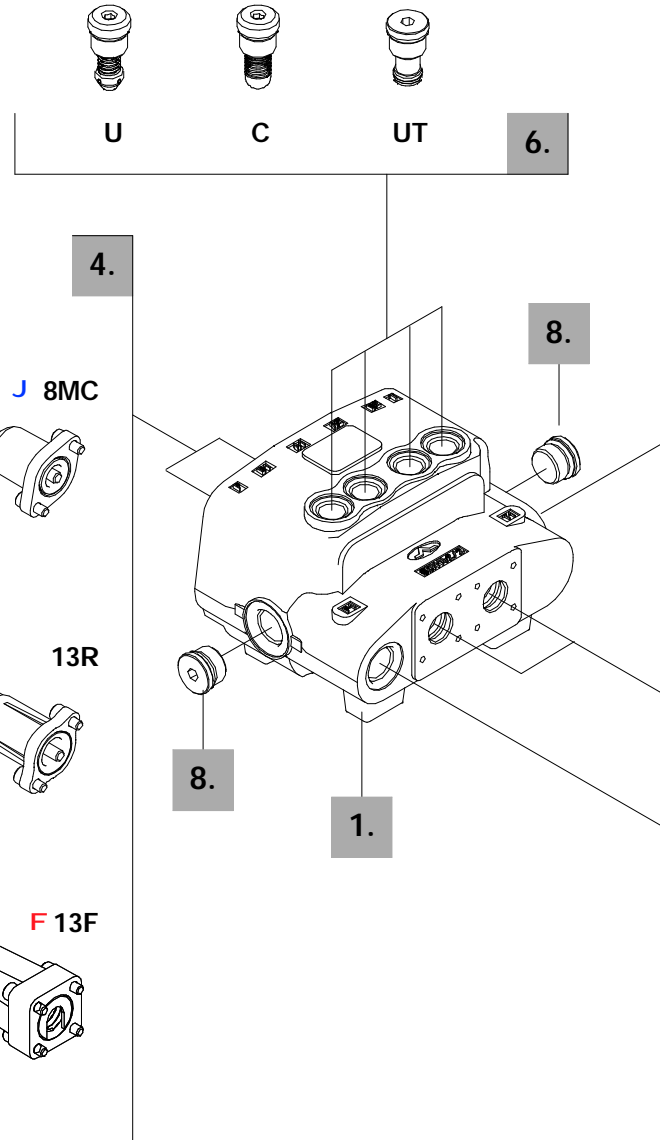

NOTE (*) - Items are referred to UN-UNF thread.

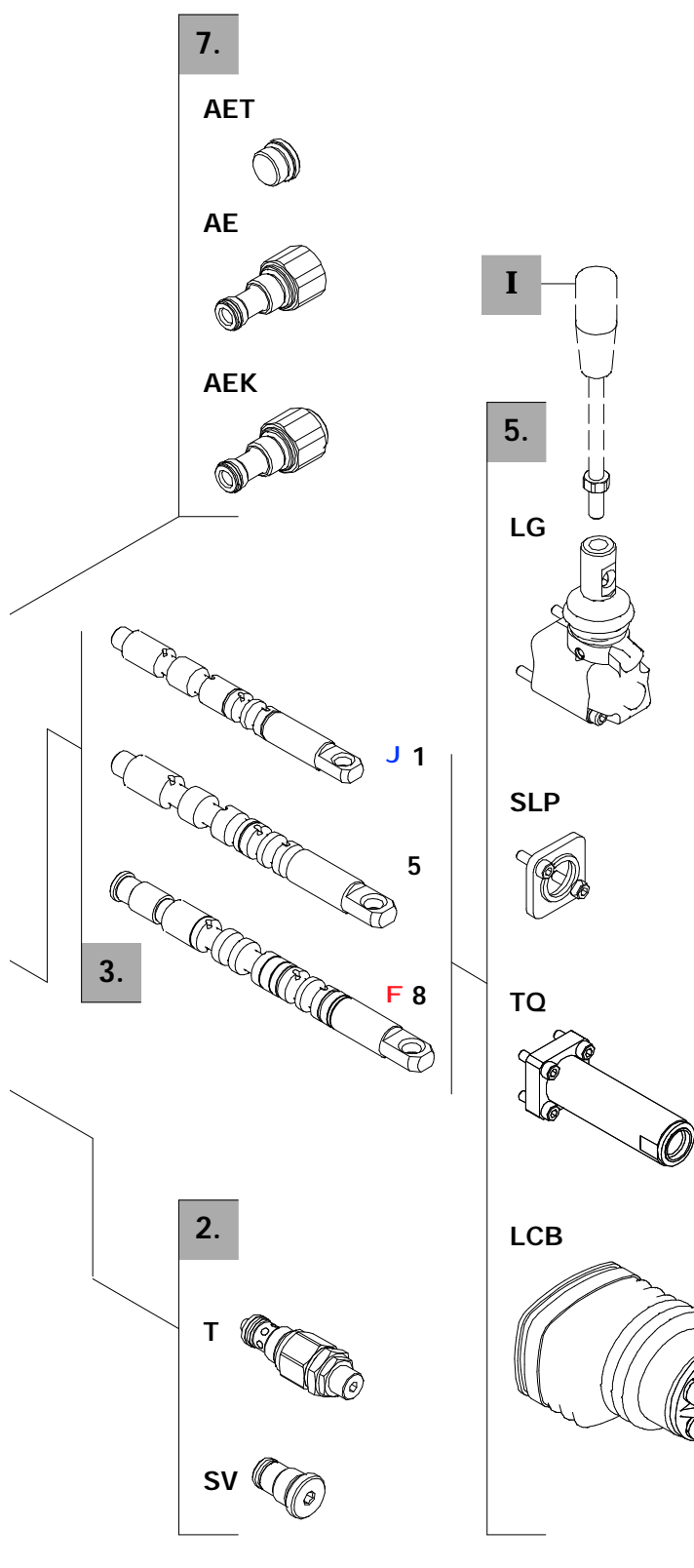

6. Port relief options page 18

TYPE	CODE	DESCRIPTION
<u>Anti-shock and anti-cavitation valves</u>		
U025	5KIT326025	Setting to 25 bar / 360 psi
U040	5KIT326040	Setting to 40 bar / 580 psi
U060	5KIT326060	Setting to 60 bar / 870 psi
U070	5KIT326070	Setting to 70 bar / 1000 psi
U080	5KIT326080	Setting to 80 bar / 1150 psi
U090	5KIT326090	Setting to 90 bar / 1300 psi
U100	5KIT326100	Setting to 100 bar / 1450 psi
U125	5KIT326125	Setting to 125 bar / 1800 psi
U140	5KIT326140	Setting to 140 bar / 2030 psi
U160	5KIT326160	Setting to 160 bar / 2300 psi
U175	5KIT326175	Setting to 175 bar / 2500 psi
U190	5KIT326190	Setting to 190 bar / 2750 psi
U210	5KIT326210	Setting to 210 bar / 3050 psi
U230	5KIT326230	Setting to 230 bar / 3300 psi
U250	5KIT326250	Setting to 250 bar / 3600 psi
U260	5KIT326260	Setting to 260 bar / 3750 psi
U280	5KIT326280	Setting to 280 bar / 4000 psi

Standard setting is referred to 10 l/min - 2.6 US gpm flow.

C	5KIT426270	Anti-cavitation valve
UT	XTAP221340	A and B port valve blanking plug

7. Outlet conversion port options * page 20

TYPE	CODE	DESCRIPTION
AET	3XTAP822150	Open center (nr.1 SAE 8 plug required)
AE	XGIU527580	SAE 8 power beyond sleeve
AEK	5GIU527580	Closed center kit

8. Inlet and outlet plugs *

TYPE	CODE	DESCRIPTION
PSC	3XTAP822150	Cap side inlet and outlet (SAE 8 nr.2 plugs required)
PSL	3XTAP822150	Side inlet and outlet (SAE 8 nr.2 plugs required)

I Optional hand levers

TYPE	CODE	DESCRIPTION
AL01/M10x150	170012015	For LG lever box L = 150 mm / 5.91 in
AL08/M12x200	170013120	For LCB joystick L = 200 mm / 7.87 in

NOTE J F - Spools and positioners with the same symbol must be assembled together: for more informations see relevant pages.

Inlet relief options

Pressure relief valve

VMD080 (T G 3 - 175)

- Pressure setting in bar (standard 175 bar - 2540 psi).
- Adjustable spring type (2, 3, 4).
- Adjustment type (G, Z).

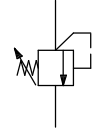

Adjustment type

G: with screw

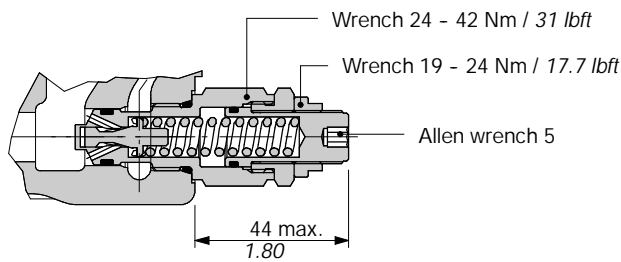

Z: with tamper proof cap

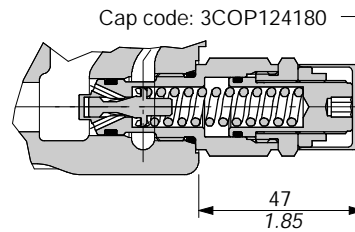

Performance data

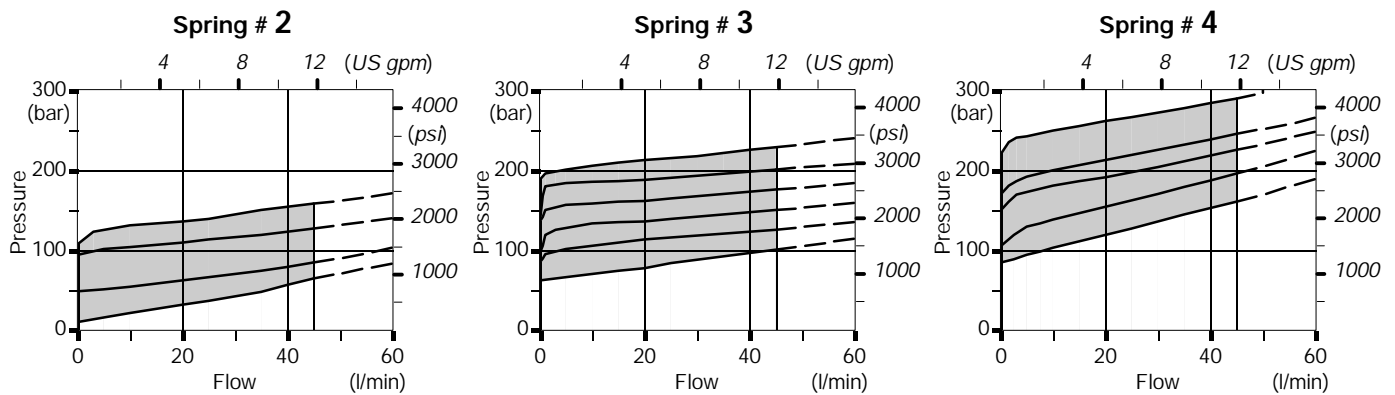

SV: relief valve blanking plug

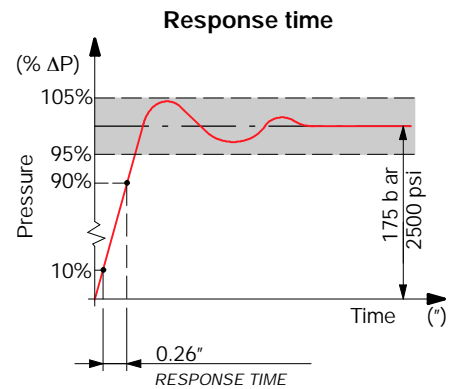
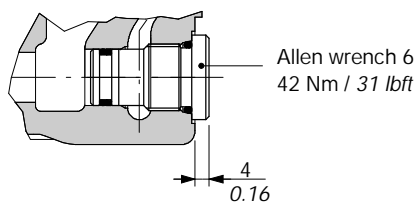

Type 1

Must be used only on 2nd section valve with positioner kit type 8MC .

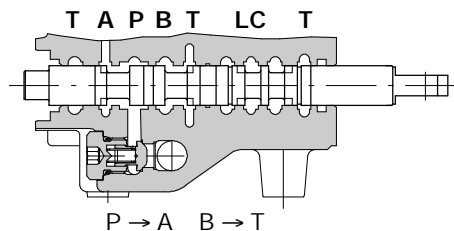

stroke = + 5.5 mm
+ 0.22 in

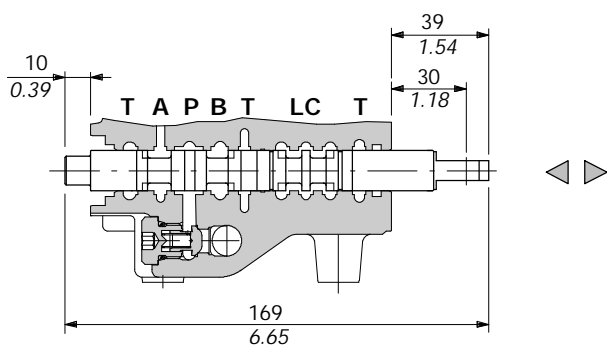
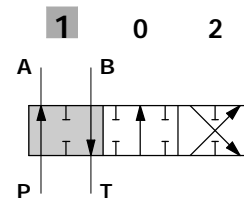

P-A-B-T closed, with flow through line (LC) open

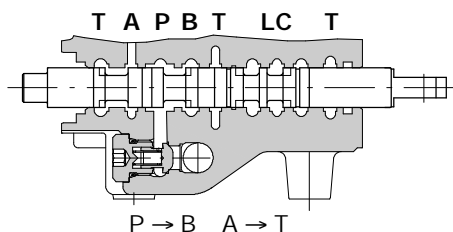
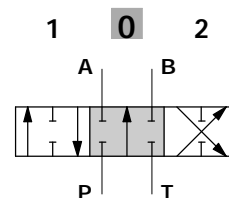

stroke = - 5.5 mm
- 0.22 in

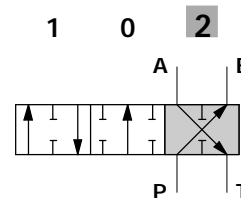

Performance data

Spool metering P→A(B)

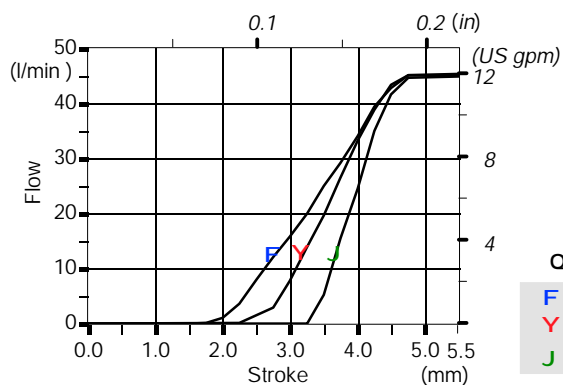

Q_{in} = 45 l/min - 12 US gpm

- F P(on ports) = 63bar/900psi
- Y P(on ports) = 100bar/1450psi
- J P(on ports) = 250bar/3600psi

Spool metering A(B)→T

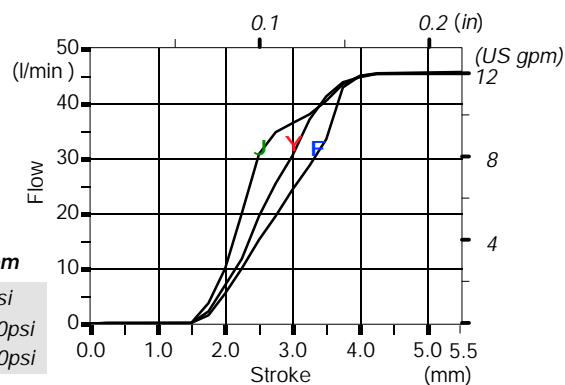

Spools

Type 5

Must be used only on 1st section valve with positioner kit type 8MC or 13R.

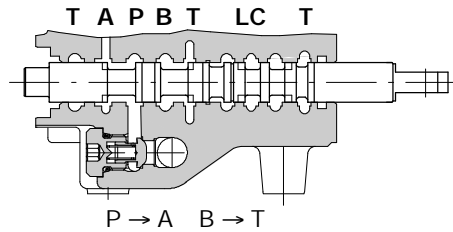

stroke = + 5.5 mm
+ 0.22 in

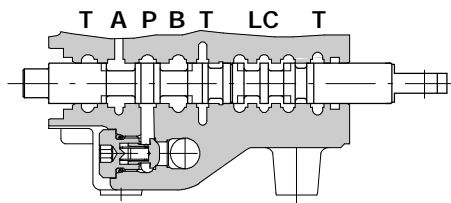
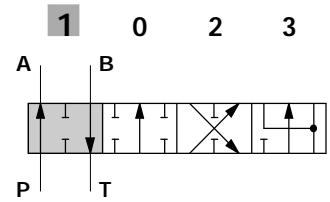

A stroke = - 5.5 mm
- 0.22 in

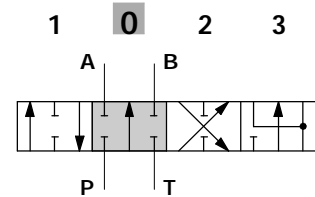

P-A-B-T closed, with flow through line (LC) open

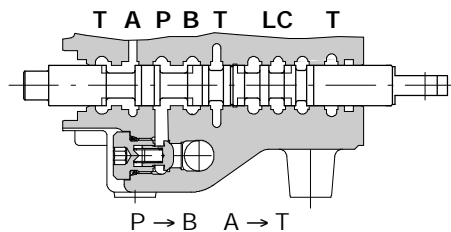

A A stroke = - 10 mm
- 0.39 in

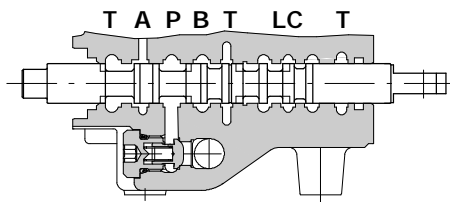
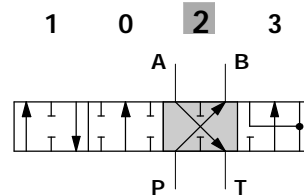

Float only with 13R positioner kit

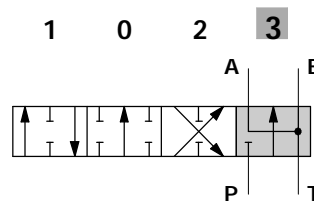

NOTE - **A A** Only for positioner kit type 13R.

Performance data

Spool metering P → A(B)

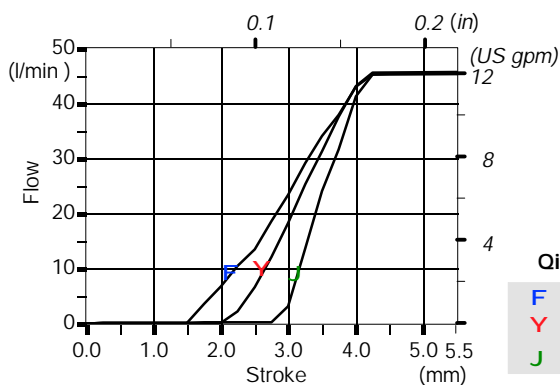

Spool metering A(B) → T

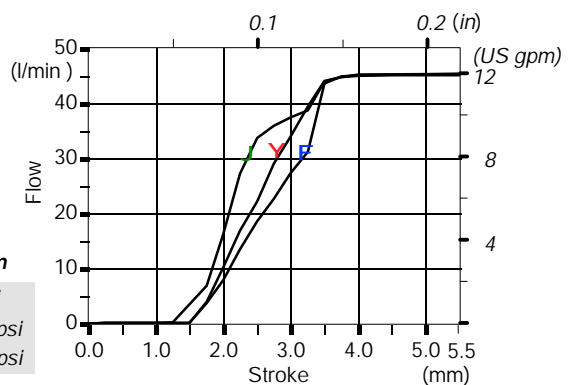

Type 8

Must be used only in 2nd section valve with positioner kit type 13F.

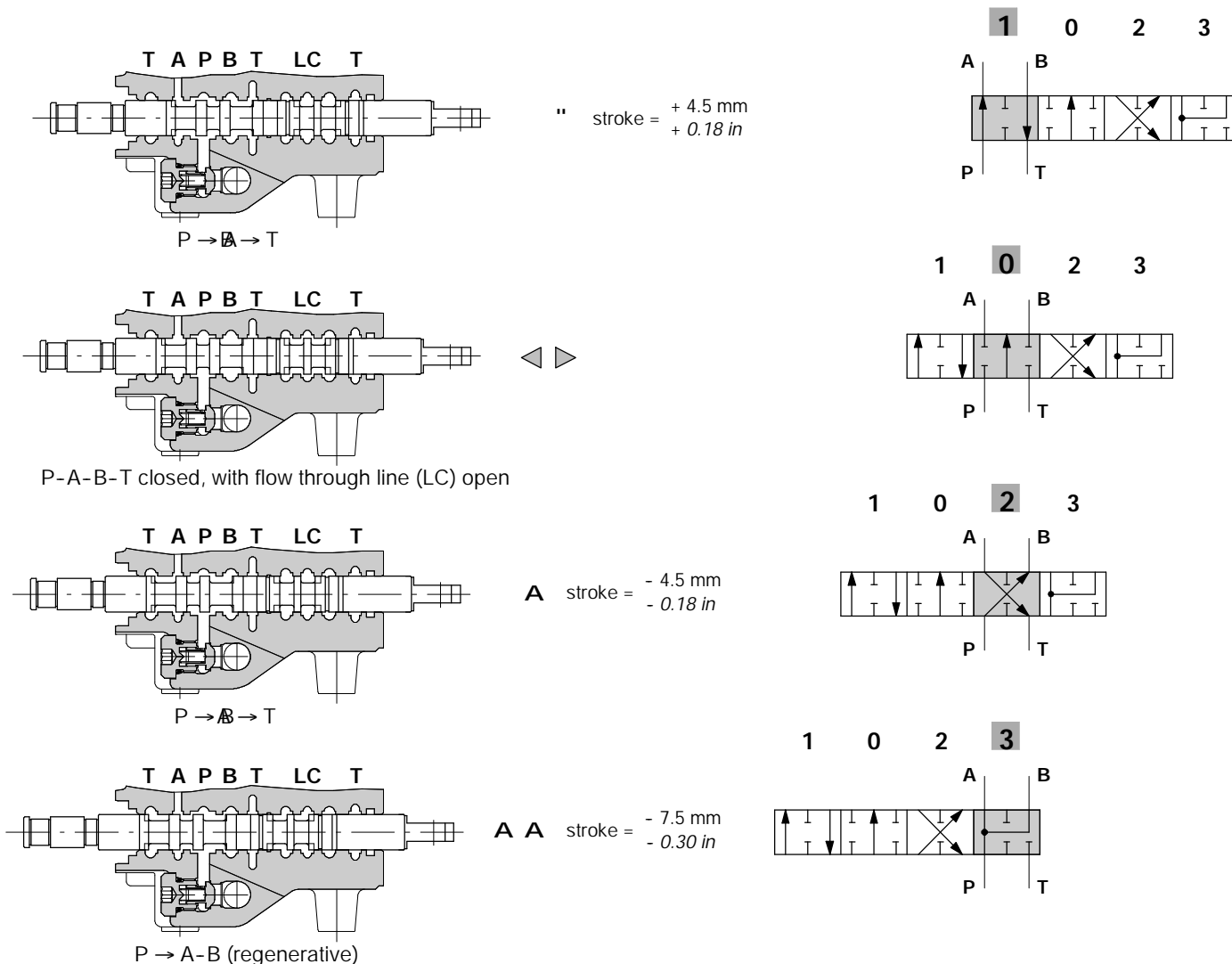

Performance data

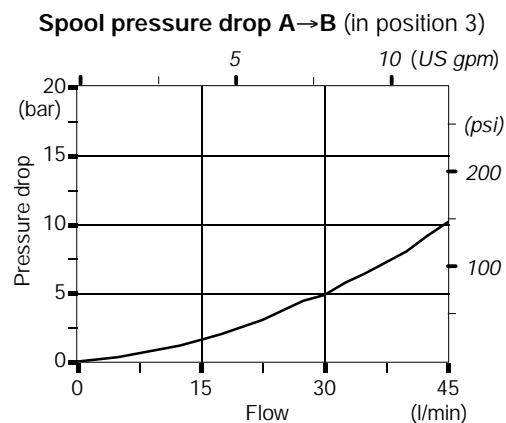
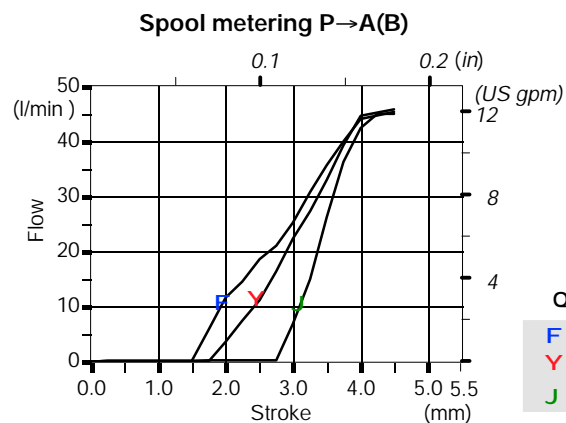

"A" side spool positioners

With spring return

8MC kit

Supplied with standard spring type C (see force-stroke diagram); available with lighter spring type B (**8MB** code: 5V08505000) or heavier type D (**8** code: 5V08105000).

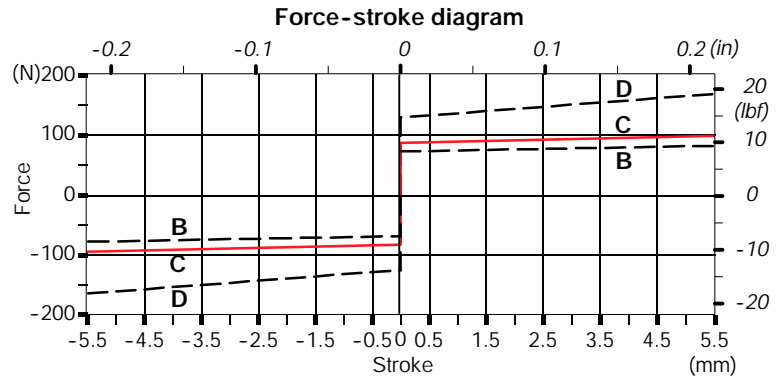
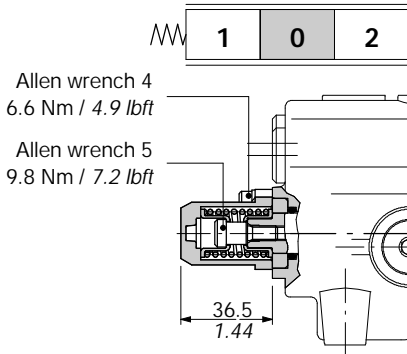

With spring return - 4th position regenerative circuit

13F kit

Must be used with spool type 8 (page 13).

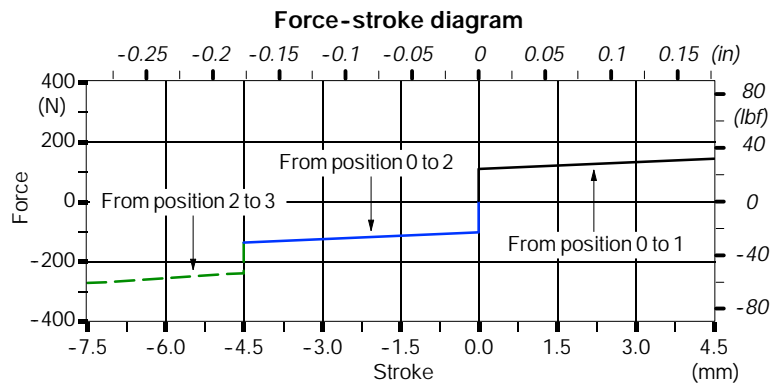
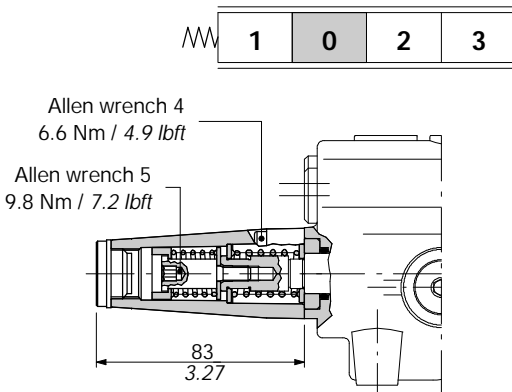

With detent on 4th position float circuit

13R kit

Must be used with spool type 5 (page 12).

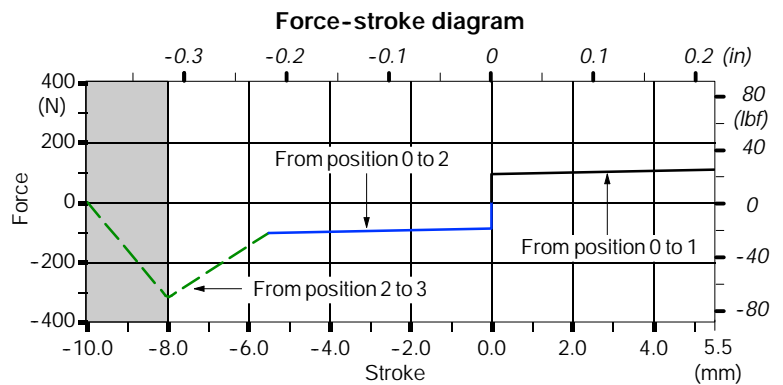
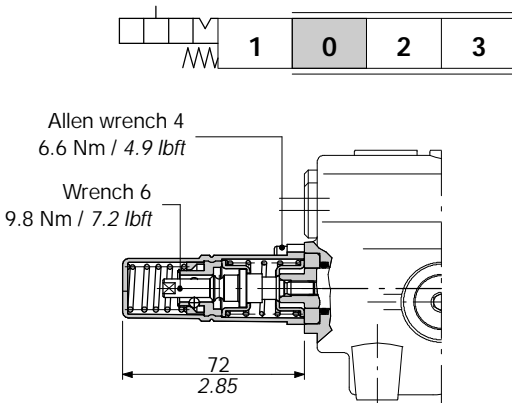

Locking-unlocking area
 Locking force: 320 N / 71.9 lbf ±10%
 Unlocking force: 315 N / 70.8 lbf ±10%

SLP dust proof plate

Mechanical control with dust proof plate

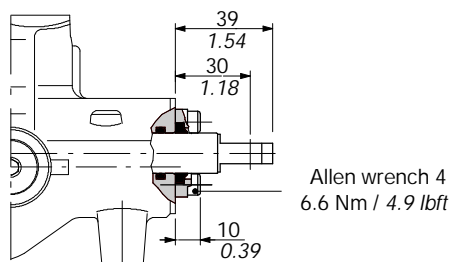
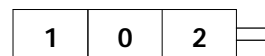

Spool dimension

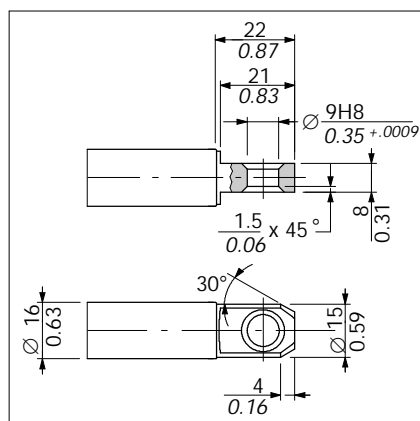

LG cast iron lever box

With protection boot lever pivot box; it can be rotated 180° (LG180 configuration).

Also available alluminium lever box: L configuration, code 5LEV107900

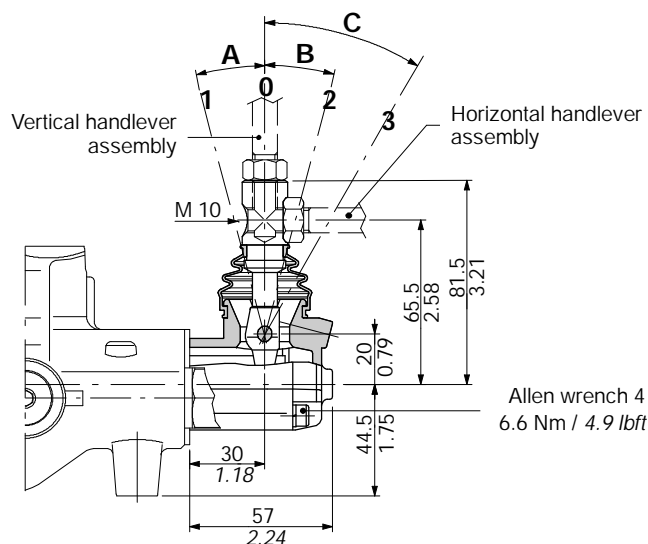
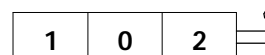

LG180 configuration

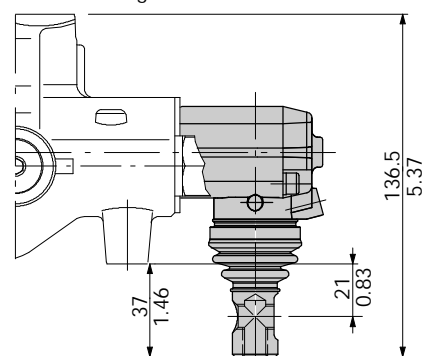

Lever angle	Spool type		
	1	5	8
A	15°	15°	13°
B	15°	15°	13°
C	/	27°	21°

NOTE - The handlever must be ordered separately (see page 9).

SDM102

"B" side options

TQ cable remote control

Waterproof cap for remote control with flexible cable.

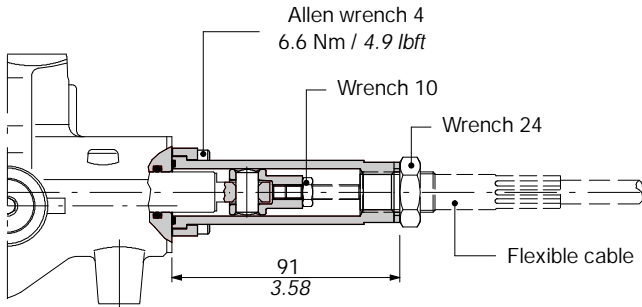
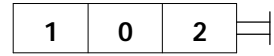

Example of cable control

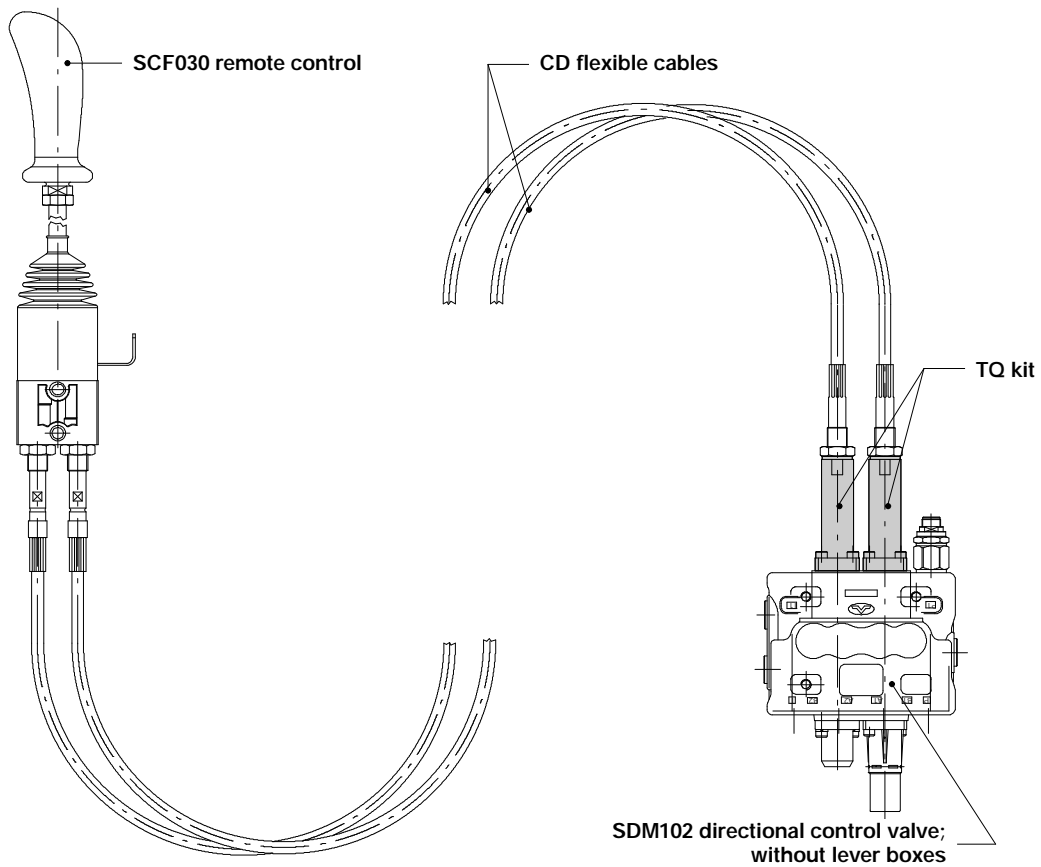

NOTE - For more information concerning remote cable control require appropriate documentation.

Mechanical joystick LCB

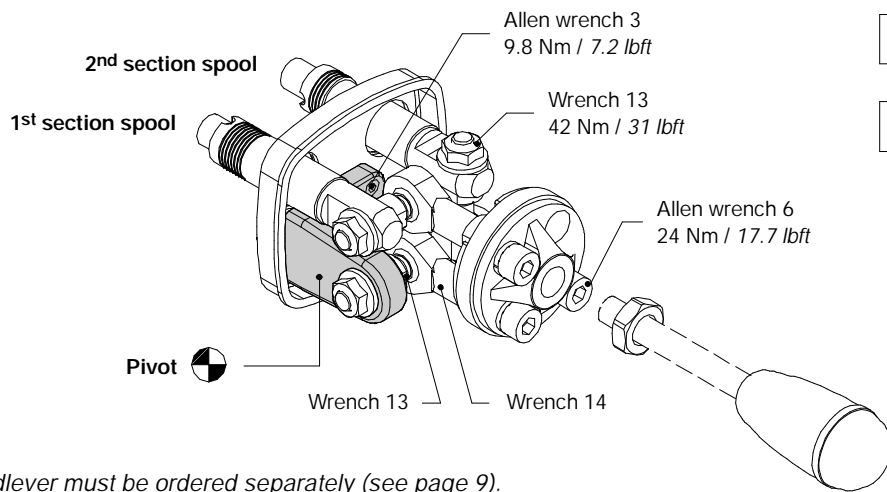

NOTE - The handlever must be ordered separately (see page 9).

Dimensions and movement scheme

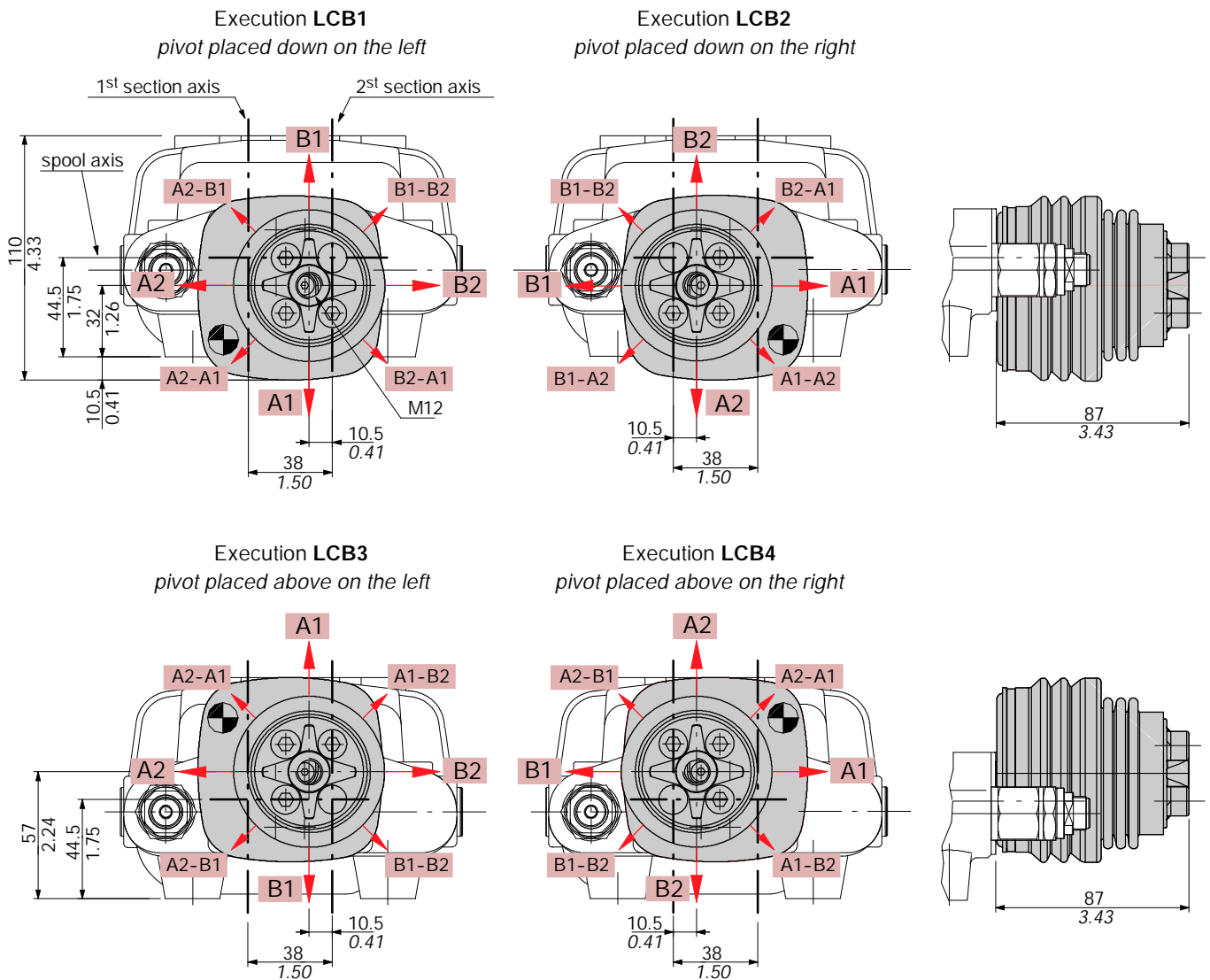

SDM102

Port relief options

Available on prearranged body.

Anti-shock and anti-cavitation valve

U 175

Pressure setting in bar

Wrench 5
24 Nm / 17.7 lbf

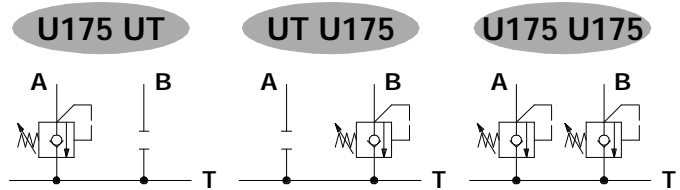
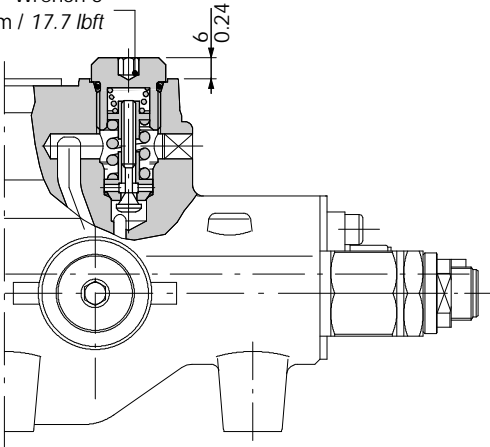

Performance data

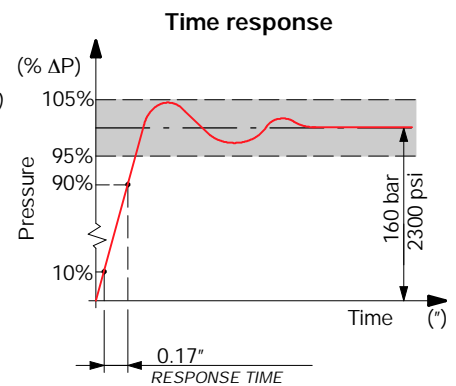
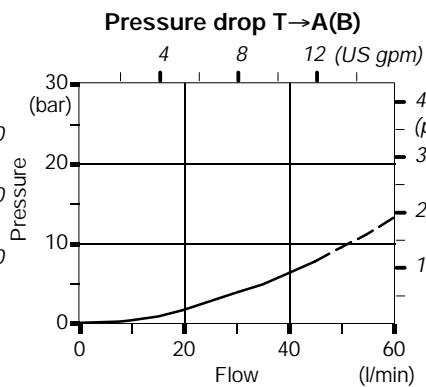
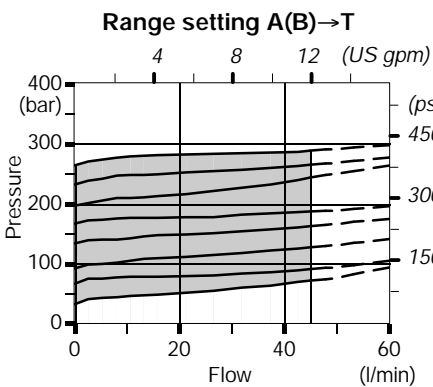

Available on prearranged body.

Anti-cavitation valve

C

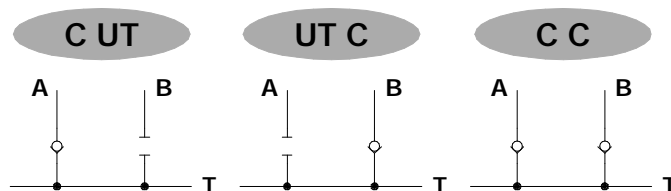
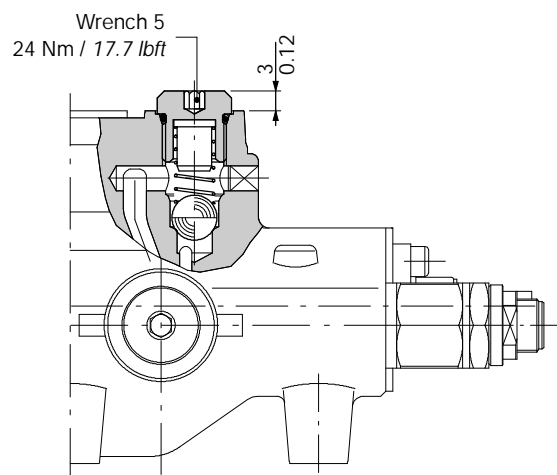

Performance data

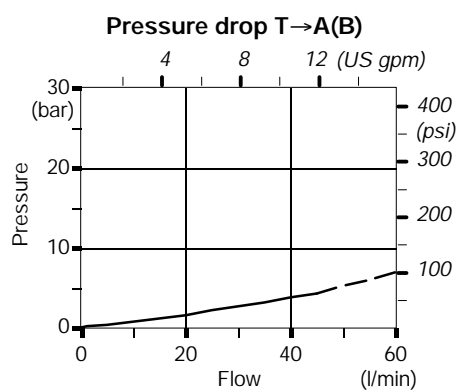

Port relief valve blanking plug

UT

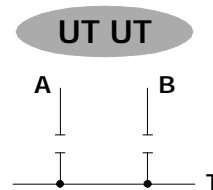
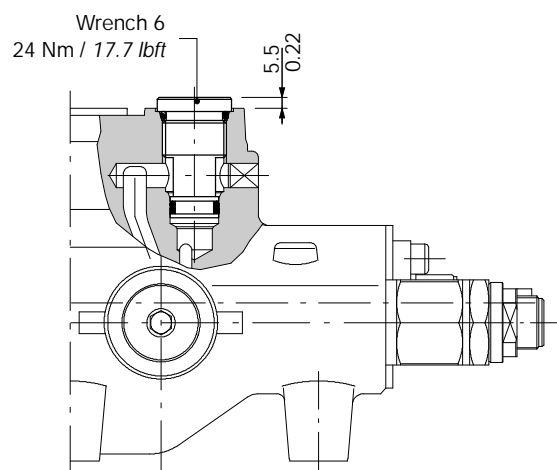

Outlet conversion port options

AE: with power beyond

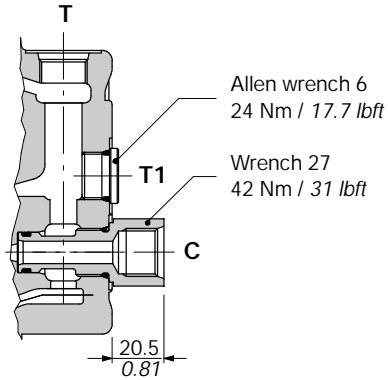

Ex.: SDM102/2-P(TG3-175)/513RSLP/18MCSLP/AE-PSC-<CVN>

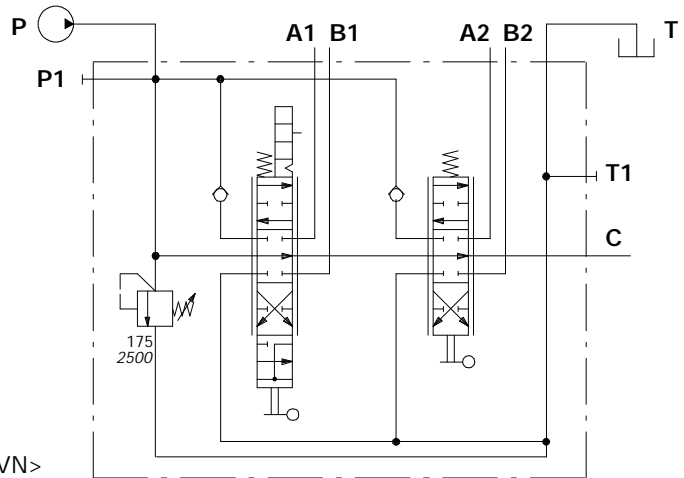

AEK: with closed center

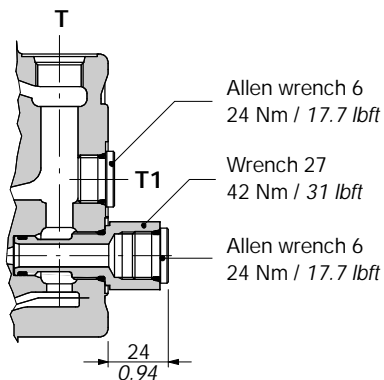

Ex.: SDM102/2-P(TG3-175)/513RSLP/18MCSLP/AEK-PSC-<CVN>

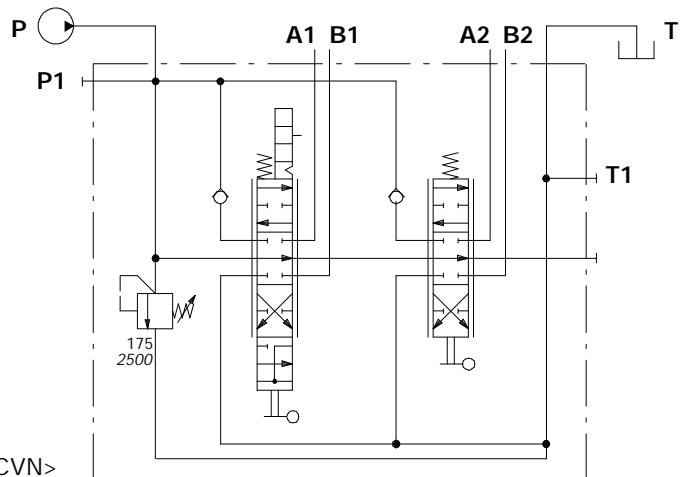

KAE: with full system pressure power beyond

This option requires special valve body kit; contact Customer Service for more information.

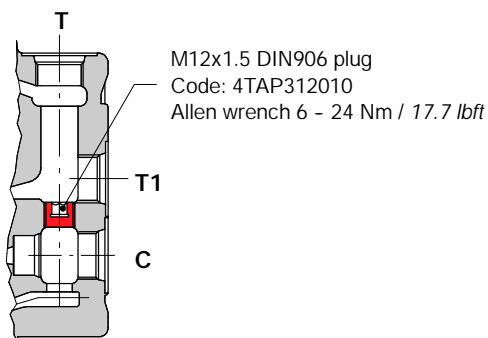

Ex.: SDM102/2-P(TG3-175)/513RSLP/18MCSLP/KAE-PSC-<CVN>

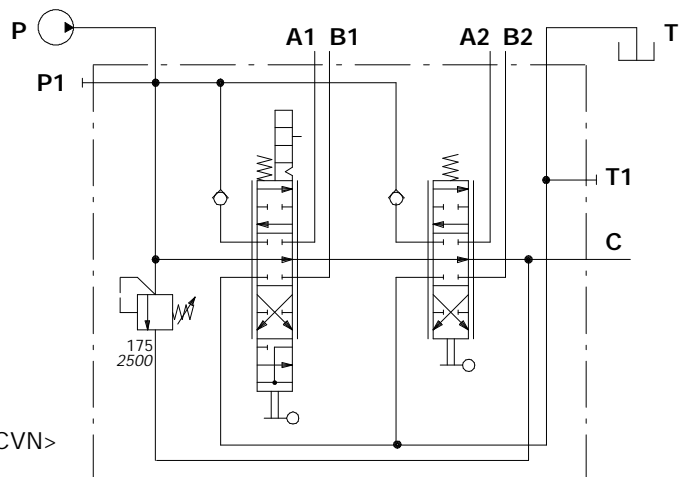

The SDM102 valve is assembled and tested as per the technical specification of this catalog.

Before the final installation on your equipment, follow the below recommendations:

- the valve can be assembled in any position; in order to prevent body deformation and spool sticking mount the product on a flat surface;
- in order to prevent the possibility of water entering the spool control kit, do not use high pressure wash down directly on the valve;
- prior to painting, ensure plastic port plugs are tightly in place.

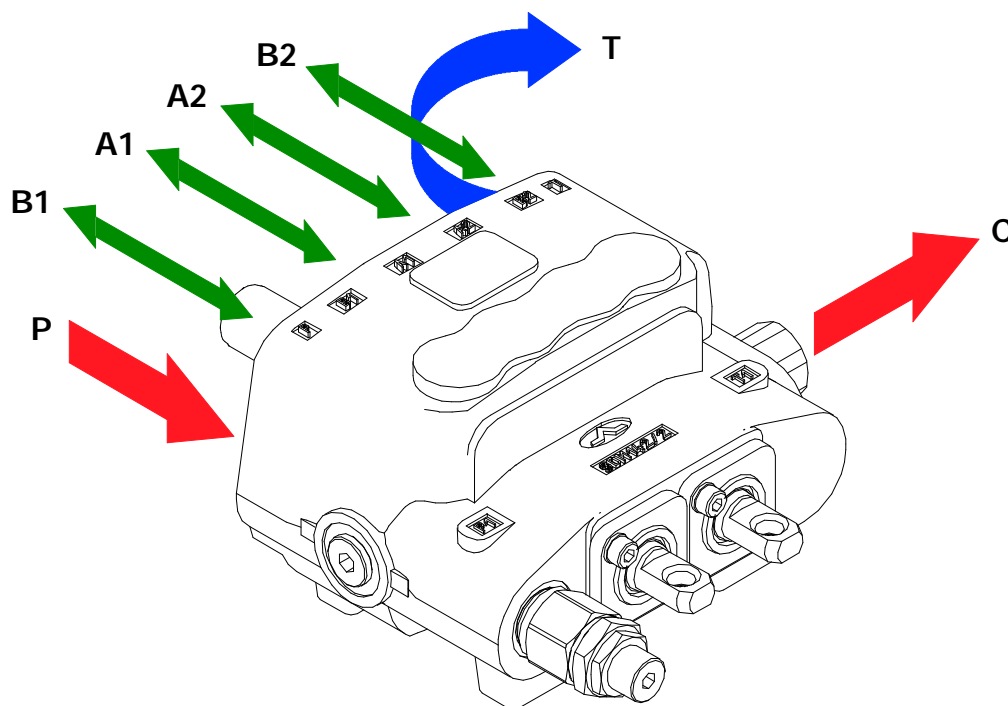

Power beyond configuration

Fitting tightening torque - Nm / lbft

THREAD TYPE	P and C ports	A and B ports	T port
BSP (ISO 228/1)	G 3/8	G 3/8	G 3/8
With O-Ring seal	35 / 25.8	35 / 25.8	35 / 25.8
With copper washer	40 / 29.5	40 / 29.5	40 / 29.5
With steel and rubber washer	30 / 22.1	30 / 22.1	30 / 22.1
UN-UNF (ISO 11926-1)	3/4-16 UNF-2B (SAE 8)	9/16-18 UNF-2B (SAE 6)	3/4-16 UNF-2B (SAE 8)
With o-ring seal	50 / 36.9	30 / 22.1	50 / 36.9
METRIC (ISO 262)	M18 x 1.5	M18 x 1.5	M18 x 1.5
With O-Ring seal	35 / 25.8	35 / 25.8	35 / 25.8
With copper washer	40 / 29.5	40 / 29.5	40 / 29.5
With steel and rubber washer	40 / 29.5	40 / 29.5	40 / 29.5

NOTE - These torque are recommended. Assembly tightening torque depends on many factors, including lubrication, coating and surface finish. The manufacturer shall be consulted.

Installation and maintenance

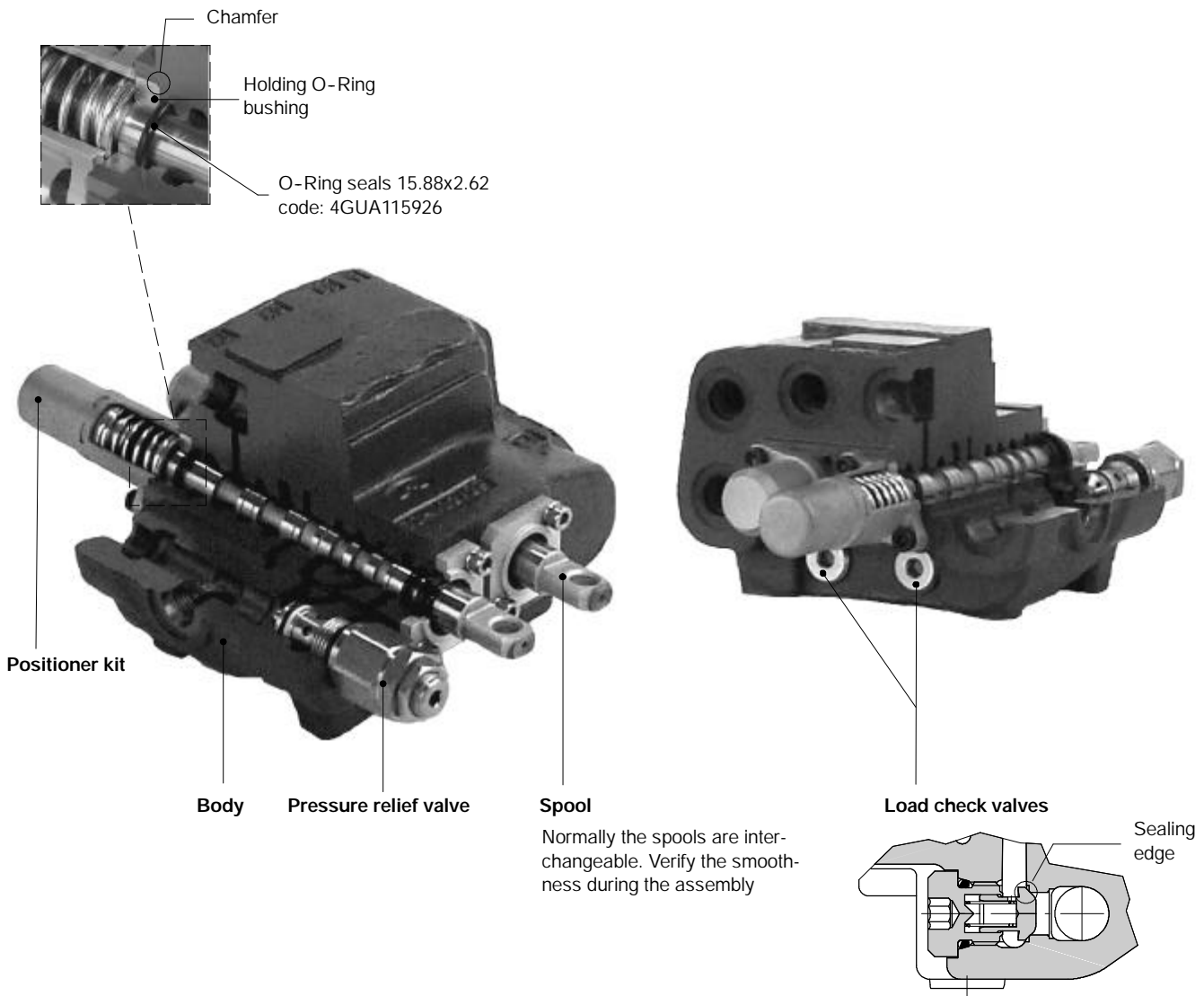

NOTE - All articulated parts inside cap, lever box and mechanical joystick are lubricated with synthetic base grease grade NLGI2

Malfunction	Cause	Remedy
External leakage control kit or opposite side.	Worn spool seal due to mechanical actuation or high back pressure.	Locate the leakage and replace the seal. Check back pressure level.
Excessive internal leakage on A and B ports.	Increase clearance between spools and body due to high wear	Replace the directional control valve and check the oil contamination level.
Dropping load during transition while raising	High leakage on the load check valve.	Remove the load check valve and clean the seat.
Inability to build pressure on A and B ports.	Main pressure relief valve blocked open.	Remove and clean or replace the main relief valve.
	Port relief valve open.	Remove and clean or replace the port relief valve.
	Low pump pressure and flow.	Check the pump and circuit.



WALVOIL S.P.A.

42100 REGGIO EMILIA • ITALY • VIA ADIGE, 13/D
TEL. +39.0522.932411 • FAX +39.0522.300984
E-MAIL: INFO@WALVOIL.COM • HTTP: //WWW.WALVOIL.COM

SALES DEPARTMENT

TEL. +39.0522.932555 • FAX +39.0522.932455

DAT011A