



ER..M type directional solenoid valve - 4 way / 2 positions

- Direct acting
- Spool type
- From SAE08 to SAE12 cavities

Technical specifications and diagrams are measured with mineral oil of 46 cSt viscosity at 40°C (104°F) temperature.

	ER08M	ER10M	ER12M
Nominal flow	20 l/min (5.3 US gpm)	40 l/min (10.5 US gpm)	60 l/min (15.8 US gpm)
Max. pressure	port 1	210 bar (3050 psi)	250 bar (3600 psi)
	port 2,3,4	210 bar (3050 psi)	320 bar (4600 psi)
Oil leakage	at 210 bar (3050 psi) 40 cm ³ /min (2.44 in ³ /min)	80 cm ³ /min (4.88 in ³ /min)	200 cm ³ /min (12.20 in ³ /min)
Fluid	mineral based oil		
Viscosity	10-200 cSt		
Max level of contamination	18/16/13 ISO4406		
Fluid temperature	with NBR seals	from -20°C (-4°F) to 80°C (176°F)	
	with FPM seals	from -20°C (-4°F) to 100°C (212°F)	
Environmental temp. for working conditions	from -20°C (-4°F) to 50°C (122°F)		
Cavity	SAE 08/4	SAE 10/4	SAE 12/4
Coils type*	BER	BC	BH
Nominal voltages	12 VDC - 24 VDC ± 10%	12 VDC - 24 VDC ± 10%	12 VDC - 24 VDC ± 10%
Power rating	22.8 W (12 VDC)	26.1 W (12 VDC)	33 W (12/24 VDC)
	22.5 W (24 VDC)	25.9 W (24 VDC)	
Weight	0.20 kg (0.44 lb)	0.50 kg (1.10 lb)	0.73 kg (1.61 lb)

NOTE - For different conditions, please contact Walvoil Sales Dpt. - *For coils further features see from page 206.

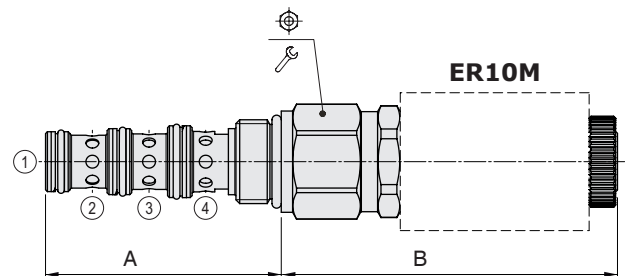
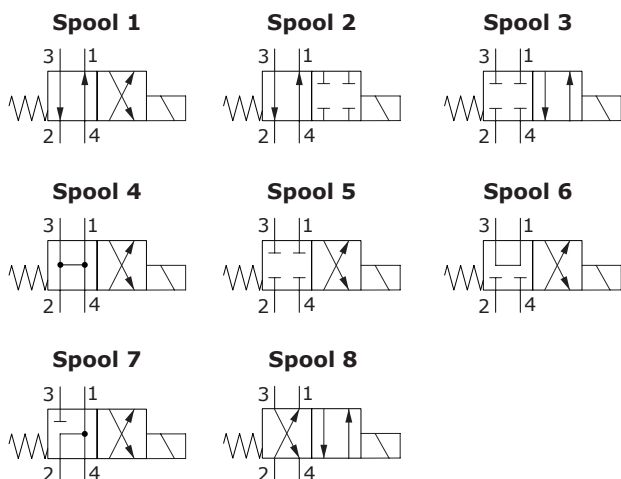

Valve type	A		B		⊕	⌘	Nm	lbf·ft
	mm	in	mm	in				
ER08M/..NB	53.6	2.11	75	2.95	24	30	22	
ER10M/..NB	62.4	2.46	89	3.50	27	50	37	
ER12M/..NB	81.4	3.20	85.5	3.37	32	85	63	

For dimensions with different type of emergency see page 213

Ordering codes and description composition

ER08M/10 NB

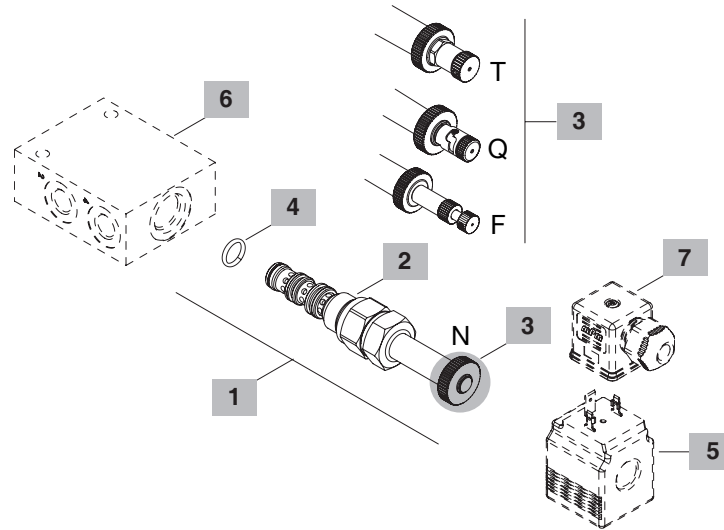
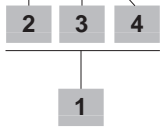

1 Cartridges

TYPE	CODE	DESCRIPTION
SAE cavity 08/4		
ER08M/10NB	0ER08002016	Without emergency, spool 1
ER08M/20NB	0ER08002017	Without emergency, spool 2
ER08M/30NB	0ER08002018	Without emergency, spool 3
ER08M/40NB	0ER08002019	Without emergency, spool 4
ER08M/50NB	0ER08002020	Without emergency, spool 5
ER08M/60NB	0ER08002021	Without emergency, spool 6
ER08M/70NB	0ER08002022	Without emergency, spool 7
ER08M/80NB	0ER08002023	Without emergency, spool 8
SAE cavity 10/4		
ER10M/10NB	0ER10002023	Without emergency, spool 1
ER10M/20NB	0ER10002024	Without emergency, spool 2
ER10M/30NB	0ER10002025	Without emergency, spool 3
ER10M/40NB	0ER10002026	Without emergency, spool 4
ER10M/50NB	0ER10002027	Without emergency, spool 5
ER10M/60NB	0ER10002028	Without emergency, spool 6
ER10M/70NB	0ER10002029	Without emergency, spool 7
ER10M/80NB	0ER10002030	Without emergency, spool 8
SAE cavity 12/4		
ER12M/10NB	0ER12002021	Without emergency, spool 1
ER12M/20NB	0ER12002023	Without emergency, spool 2
ER12M/50NB	0ER12002024	Without emergency, spool 5
ER12M/80NB	0ER12002022	Without emergency, spool 8

2 Spool

TYPE	DESCRIPTION
1	Spool 1
2	Spool 2
3	Spool 3
4	Spool 4
5	Spool 5
6	Spool 6
7	Spool 7
8	Spool 8

3 Emergency

TYPE	DESCRIPTION
N	Without emergency
F	Pull button type
Q	Pull type with detent
T	Screw type

4 Seals

TYPE	DESCRIPTION
B	NBR (Buna) o-ring seals, std configuration (*)
V	FPM (Viton) o-ring seals, contact Sales Dept.

Note (*): for ER12M, NBR and polyurethane D-ring

5 Coils

TYPE	CODE	DESCRIPTION
BER 12VDC-ISO4400	4SLE001200	12VDC-ISO4400 coil for ER08M
BC 12VDC-ISO4400	4SL8000120	12VDC-ISO4400 coil for ER10M
BH 12VDC-ISO4400	4SLD001200	12VDC-ISO4400 coil for ER12M

For complete coils list see from page 206

6 Valve body

TYPE	CODE	DESCRIPTION
SAE 08/4-G 3/8	3CC0840C11	Aluminium body for cavity 08 valve, G3/8 std thread
SAE 10/4-G 3/8	3CC1020C11	Aluminium body for cavity 10 valve, G3/8 std thread
SAE 12/4-G 1/2	3CC1240D11	Aluminium body for cavity 12 valve, G1/2 thread

Note: aluminium body can stand up to 210 bar (3050 psi)
For steel bodies or different threading see from page 219

7 Connector

TYPE	CODE	DESCRIPTION
ISO4400	4CN1009995	Connector

For complete connectors list see from page 206

Directional control valves

Directional solenoid valves - 4 way / 2 positions

ER..M type

Rating diagrams

ER08M pressure drop vs. flow
- Spool 1 -

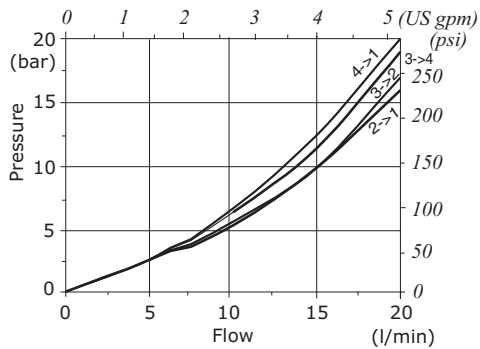

ER08M pressure drop vs. flow
- Spool 2 -

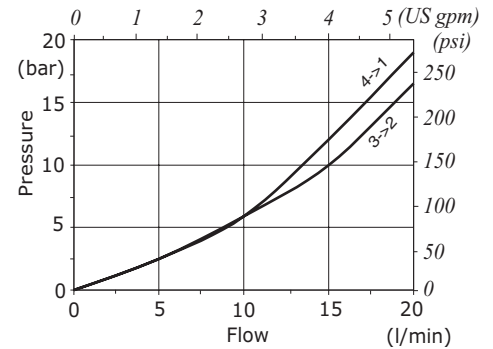

ER08M pressure drop vs. flow
- Spool 3 -

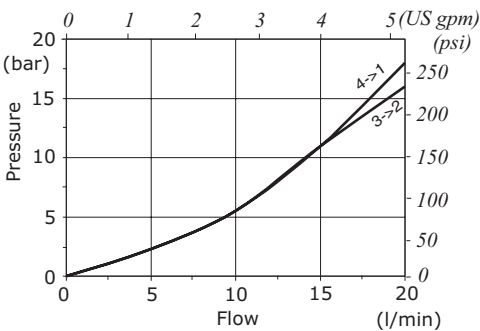

ER08M pressure drop vs. flow
- Spool 4 -

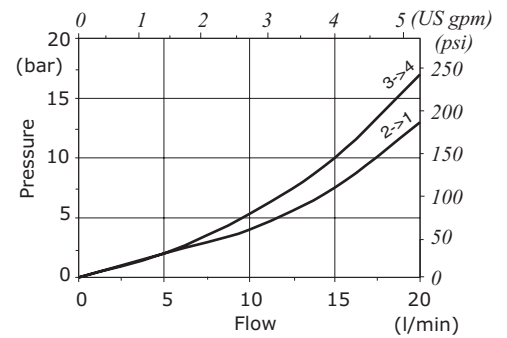

ER08M pressure drop vs. flow
- Spool 5 -

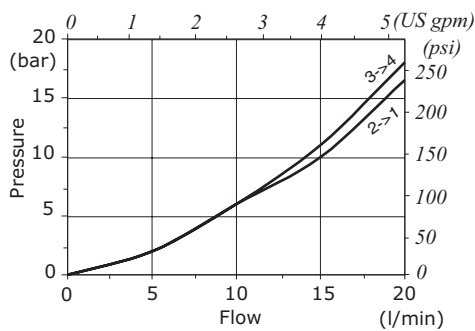

ER08M pressure drop vs. flow
- Spool 6 -

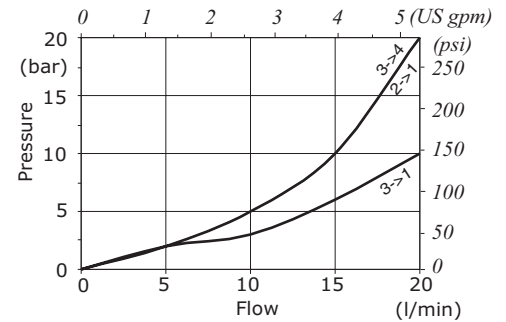

ER08M pressure drop vs. flow
- Spool 7 -

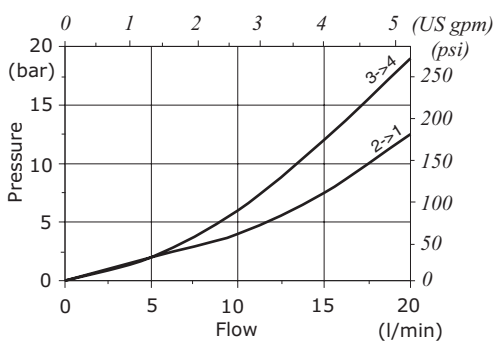

ER08M performance limit

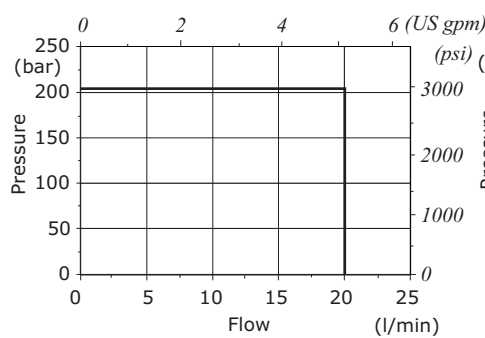

ER08M pressure drop vs. flow
- Spool 8 -

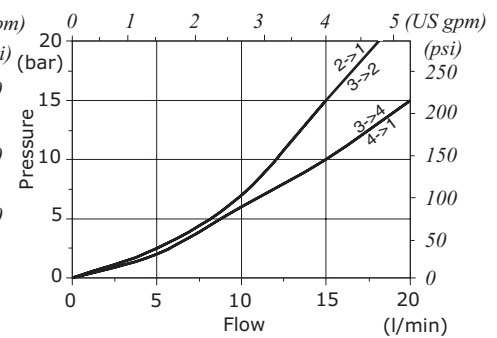

Rating diagrams

ER10M pressure drop vs. flow
- Spool 1 -

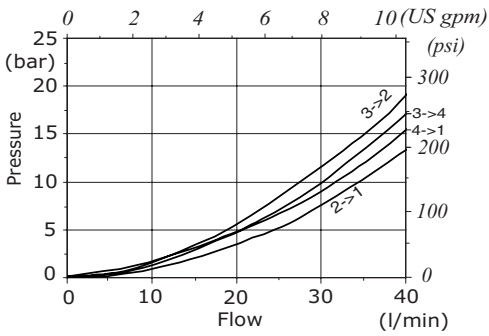

ER10M pressure drop vs. flow
- Spool 2 -

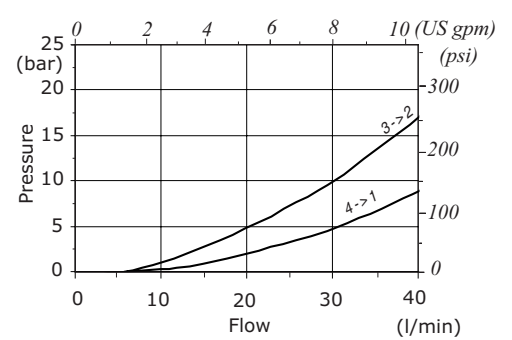

ER10M pressure drop vs. flow
- Spool 3 -

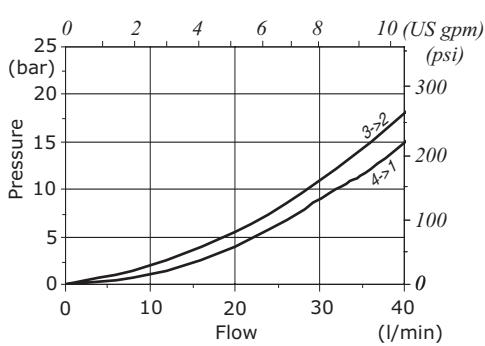

ER10M pressure drop vs. flow
- Spool 4 -

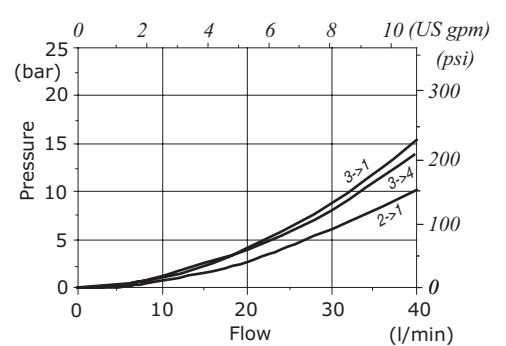

ER10M pressure drop vs. flow
- Spool 5 -

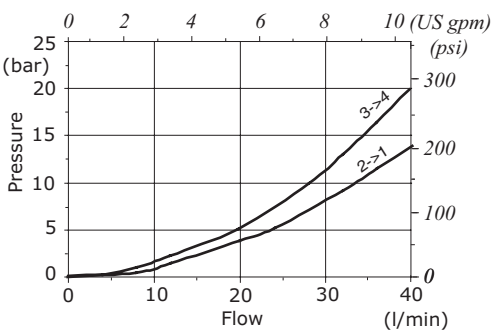

ER10M pressure drop vs. flow
- Spool 6 -

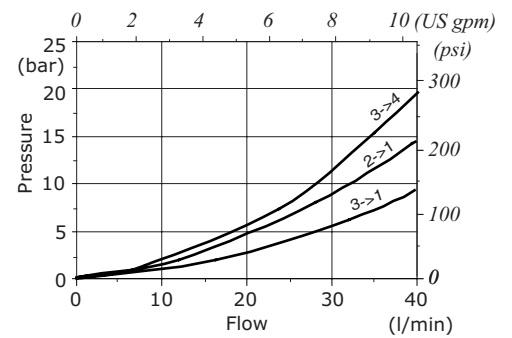

ER10M pressure drop vs. flow
- Spool 7 -

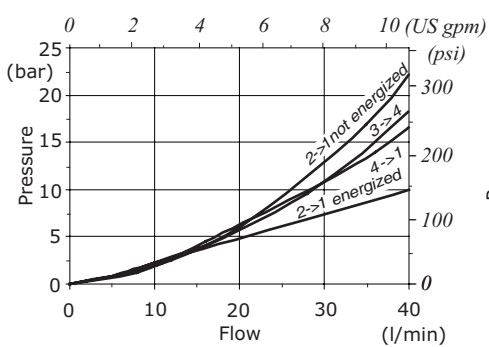

ER10M performance limit

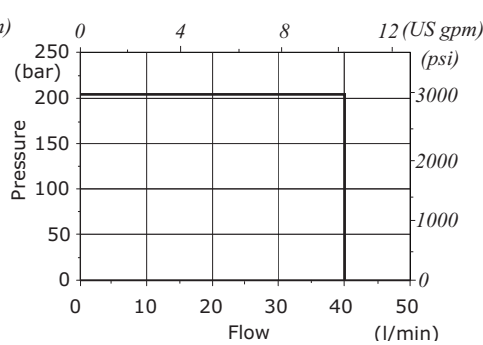

ER10M pressure drop vs. flow
- Spool 8 -

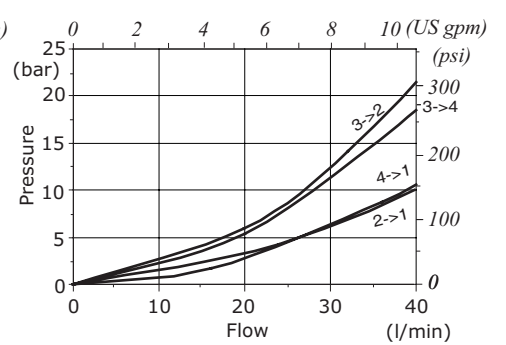

Directional control valves

Directional solenoid valves - 4 way / 2 positions

ER..M type

Rating diagrams

ER12M pressure drop vs. flow
- Spool 1 -

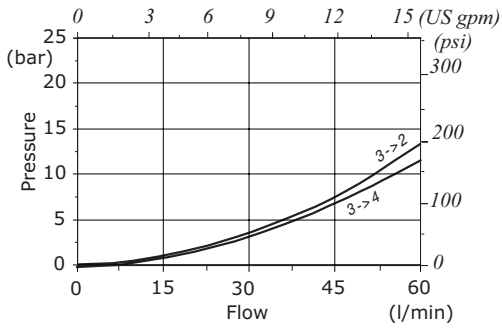

ER12M pressure drop vs. flow
- Spool 2 -

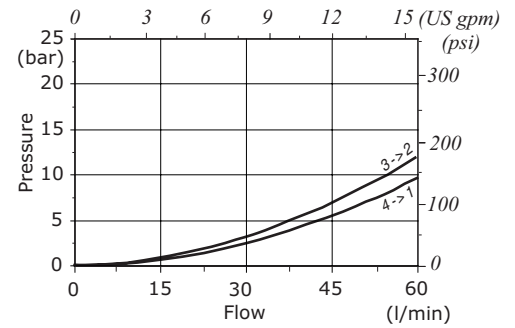

ER12M pressure drop vs. flow
- Spool 5 -

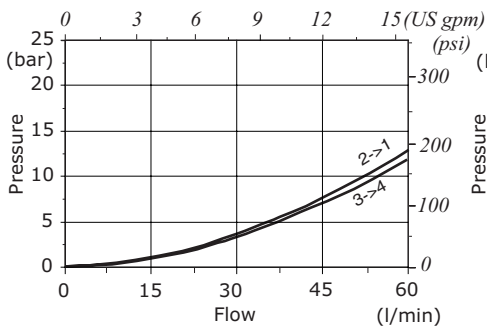

ER12M performance limit

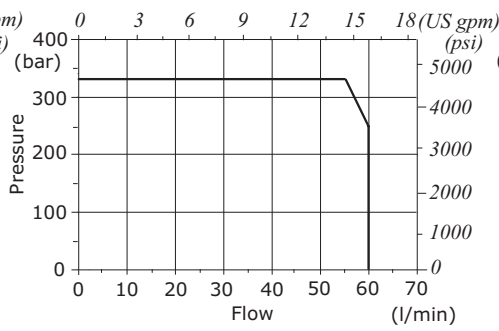

ER12M pressure drop vs. flow
- Spool 8 -

