



PP..X type flow control pressure compensated valves - 3 way

- Solenoid proportional type
- With exceeding flow to pressure
- From SAE08 to SAE16 cavities

Technical specifications and diagrams are measured with mineral oil of 46 cSt viscosity at 40°C (104°F) temperature.

	PP08X	PP10X	PP12X	PP16X	
Nominal flow	Q1max= 20 l/min (5.2 US gpm) Q3max= 15 l/min (3.9 US gpm)	50 l/min (13.2 US gpm) 30 l/min (8 US gpm)	90 l/min (23.8 US gpm) 60 l/min (16 US gpm)	150 l/min (39.6 US gpm) 90 l/min (23.8 US gpm)	
Max. pressure	315 bar (4560 psi)				
Oil leakage	at 210 bar (3050 psi)	80 cm ³ /min (4.9 in ³ /min)	150 cm ³ /min (9.2 in ³ /min)	250 cm ³ /min (15.3 in ³ /min)	400 cm ³ /min (24.4 in ³ /min)
Fluid	mineral based oil				
Viscosity	10-200 cSt				
Max level of contamination	18/16/13 ISO4406				
Fluid temperature	with NBR seals with FPM seals	from -20°C (-4°F) to 80°C (176°F) from -20°C (-4°F) to 100°C (212°F)			
Environmental temp. for working conditions	from -20°C (-4°F) to 50°C (122°F)				
Cavity	SAE 08/3	SAE 10/3	SAE 12/3	SAE 16/3	
Coil type*	BQP19 or BH				
Nominal voltages	12 VDC - 24 VDC ± 10%				
Power rating	20.4 W (BH) - 15 W (BQP19)				
Max control current	12 V -> 1.70 A - 24 V -> 0.85 A (BH) 12 V -> 1.25 A - 24 V -> 0.63 A (BQP19)				
Dither frequency	150 Hz				
Hysteresis	8%				
Weight	0.44 kg (0.97 lb)	0.49 kg (1.08 lb)	0.61 kg (1.34 lb)	1 kg (2.20 lb)	

NOTE - For different conditions, please contact Walvoil Sales Dpt. - For coils further features see from page 206.

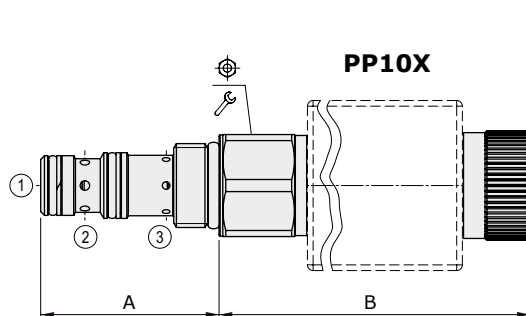
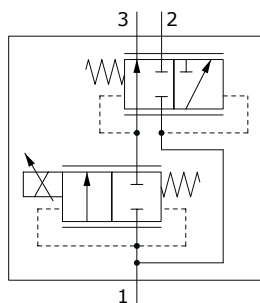

Valve type	A		B		Nm	lbft
	mm	in	mm	in		
PP08X/A0N	40.8	1.60	94	3.70	24	30
PP10X/A0N	47.2	1.86	96.4	3.79	27	50
PP12X/A0N	73.5	2.89	97.4	3.83	32	75
PP16X/A0N	75.1	2.95	121.4	4.78	41	95

For dimensions with different type of emergency see page 213

Ordering codes and description composition

PP08X/A0NB

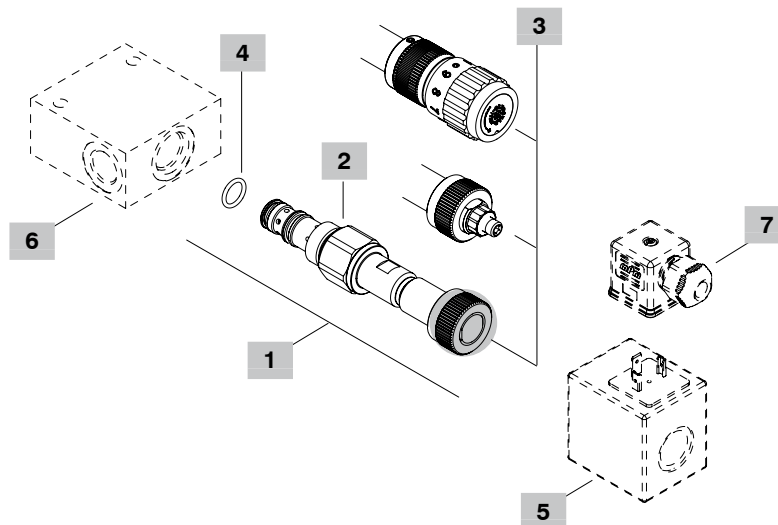
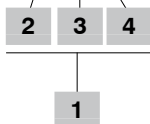

1 Cartridges

TYPE	CODE	DESCRIPTION
SAE cavity 08/3		
PP08X/A0NB	0PP08002014	Without emergency
PP08X/A0TB	0PP08002015	Screw type emergency
PP08X/A0VB	0PP08002016	Handknob emergency
SAE cavity 10/3		
PP10X/A0NB	0PP10002031	Without emergency
PP10X/A0TB	0PP10002033	Screw type emergency
PP10X/A0VB	0PP10002035	Handknob emergency
SAE cavity 12/3		
PP12X/A0NB	0PP12002037	Without emergency
PP12X/A0TB	0PP12002039	Screw type emergency
PP12X/A0VB	0PP12002041	Handknob emergency
SAE cavity 16/3		
PP16X/A0NB	0PP16002013	Without emergency
PP16X/A0TB	0PP16002015	Screw type emergency
PP16X/A0VB	0PP16002014	Handknob emergency

2 Pressure drop from 1 to 3

TYPE	DESCRIPTION
A	12 bar (170 psi)

3 Emergency

TYPE	DESCRIPTION
N	Without emergency
T	Screw type
V	Handknob

4 Seals

TYPE	DESCRIPTION
B	NBR (Buna) Std configuration without addition
V	For valve with FPM (Viton) o-ring seals, contact Sales Dept.

5 Coils

TYPE	CODE	DESCRIPTION
BQP19 12VDC	4SL5000126	12VDC-ISO4400 coil
BH 12VDC	4SLD001200	12VDC-ISO4400 coil

For complete coils list see from page 206

6 Valve body

TYPE	CODE	DESCRIPTION
SAE 08/3-SAE8	3CC0830K11	Aluminium body for cavity 08 valve, SAE8 std thread
SAE 10/3-SAE8	3CC1030K11	Aluminium body for cavity 10 valve, SAE8 std thread
SAE 12/3-SAE10	3CC1230L11	Aluminium body for cavity 12 valve, SAE10 std thread
SAE 16/3-SAE12	3CC1630M11	Aluminium body for cavity 16 valve, SAE12 std thread

Note: aluminium body can stand up to 210 bar (3050 psi)
For steel bodies or different threading see from page 217

7 Connector

TYPE	CODE	DESCRIPTION
ISO4400	4CN1009995	Connector

For complete connectors list see from page 206

Rating diagrams

PP08X
flow regulating vs. % max. control current
 Q_{in} = priority flow + 30%

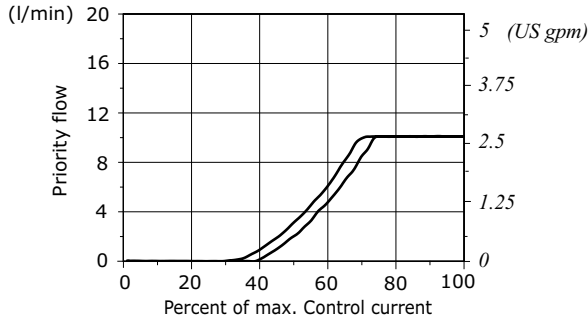

PP08X
pressure compensation diagram 2→3
 for % of control current

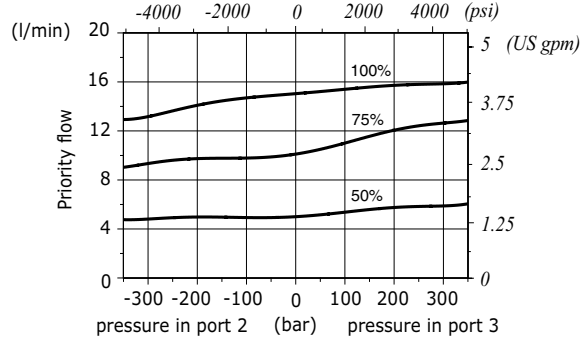

PP08X
pressure drop with de-energized coil
 from 1→2

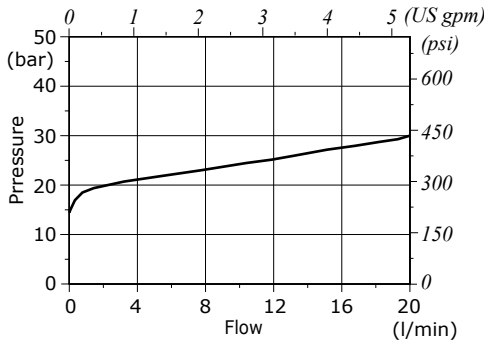

PP10X
flow regulating vs. % max. control current
 Q_{in} = priority flow + 5%

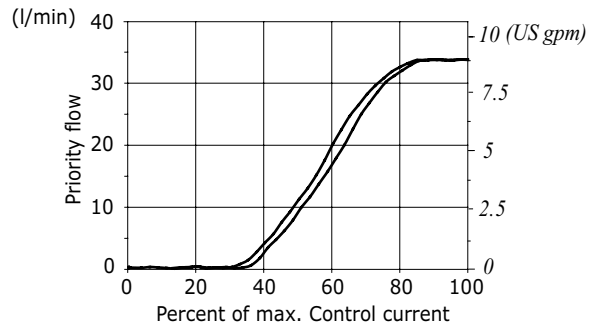

PP10X
pressure compensation diagram 2→3
 for % of control current

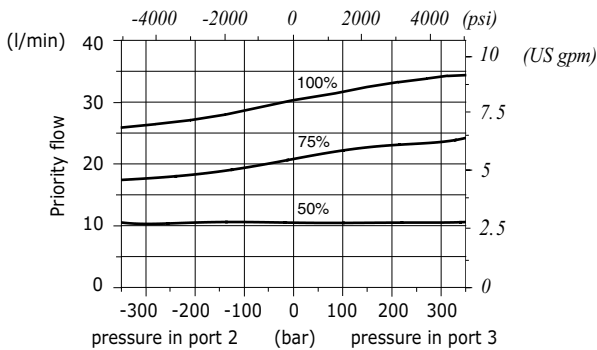

PP10X
pressure drop with de-energized coil
 from 1→2

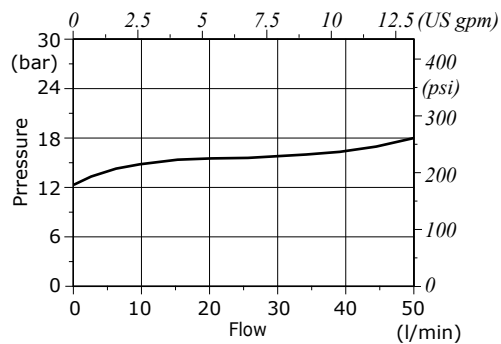

Rating diagrams

PP12X
flow regulating vs. % max. control current
 $Q_{in} = \text{priority flow} + 15\%$

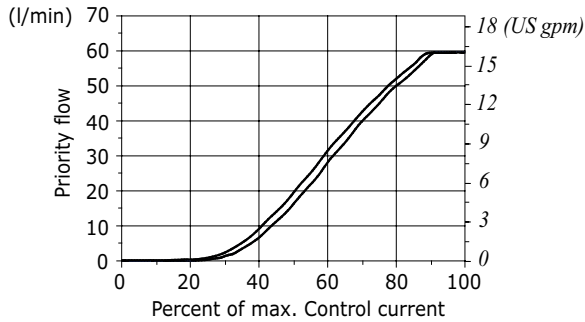

PP12X
pressure compensation diagram 2→3
for % of control current

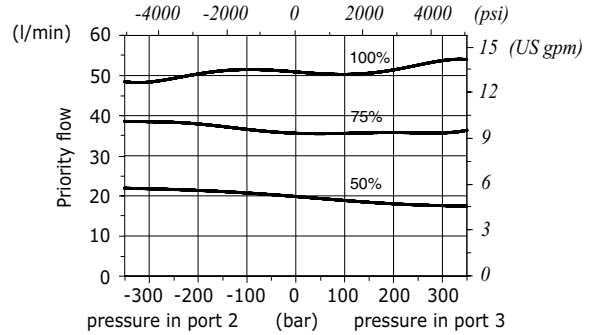

PP12X
pessure drop with de-energized coil
from 1->2

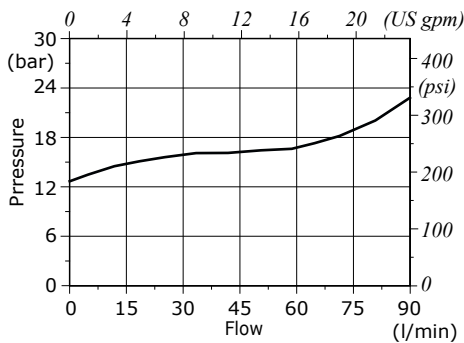

PP16X
flow regulating vs. % max. control current
 $Q_{in} = \text{priority flow} + 10\%$

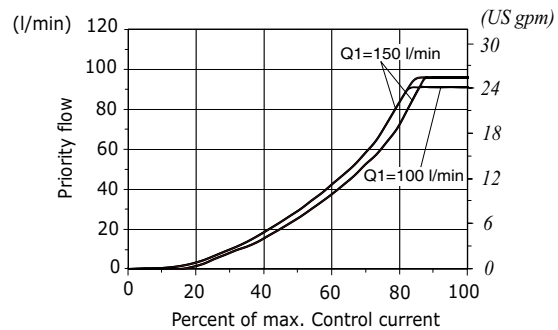

PP16X
pressure compensation diagram 2→3
for % of control current - $Q_1=100 \text{ l/min}$

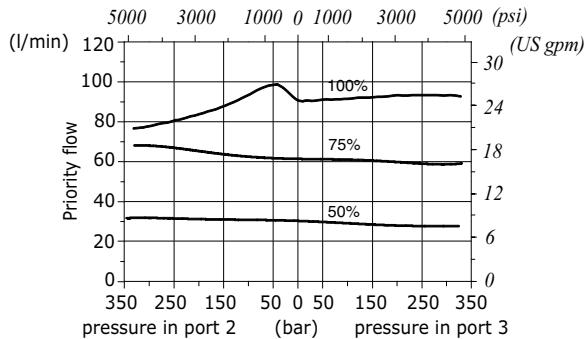

PP16X
pessure drop with de-energized coil
from 1->2

